

Opening Date: 2020-08-13   
Closing Date: 2020-08-24   
Closing Time: 11:00

## INSTITUTION DETAILS

Institution Name: King Edward VIII hospital   
Province: KwaZulu-Natal  
Department or Entity: Department of Health  
Division or section: Central Supply Chain Management  
Place where goods / services is required: KING EDWARD VIII HOSPITAL FLUE CLINIC  
Date Submitted: 2020-08-11 



## ITEM CATEGORY AND DETAILS

Quotation Number: ZNQ:  
KEH 197  
Item Category: Services   
Item Description: FLUE CLINIC MAINTENANCE AND REPAIRS

**\* QUOTATION IS ATTACHED TO ADVERT PLEASE PRINT AND BRING IT WITH YOU FOR SITE MEETING, YOU WILL NOT BE ALLOWED TO PARTICIPATE IF YOU DO NOT HAVE THE COPY WITH YOU, ALL COPIES MUST BE STAMPED AFTER BRIEFING SESSION, ALL QUOTATIONS SHOULD BE DROPPED OF AT THE HOSPITAL TENDOR BOX IN A SEALED ENVELOPE, NO EMAILS WILL BE ALLOWED. PLEASE WEAR YOUR PPE GEAR AND BRING YOUR OWN PEN.**

Quantity (if supplies)

## COMPULSORY BRIEFING SESSION / SITE VISIT

Select Type: Compulsory Briefing Session   
Date: 2020-08-18   
Time: 11H00  
Venue: KING EDWARD VIII HOSPITAL OUTSIDE MAINTENENCE DEPT

QUOTES CAN BE COLLECTED FROM: IS ATTACHED TO ADVERT

QUOTES SHOULD BE DELIVERED TO: KING EDWARD VIII HOSPITAL TENDOR BOX

## ENQUIRIES REGARDING THE ADVERT MAY BE DIRECTED TO:

Name: KHULANI MTHEMBU  
Email: khulani.mthembu@kznhealth.gov.za  
Contact Number: 031 360 3446  
Finance Manager Name: MRS G. ANDERSON  
Finance Manager Signature: 

No late quotes will be considered

# END USER SPECIFICATION FORM

Quote Number: \_\_\_\_\_

Item Description: FLU CLINIC MAINTENANCE AND REPAIRS

Department/Section: MAINTENANCE Purpose of Item: RENOVATION

**1. Pre-qualification criteria if any:**

1.1. Is the item required to have a regulatory body certification (e.g. SABS, SANS, SANAS, ISO, CIDB, etc.)? Yes / No:

Regulatory Body / certification required if Yes: SO, GB LEVEL 3

1.2. Is a compulsory site inspection / briefing session required? Yes / ~~No~~

if Yes, specify: Date 1/1/2020 Time \_\_\_\_\_ Place KING EDWARD VII HOSPITAL

1.3. Is local production and content part of the quote? Yes / No

if Yes, specify: NO

1.4. Provisions of section 4(1)(a) of the PPPFA Regulations, 2017 if applicable? Yes / No

if Yes, specify: NO

1.5. Liability Cover insurance? Yes / ~~No~~

if Yes, specify: NO

**2. What is the specification of the required item?**

List specifications to be advertised	Comment
1. <u>FLU CLINIC MAINTENANCE AND REPAIRS</u>	
2. _____	
3. <u>PLEASE SEE THE ATTACHED SPECIFICATION</u>	
4. _____	
5. _____	

**3. Does a sample need to be submitted? Yes / No (select option 3.1 or 3.2)**

3.1. Deadline for submission if Yes: Date \_\_\_\_\_ Time \_\_\_\_\_ Place \_\_\_\_\_

or

3.2. Specify that samples must be made available when requested in writing. Yes  or No

**4. Penalties to be noted by the suppliers:**

4.1. If the supplier fails to deliver any or all of the goods or to perform the services within the period(s) specified in the contract, the purchaser shall, without prejudice to its other remedies under the contract, deduct from the contract price, as a penalty, a sum calculated on the delivered price of the delayed goods or unperformed services using the current prime interest rate calculated for each day of the delay until actual delivery or performance.

**5. What is the evaluation criteria / special terms and conditions to be advertised?**

List evaluation criteria / special terms and conditions to be advertised (if applicable)	
1. Pre-qualification criteria	Does the offer meet the pre-qualification criteria?
2. Administrative	Does the offer comply to stipulated administrative requirements?
3. Conformance:	Was the product made or service performed to specifications?
4. Performance:	Will/does the product/service fulfil its performance obligation, in a manner that releases the supplier from all liabilities under the contract?
5. Features:	What characteristics does the product or service have?
6. Reliability:	How long can a product go between failures and the need for maintenance? (guarantee)
7. Durability:	What is the useful life for the product? How will the product hold up under extended use?
8. Serviceability:	How easy is it to repair, maintain or support the product or service? (customer support)
9. Ability & Capacity	The ability and capacity of the vendor to execute the contract
10. Preference points	Preferential Procurement System (80/20) if applicable

Name of End-user (in full)	<u>G.S. DLADLA</u>	Name of SCM Rep (in full)	
Designation / Rank (in full)	<u>MAINTENANCE MANAGER</u>	Designation / Rank (in full)	
Signature		Signature	
Date	<u>29/07/2020</u>	Date	





**DECLARATION OF INTEREST**

1. Any legal person, including persons employed by the state<sup>1</sup>, or persons having a kinship with persons employed by the state, including a blood relationship, may make an offer or offers in terms of this invitation to quote (includes a price quotation, advertised competitive quote, limited quote or proposal). In view of possible allegations of favouritism, should the resulting quote, or part thereof, be awarded to persons employed by the state, or to persons connected with or related to them, it is required that the bidder or his/her authorised representative declare his/her position in relation to the evaluating/adjudicating authority where-
  - the bidder is employed by the state; and/or
  - the legal person on whose behalf the bidding document is signed, has a relationship with persons/a person who are/is involved in the evaluation and or adjudication of the quote(s), or where it is known that such a relationship exists between the person or persons for or on whose behalf the declarant acts and persons who are involved with the evaluation and or adjudication of the quote.
2. In order to give effect to the above, the following questionnaire must be completed and submitted with the quote.

- |  |   |
|--|---|
| 2.1. Full Name of bidder/representative.....   | 2.4. Company Registration Number: ..... |
| 2.2. Identity Number: .....  | 2.5. Tax Reference Number: .....        |
| 2.3. Position occupied in the Company (director, trustee, shareholder <sup>2</sup> ):..... | 2.6. VAT Registration Number: .....     |

2.7. The names of all directors / trustees / shareholders / members, their individual identity numbers, tax reference numbers and, if applicable, employee / persal numbers must be indicated in paragraph 3 below. [TICK APPLICABLE]

2.8. Are you or any person connected with the bidder presently employed by the state? YES NO

2.8.1. If so, furnish the following particulars:  
 Name of person / director / trustee / shareholder/ member: .....  
 Name of state institution at which you or the person connected to the bidder is employed:.....  
 Position occupied in the state institution: ..... Any other particulars:.....

2.8.2. If you are presently employed by the state, did you obtain the appropriate authority to undertake remunerative work outside employment in the public sector? YES NO

2.8.2.1. If yes, did you attach proof of such authority to the quote document?

*(Note: Failure to submit proof of such authority, where applicable, may result in the disqualification of the quote.)*

2.8.2.2. If no, furnish reasons for non-submission of such proof: .....

2.9. Did you or your spouse, or any of the company's directors / trustees / shareholders / members or their spouses conduct business with the state in the previous twelve months? YES NO

2.9.1. If so, furnish particulars:.....

2.10. Do you, or any person connected with the bidder, have any relationship (family, friend, other) with a person employed by the state and who may be involved with the evaluation and or adjudication of this quote? YES NO

2.10.1. If so, furnish particulars:.....

2.11. Are you, or any person connected with the bidder, aware of any relationship (family, friend, other) between any other bidder and any person employed by the state who may be involved with the evaluation and or adjudication of this quote? YES NO

2.11.1. If so, furnish particulars:.....

2.12. Do you or any of the directors / trustees / shareholders / members of the company have any interest in any other related companies whether or not they are bidding for this contract? YES NO

2.12.1. If so, furnish particulars:.....

**3. Full details of directors / trustees / members / shareholders.**

NB: The Department Of Health will validate **details of directors / trustees / members / shareholders** on CSD. It is the suppliers' responsibility to ensure that their details are up-to-date and verified on CSD. If the Department cannot validate the **information** on CSD, the quote will not be considered and passed over as non-compliant according to National Treasury Instruction Note 4 (a) 2016/17.

**4 DECLARATION**

I, THE UNDERSIGNED (NAME).....CERTIFY THAT THE INFORMATION FURNISHED IN PARAGRAPHS 2.

I ACCEPT THAT THE STATE MAY REJECT THE QUOTE OR ACT AGAINST ME SHOULD THIS DECLARATION PROVE TO BE FALSE.

.....	.....	.....	.....
Name of bidder	Signature	Position	Date

\*State\* means –

- |   |   |
|---|---|
| a) any national or provincial department, national or provincial public entity or constitutional institution within the meaning of the Public Finance Management Act, 1999 (Act No. 1 of 1999); | c) provincial legislature;                                    |
| b) any municipality or municipal entity;  | d) national Assembly or the national Council of provinces; or |
|   | e) Parliament.  |

\*Shareholder\* means a person who owns shares in the company and is actively involved in the management of the enterprise or business and exercises control over the enterprise.

## SPECIAL CONTRACT CONDITIONS OF QUOTATIONS

### 1. AMENDMENT OF CONTRACT

- 1.1. Any amendment to or renunciation of the provisions of the contract shall at all times be done in writing and shall be signed by both parties.

### 2. CHANGE OF ADDRESS

- 2.1. Bidders must advise the Department of Health (institution where the offer was submitted) should their address (*domicilium citandi et executandi*) details change from the time of bidding to the expiry of the contract.

### 3. GENERAL CONDITIONS ATTACHED TO THIS QUOTATION

- 3.1. The institution is under no obligation to accept the lowest or any quote.
- 3.2. The price quoted must include VAT (if VAT vendor). However, it must be noted that the department reserves the right to evaluate all quotations excluding VAT as some bidders may not be VAT vendors.
- 3.3. The bidder must ensure the correctness & validity of quote:
- (i) *that the price(s), rate(s) & preference quoted cover all for the work/item (s) & accept that any mistakes regarding the price (s) & calculations will be at the bidder's risk*
- 3.4. The bidder must accept full responsibility for the proper execution & fulfilment of all obligations conditions devolving on under this agreement, as the Principal (s) liable for the due fulfilment of this contract.
- 3.5. This quotation will be evaluated based on the 80/20 points system, specification & correctness of information. All required documentation must be completed in full and submitted.
- 3.6. Offers must comply strictly with the specification.
- 3.7. Only offers that meet or are greater than the specification will be considered.
- 3.8. Late quotes will not be considered.
- 3.9. Expired product/s will not be accepted. All products supplied must be valid for a minimum period of six months.
- 3.10. A bidder not registered on the Central Suppliers Database or verification has failed will not be considered.
- 3.11. All delivery costs must be included in the quote price, for delivery at the prescribed destination.
- 3.12. Only firm prices will be accepted. Such prices must remain firm for the contract period. Non-firm prices (including rates of exchange variations) will not be considered.
- 3.13. In cases where different delivery points influence the pricing, a separate pricing schedule must be submitted for each delivery point.
- 3.14. In the event of a bidder having multiple quotes, only the cheapest according to specification will be considered. Furthermore a verification will be done to identify if bidders have multiple companies and are quoting (cover-quoting) for this bid. In such instances only the cheapest bid according to specification will be considered.

### 4. SPECIAL INSTRUCTIONS AND NOTICES TO BIDDERS REGARDING THE COMPLETION OF THIS QUOTATION.

- 4.1. Unless inconsistent with or expressly indicated otherwise by the context, the singular shall include the plural and vice versa and with words importing the masculine gender shall include the feminine and the neuter.
- 4.2. Under no circumstances whatsoever may the quotation/bid forms be retyped or redrafted. Photocopies of the original bid documentation may be used, but an original signature must appear on such photocopies.
- 4.3. The bidder is advised to check the number of pages and to satisfy himself that none are missing or duplicated.
- 4.4. Quotation submitted must be complete in all respects.
- 4.5. Any alteration made by the bidder must be initialled.
- 4.6. Use of correcting fluid is prohibited
- 4.7. Quotation will be opened in public as soon as practicable after the closing time of quotation.
- 4.8. Where practical, prices are made public at the time of opening quotations.
- 4.9. If it is desired to make more than one offer against any individual item, such offers should be given on a photocopy of the page in question. Clear indication thereof must be stated on the schedules attached.

### 5. SPECIAL INSTRUCTIONS REGARDING HAND DELIVERED QUOTATIONS

- 5.1. Quotation shall be lodged at the address indicated not later than the closing time specified for their receipt, and in accordance with the directives in the quotation documents.
- 5.2. Each quotation shall be addressed in accordance with the directives in the quotation documents and shall be lodged in a separate sealed envelope, with the name and address of the bidder, the quotation number and closing date indicated on the envelope. The envelope shall not contain documents relating to any quotation other than that shown on the envelope. If this provision is not complied with, such quotations/bids may be rejected as being invalid.
- 5.3. All quotations received in sealed envelopes with the relevant quotation numbers on the envelopes are kept unopened in safe custody until the closing time of the quotation/bids. Where, however, a quotation is received open, it shall be sealed. If it is received without a quotation/bid number on the envelope, it shall be opened, the quotation number ascertained, the envelope sealed and the quotation number written on the envelope.
- 5.4. A specific box is provided for the receipt of quotations, and no quotation found in any other box or elsewhere subsequent to the closing date and time of quotation will be considered.



- 5.5. No quotation/bid sent through the post will be considered if it is received after the closing date and time stipulated in the quotation documentation, and proof of posting will not be accepted as proof of delivery.
- 5.6. Quotation documents must not be included in packages containing samples. Such quotations may be rejected as being invalid.

**6. SAMPLES**

- 6.1. In the case of the quote document stipulating that samples are required, the supplier will be informed in due course when samples should be provided to the institution. (This decreases the time of safety and storage risk that may be incurred by the respective institution). The bidders sample will be retained if such bidder wins the contract.
  - (i) If a company/s who has not won the quote requires their samples, they must advise the institution in writing of such.
  - (ii) If samples are not collected within three months of close of quote the institution reserves the right to dispose of them at their discretion.
- 6.2. **Samples must be made available when requested in writing or if stipulated on the document.**
  - (i) If a Bidder fails to provide a sample of their product on offer for scrutiny against the set specification when requested, their offer will be rejected. All testing will be for the account of the bidder.

**7. COMPULSORY SITE INSPECTION / BRIEFING SESSION**

7.1. Bidders who fail to attend the compulsory meeting will be disqualified from the evaluation process.

- (i) The institution has determined that a compulsory site meeting  take place
- (ii) Date / /  Time :  Place

Institution Stamp:	Institution Site Inspection / briefing session Official  Full Name: .....  Signature: .....  Date: .....
--------------------	--

**8. STATEMENT OF SUPPLIES AND SERVICES**

8.1. The contractor shall, when requested to do so, furnish particulars of supplies delivered or services executed. If he/she fails to do so, the Department may, without prejudice to any other rights which it may have, institute inquiries at the expense of the contractor to obtain the required particulars.

**9. SUBMISSION AND COMPLETION OF SBD 6.1**

9.1. Should a bidder wish to qualify for preference points they must complete a SBD 6.1 document. Failure by a bidder to provide all relevant information required, will result in such a bidder not being considered for preference point's allocation. The preferences applicable on the closing date will be utilized. Any changes after the closing date will not be considered for that particular quote.

**10. TAX COMPLIANCE REQUIREMENTS**

- 10.1. In the event that the tax compliance status has failed on CSD, **it is the suppliers' responsibility to provide a SARS pin in order for the institution to validate the tax compliance status of the supplier.**
- 10.2. In the event that the institution cannot validate the suppliers' tax clearance on SARS as well as the Central Suppliers Database, **the quote will not be considered and passed over as non-compliant according to National Treasury Instruction Note 4 (a) 2016/17.**

**11. TAX INVOICE**

11.1. A tax invoice shall be in the currency of the Republic of South Africa and shall contain the following particulars:

- (i) the name, address and registration number of the supplier;
- (ii) the name and address of the recipient;
- (iii) an individual serialized number and the date upon which the tax invoice is issued;
- (iv) a description and quantity or volume of the goods or services supplied;
- (v) the official department order number issued to the supplier;
- (vi) the value of the supply, the amount of tax charged;
- (vii) the words tax invoice in a prominent place.

**12. PATENT RIGHTS**

The supplier shall indemnify the **KZN Department of Health** (here after known as the purchaser) against all third-party claims of infringement of patent, trademark, or industrial design rights arising from use of the goods or any part thereof by the purchaser.

### **13. PENALTIES**

- 13.1. If at any time during the contract period, the service provider is unable to perform in a timely manner, the service provider must notify the institution in writing/email of the cause of and the duration of the delay. Upon receipt of the notification, the institution should evaluate the circumstances and, if deemed necessary, the institution may extend the service provider's time for performance.
- 13.2. In the event of delayed performance that extends beyond the delivery period, the institution is entitled to purchase commodities of a similar quantity and quality as a substitution for the outstanding commodities, without terminating the contract, as well as return commodities delivered at a later stage at the service provider's expense.
- 13.3. Alternatively, the institution may elect to terminate the contract and procure the necessary commodities in order to complete the contract. In the event that the contract is terminated the institution may claim damages from the service provider in the form of a penalty. The service provider's performance should be captured on the service provider database in order to determine whether or not the service provider should be awarded any contracts in the future.
- 13.4. If the supplier fails to deliver any or all of the goods or to perform the services within the period(s) specified in the contract, the purchaser shall, without prejudice to its other remedies under the contract, deduct from the contract price, as a penalty, a sum calculated on the delivered price of the delayed goods or unperformed services using the current prime interest rate calculated for each day of the delay until actual delivery or performance.

### **14. TERMINATION FOR DEFAULT**

- 14.1. The purchaser, without prejudice to any other remedy for breach of contract, by written notice of default sent to the supplier, may terminate this contract in whole or in part:
  - (i) if the supplier fails to deliver any or all of the goods within the period(s) specified in the contract,
  - (ii) if the supplier fails to perform any other obligation(s) under the contract; or
  - (iii) if the supplier, in the judgment of the purchaser, has engaged in corrupt or fraudulent practices in competing for or in executing the contract.
- 14.2. In the event the purchaser terminates the contract in whole or in part, the purchaser may procure, upon such terms and in such manner as it deems appropriate, goods, works or services similar to those undelivered, and the supplier shall be liable to the purchaser for any excess costs for such similar goods, works or services.
- 14.3. Where the purchaser terminates the contract in whole or in part, the purchaser may decide to impose a restriction penalty on the supplier by prohibiting such supplier from doing business with the public sector for a period not exceeding 10 years.

### **15. FAILURE TO COMPLY WITH ABOVE WILL RESULT IN YOUR QUOTE BEING PASSED OVER.**



**PREFERENCE POINTS CLAIM FORM IN TERMS OF THE PREFERENTIAL PROCUREMENT REGULATIONS 2017**

This preference form must form part of all quotes invited. It contains general information and serves as a claim form for preference points for Broad-Based Black Economic Empowerment (B-BBEE) Status Level of Contribution

**NB: BEFORE COMPLETING THIS FORM, BIDDERS MUST STUDY THE GENERAL CONDITIONS, DEFINITIONS AND DIRECTIVES APPLICABLE IN RESPECT OF B-BBEE, AS PRESCRIBED IN THE PREFERENTIAL PROCUREMENT REGULATIONS, 2017.**

**1. GENERAL CONDITIONS**

1.1 The following preference point systems are applicable to all quotes:

- the 80/20 system for requirements with a Rand value of up to R50 000 000 (all applicable taxes included); and

1.2 The value of this quote is estimated to not exceed R50 000 000 (all applicable taxes included) and therefore the 80/20 preference point system shall be applicable.

1.3 Points for this quote shall be awarded for:

- (a) Price; and
- (b) B-BBEE Status Level of Contributor.

1.4 The maximum points for this quote is allocated as follows:

	POINTS
<b>PRICE</b>	80
<b>B-BBEE STATUS LEVEL OF CONTRIBUTOR</b>	20
<b>Total points for Price and B-BBEE must not exceed</b>	100

1.5 Failure on the part of a bidder to submit proof of B-BBEE Status level of contributor together with the quote, will be interpreted to mean that preference points for B-BBEE status level of contribution are not claimed.

1.6 The purchaser reserves the right to require of a bidder, either before a quote is adjudicated or at any time subsequently, to substantiate any claim in regard to preferences, in any manner required by the purchaser.

**2. DEFINITIONS**

- (a) **"B-BBEE"** means broad-based black economic empowerment as defined in section 1 of the Broad-Based Black Economic Empowerment Act;
- (b) **"B-BBEE status level of contributor"** means the B-BBEE status of an entity in terms of a code of good practice on black economic empowerment, issued in terms of section 9(1) of the Broad-Based Black Economic Empowerment Act;
- (c) **"bid"** means a written offer in a prescribed or stipulated form in response to an invitation by an organ of state for the provision of goods or services, through price quotations, advertised competitive bidding processes or proposals;
- (d) **"Broad-Based Black Economic Empowerment Act"** means the Broad-Based Black Economic Empowerment Act, 2003 (Act No. 53 of 2003);
- (e) **"EME"** means an Exempted Micro Enterprise in terms of a code of good practice on black economic empowerment issued in terms of section 9 (1) of the Broad-Based Black Economic Empowerment Act;
- (f) **"functionality"** means the ability of a tenderer to provide goods or services in accordance with specifications as set out in the tender documents.
- (g) **"prices"** includes all applicable taxes less all unconditional discounts;
- (h) **"proof of B-BBEE status level of contributor"** means:
  - 1) B-BBEE Status level certificate issued by an authorized body or person;
  - 2) A sworn affidavit as prescribed by the B-BBEE Codes of Good Practice;
  - 3) Any other requirement prescribed in terms of the B-BBEE Act;
- (i) **"QSE"** means a qualifying small business enterprise in terms of a code of good practice on black economic empowerment issued in terms of section 9 (1) of the Broad-Based Black Economic Empowerment Act;
- (j) **"rand value"** means the total estimated value of a contract in Rand, calculated at the time of bid invitation, and includes all applicable taxes;

**3. POINTS AWARDED FOR PRICE**

**3.1 THE 80/20 PREFERENCE POINT SYSTEMS**

A maximum of 80 points is allocated for price on the following basis:

$$Ps = 80 \left( 1 - \frac{Pt - P \text{ min}}{P \text{ min}} \right) \text{ Where}$$

- Ps = Points scored for price of bid under consideration
- Pt = Price of bid under consideration
- Pmin = Price of lowest acceptable bid

**4. POINTS AWARDED FOR B-BBEE STATUS LEVEL OF CONTRIBUTOR**

4.1 In terms of Regulation 6 (2) and 7 (2) of the Preferential Procurement Regulations, preference points must be awarded to a bidder for attaining the B-BBEE status level of contribution in accordance with the table below:

B-BBEE Status Level of Contributor	Number of points (80/20 system)
1	20
2	18
3	14
4	12
5	8
6	6
7	4
8	2
Non-compliant contributor	0

**5. BID DECLARATION**

5.1 Bidders who claim points in respect of B-BBEE Status Level of Contribution must complete the following:

**6. B-BBEE STATUS LEVEL OF CONTRIBUTOR CLAIMED IN TERMS OF PARAGRAPHS 1.4 AND 4.1**

6.1 B-BBEE Status Level of Contributor: = .....(maximum of 20 points)

(Points claimed in respect of paragraph 7.1 must be in accordance with the table reflected in paragraph 4.1 and must be substantiated by relevant proof of B-BBEE status level of contributor.

**7. SUB-CONTRACTING**

(Tick applicable box)

7.1 Will any portion of the contract be sub-contracted?

YES	<input type="checkbox"/>	NO	<input type="checkbox"/>
-----	--------------------------	----	--------------------------

7.1.1 If yes, indicate:

- i) What percentage of the contract will be subcontracted.....%
- ii) The name of the sub-contractor.....
- iii) The B-BBEE status level of the sub-contractor.....

8. Whether the sub-contractor is an EME or QSE

(Tick applicable box)

iv) Specify, by ticking the appropriate box, if subcontracting with an enterprise in terms of Preferential Procurement Regulations 2017:

YES	<input type="checkbox"/>	NO	<input type="checkbox"/>
-----	--------------------------	----	--------------------------

Designated Group: An EME or QSE which is at least 51% owned by:	EME √	QSE √
Black people		
Black people who are youth		
Black people who are women		
Black people with disabilities		
Black people living in rural or underdeveloped areas or townships		
Cooperative owned by black people		
Black people who are military veterans		
OR		
Any EME		
Any QSE		

9. **DECLARATION WITH REGARD TO COMPANY/FIRM**

9.1 Name of company/firm:.....

9.2 VAT registration number:.....

9.3 Company registration number:.....

9.4 TYPE OF COMPANY/ FIRM [TICK APPLICABLE BOX]

- Partnership/Joint Venture / Consortium
- One person business/sole propriety
- Close corporation
- Company
- (Pty) Limited

9.5 DESCRIBE PRINCIPAL BUSINESS ACTIVITIES

.....  
.....

9.6 COMPANY CLASSIFICATION [TICK APPLICABLE BOX]

- Manufacturer
- Supplier
- Professional service provider
- Other service providers, e.g. transporter, etc.

9.7 Total number of years the company/firm has been in business:.....

9.8 I/we, the undersigned, who is / are duly authorised to do so on behalf of the company/firm, certify that the points claimed, based on the B-BBE status level of contributor indicated in paragraphs 1.4 and 6.1 of the foregoing certificate, qualifies the company/ firm for the preference(s) shown and I / we acknowledge that:

- i) The information furnished is true and correct;
- ii) The preference points claimed are in accordance with the General Conditions as indicated in paragraph 1 of this form;
- iii) In the event of a contract being awarded as a result of points claimed as shown in paragraphs 1.4 and 6.1, the contractor may be required to furnish documentary proof to the satisfaction of the purchaser that the claims are correct;
- iv) If the B-BBEE status level of contributor has been claimed or obtained on a fraudulent basis or any of the conditions of contract have not been fulfilled, the purchaser may, in addition to any other remedy it may have –
  - (a) disqualify the person from the bidding process;
  - (b) recover costs, losses or damages it has incurred or suffered as a result of that person's conduct;
  - (c) cancel the contract and claim any damages which it has suffered as a result of having to make less favourable arrangements due to such cancellation;
  - (d) recommend that the bidder or contractor, its shareholders and directors, or only the shareholders and directors who acted on a fraudulent basis, be restricted by the National Treasury from obtaining business from any organ of state for a period not exceeding 10 years, after the *audi alteram partem* (hear the other side) rule has been applied; and
  - (e) forward the matter for criminal prosecution.

<p><b>WITNESSES</b></p> <p>1. ....</p> <p>2. ....</p>
---

<p>.....</p> <p><b>SIGNATURE(S) OF BIDDERS(S)</b></p> <p>DATE: .....</p> <p>ADDRESS.....</p> <p>.....</p> <p>.....</p>
--



PROVINCE OF KWAZULU-NATAL  
DEPARTMENT OF HEALTH

Flu clinic maintenance and repairs

ZNQ NO: KEH 197

Closing Date & Time : @ 11h00  
Contract Period : 03Weeks  
Validity Period : 60 Days  
Technical Contact Person : MR. MMM Mngomezulu  
Contact Telephone Number : 031 360 3716  
On Site Inspection :

DOCUMENTS DELIVERED BY HAND MUST BE DEPOSITED IN THE QUOTATION BOX SITUATED IN:

THE TENDER-BOX  
KING EDWARD 8 HOPITAL  
P/BAG

THE QUOTATION BOX IS AVAILABLE ON THE FOLLOWING DAYS AND TIMES: MONDAYS TO FRIDAYS 07h30 – 16h00

DOCUMENTS POSTED SHALL BE ADDRESSED TO:

SUPPLY CHAIN MANAGEMENT:  
KING EDWARD 8 HOPITAL  
P/BAG

N.B.: THE QUOTATION BOX WILL BE CLEARED AT 11:00Hrs ON THE DUE DATE.

Name of Tenderer \_\_\_\_\_

PROVINCE OF KWAZULU-NATAL  
DEPARTMENT OF HEALTH

**Flu clinic maintenance and repairs**

ZNO NO: KEH 197

PROJECT SPECIFICATIONS

**1. NOTES TO TENDERERS**

**1.1. SCOPE OF CONTRACT**

This Contract is for the complete execution of the project indicated above.

**1.2. CONDITIONS OF CONTRACT AND PRELIMINARIES**

**1.2.1 PERIOD OF CONTRACT**

**03 Weeks** as the Contract Period for the completion of *all Works* from date of Site handover.

**1.2.2 CONTRACT GUARANTEE:**

The successful Tenderer will **NOT** be required to submit a contract guarantee.

**1.2.3 GUARANTEE PERIOD**

The guarantee period for *all Works* and all materials must be for a minimum of **One (1) Year** from the date of first delivery.

**1.2.4 SITE AND MODE OF PROCEDURE**

The work contained in this contract will be carried out on the site of the existing Institution.

The Contractor is advised that the existing premises will be occupied throughout the period of the contract.

Damage to existing buildings - Tenderers to note that any damages done or occurring to any of the buildings will be repaired at the expense of the contractor/ Tenderer.

The repairs must be to the satisfaction of the KwaZulu- Natal Department of Health.

1.2.5 **SATISFACTORY INSTALLATION**

The whole of the installation shall be carried out in accordance with the South African Bureau of Standards Code of Practice for the application of National Building Regulations, the KZNPA Standard Preambles to all Trades, the KZNPA General Electrical Specification, the South African Bureau of Standards Code of Practice for the Wiring of Premises 0142-1 and the Occupational Health and Safety Act 85 of 1993 as amended.

**Copies of the KZNPA Standard Preambles to all Trades and the KZNPA General Electrical Specification are available at the office of the Secretary for Health – KwaZulu-Natal and can be obtained on request.**

1.2.6 **CERTIFICATE OF COMPLIANCE**

1.2.7 **Health and safety act 85(1993)**

Safety file must be produced and handed to safety department before commencement

PROVINCE OF KWAZULU-NATAL  
DEPARTMENT OF HEALTH  
**Urgent Flu clinic maintenance and repairs**  
**ZNQ NO: KEH 197**

TECHNICAL SPECIFICATIONS

**2. TECHNICAL SPECIFICATION**

**2.1 GENERAL**

This TECHNICAL SPECIFICATION shall be read in conjunction with all other sections of the SPECIFICATION and cognisance shall be taken of the clauses relevant to this particular installation, whether any specific clauses are referred to or not.

**Specifications**

**Health Preambles**

***DRYWALL PARTITIONS:***

**Studs**

50mm x 33.5mm x 0.5mm thick drywall galvanised steel studs are used. The studs to Receive aluminium extrusions clipped onto both sides of the stud. Framing to be securely

Fixed to walls, floor and ceilings where necessary. Stud connectors to be used to join Horizontal studs to vertical studs.

**Floor Track**

52mm x 25mm x 0.6mm galvanised sheet steel track to be used.

**Panels**

12,7mm thick tapered edged gypsum plasterboard panels used and decorated in situ with panels secured to either side of framework.

Patient care areas to be 12mm Supa Wood panels in framework as specified.

**Construction**

STANDARD PREAMBLES TO ALL TRADES 42

Internal walls are constructed by fixing drywall studs to floor track @ 600mm c/c. Wall and ceiling junctions are formed by fixing 84mm x 19mm aluminium ceiling and wall channel to wall or ceiling. The floor track is then fixed into this; alternatively, these components may be fixed simultaneously. The studs are then fixed to floor.

The partitions, unless otherwise described are to be 75mm thick and covered both sides with 12,7mm thick tapered edged gypsum board in 1200mm widths to height specified.

The gypsum boards are screwed @ +/- 300mm c/c at all intersections to the floor and head wall tracks and vertical studs.



Using self-drilling, self-tapping, rust proofed countersunk screws, with screw heads and joints between boards and between abutting edges of boards flushed up with an approved jointing material.

#### **Exposed Aluminium Framing**

Door frames, glazing termination and ceiling and wall channels to be natural anodised aluminium. 25 x 25 x 1.5 aluminium angle stuck to external corners of partitioning. 80mm high aluminium skirting glued in position.

#### **Glazing**

Aluminium glazing section is clipped onto the flanged end of the stud around the glazing perimeter. The glazing section has a recess to accept a rectangular clip-in glazing bead which enables 3mm-8mm thick glass to be received in the system. The glass is retained with various sizes of PVC glazing gasket.

#### **Termination**

Openings for louver frames, sliding doors and windows, serving hatches and partition ends are to be lined with the aluminium termination section.

#### **Skirting**

The system is designed to accept recessed base, female, 60mm high aluminium skirting.

#### **Sound Insulation**

75mm Fibreglass Cavity Bat with a 35g glass tissue or 75mm Isotherm "Acoustisorb" mineral wool blanket is to be installed between studding before fixing final outer panel. All work is to be executed by a firm specialising in this type of work and all to the approval of the Department.

## 14. TILING

### **MATERIALS**

**River Sand:** —is to be clean, sharp, coarse sand, free from all impurities, washed if so directed and complying with SANS Specification 1090.

**Plaster Sand:** — for wall backings is to be clean, sharp, free from impurities, washed if so directed and complying with SANS Specification 1090.

**Cement:** —unless otherwise specified, is to be Portland cement of normal setting quality complying with SANS Specification 471 and must be used fresh. Cement containing more than 15 % blast furnace slag will not be permitted to be used

**Water:** —is to be clean, fresh and free from injurious amounts of acids, alkalis and other organic substances.

**MEASUREMENT OF CONSTITUENT PARTS OF BACKINGS, ETC.:** — Cement and sand are to be measured exactly by means of gauge boxes or purpose made wheelbarrows. Part filling or heaping of normal wheelbarrows will not be permitted:

Water is to be accurately measured for each batch to approval.

Waterproofing compounds, where specified, are to be added to the mixture in the quantities recommended by and in strict accordance with the manufacturers' instructions.

### **MOVEMENT JOINTS:-**

Aluminium Structural Screed joints bolted to slab to be capable of total movement of minimum of 5mm either way with flexible PVC Hospital Insert.

Movement joints to be in high traffic area's as "Migua" FV35/1500 or "Kirk" ASSJ390H of approved height with hospital insert bolted to slab before screeding.

Metal movement joints in low traffic area's with hospital insert strips..

### **PAINTING**

**MATERIALS:** — Proprietary materials where specified are to be of the brand specified or other approved by the Department.

All primers, emulsion paints, enamels, stains, varnishes, etc. are to comply with the relevant SANS Specification.

Paints, etc. shall be suitable for application on the surfaces to which they are being applied and those used externally shall be of exterior quality or suitable for exterior use.

For any particular work the priming coat and subsequent coats of paint are to be executed with paints from the same manufacturer and in accordance with that manufacturer's instructions.

The materials are to be brought to the site in unopened containers and no adulteration will be permitted, except thinners of a quantity and quality directed by the manufacturer.

The Department shall at all times be permitted to take samples for testing purposes from open containers of any brand of paint being used on the work.

All materials, if and when required by the Department, will be subject to tests by the South African Bureau of Standards, and the cost of such tests, should the material under test not meet the requirements of this specification, shall be borne by the Contractor. Fillers and stoppings are to be suitable for use with the material being filled or stopped and to the approval of the Department.

**PREPARATORY WORK:** — All new and existing surfaces are to be thoroughly dry and are to be cleaned of all dust, dirt, grease, oil, rust, scale, efflorescence, fungus, loose or flaking material, etc. rubbed down, stopped, filled, knotted and sanded smooth as required in accordance with the paint manufacturer's recommendations and to the approval of the Department prior to the application of paint, etc.

Ceilings are to have nail heads, including those to cornices and cover strips, primed and stopped up as necessary and rubbed down smooth.

Asbestos cement shall be primed with an approved alkali resistant primer before the application of subsequent coats which are not, in themselves, alkali resistant.

Iron, steel and other ferrous metals shall be cleaned in accordance with SANS Code of Practice 064 to remove rust, scale, grease, oil, etc. and the surface brought to a bright metallic condition.

Galvanized iron and zinc shall be cleaned in accordance with SANS Code of Practice 062 to remove the manufacturer's temporary protective coating, white rust, etc.

Other non-ferrous metals shall be thoroughly cleaned to remove all milling oils, temporary protective coatings, etc. and the surface abraded with fine water-paper and white spirit.

Woodwork to be painted shall have all knots and resinous areas treated with an approved knotting, the surface shall then be primed and all holes, etc. stopped and rubbed down smooth,

Woodwork to be oiled, stained, varnished, etc. shall be free of all stains, pencil marks and other surface discolorations and all holes, etc. stopped with tinted stopping and rubbed down smooth.

In preparing existing glazed sashes and sash doors, all loose putty is to be removed, the rebates primed and glass re-sprigged and re-puttied as necessary before the painting is commenced.

Previously distempered or lime washed surfaces to receive any other type of paint, are to have the existing distemper or lime wash completely removed by scraping or wire brushing and the surfaces treated with an approved bonding liquid.

Where existing paint film are in good condition any flaking or bared patches are to be properly feathered into the surrounding paint and spot primed as necessary.

Where existing paint films are in poor condition and require to be removed completely, they are to be removed by means of wire brushing, paint remover, burning off, or other approved method. Paint removers shall be free of wax and caustic substances and shall preferably be of water rinseable type. When burning off paint from wood, care must be taken to avoid charring the wood.

The final state of preparatory work to existing decorated surfaces shall in all cases produce in the finished decorated surfaces a condition similar to new work.

The Contractor will be held responsible for the proper and adequate preparation of the surfaces and any work which fails to meet the manufacturer's recommendations must be made good at the Contractor's expense to the satisfaction of the Department.

**APPLICATION OF PAINTS, ETC.:** — Painting may be carried out by brush, roller or spray as recommended by the manufacturer and to the approval of the Department. All paints, etc. are to be applied in strict accordance with the manufacturer's instructions. Each coat of paint is to be adequately and permanently keyed onto the previous coat or surface and shall be evenly distributed and continuous and shall dry to a smooth film, free from sags, runs or other imperfections. Each coat of paint is to be of a colour distinctive from previous or succeeding coats.

All painting must be done in accordance with a colour scheme which will be provided by the Department, and rates for painting etc. are to include for all cutting in of contrasting colours and masking as required. No distinction has been made where more than one colour of the same material is required on the walls or ceiling of the same room.

Samples of colours for the final coats are to be prepared in all cases to the approval of the Department and all work must be finished to the approved colours.

Backs of wood door and similar frames and the surfaces of other new or prefixed joinery in contact with brickwork, etc. and built in as the work proceeds, shall be primed or sealed before building in to prevent moisture seeping into the wood from the mortar bedding.

Tongued and grooved and rebated edges of boards in batten doors and other such like inaccessible parts of new joinery shall, before assembly, be primed, or where the joinery is to receive a finish other than paint, be given one coat of such other finishing material.

All new external structural timbers shall be primed before the timbers are fixed in position and shall include all surfaces such as backs of fascias and barge boards.

**RATES:** — Rates for painting, etc. are to include for all preparatory work, and where spraying is employed, are to include or adequately masking all surrounding areas.

Where diameters of pipes are stated these are the nominal internal diameters, and rates for painting pipes are to include for painting the holderbats, hangers, clips, etc. supporting the pipes.

Rates are to include for providing all necessary dust sheets, covers, etc. taking all necessary precautions to prevent marking the surfaces of joinery, walls, floors, glass, electrical fittings, etc. All surfaces disfigured or otherwise damaged shall be completely renovated or replaced as necessary to the approval of the Department at the Contractor's own expense.

## **DRYWALL PARTITIONS:**

### **Studs**

50mm x 33.5mm x 0.5mm thick drywall galvanised steel studs are used. The studs to receive aluminium extrusions clipped onto both sides of the stud. Framing to be securely fixed to walls, floor and ceilings where necessary. Stud connectors to be used to join horizontal studs to vertical studs.

### **Floor Track**

52mm x 25mm x 0.6mm galvanised sheet steel track to be used.

### **Panels**

12,7mm thick tapered edged gypsum plasterboard panels used and decorated in situ with panels secured to either side of framework.

Patient care areas to be 12mm Supa Wood panels in framework as specified.

Construction

## **STANDARD PREAMBLES TO ALL TRADES 42**

Rev 3 January 2009

Internal walls are constructed by fixing drywall studs to floor track @ 600mm c/c. Wall and ceiling junctions are formed by fixing 84mm x 19mm aluminium ceiling and wall channel to wall or ceiling. The floor track is then fixed into this; alternatively, these components may be fixed simultaneously. The studs are then fixed to floor.

The partitions, unless otherwise described are to be 75mm thick and covered both sides with 12,7mm thick tapered edged gypsum board in 1200mm widths to height specified.

The gypsum boards are screwed @ +/- 300mm c/c at all intersections to the floor and head wall tracks and vertical studs.

Using self-drilling, self-tapping, rust proofed countersunk screws, with screw heads and joints between boards and between abutting edges of boards flushed up with an approved jointing material.

### **Exposed Aluminium Framing**

Door frames, glazing termination and ceiling and wall channels to be natural anodised aluminium. 25 x 25 x 1.5 aluminium angle stuck to external corners of partitioning. 80mm high aluminium skirting glued in position.

### **Glazing**

Aluminium glazing section is clipped onto the flanged end of the stud around the glazing perimeter. The glazing section has a recess to accept a rectangular clip-in glazing bead which enables 3mm-8mm thick glass to be received in the system. The glass is retained with various sizes of PVC glazing gasket.

### **Termination**

Openings for louver frames, sliding doors and windows, serving hatches and partition ends are to be lined with the aluminium termination section.

### **Skirting**

The system is designed to accept recessed base, female, 60mm high aluminium skirting.

Sound Insulation

75mm Fibreglass Cavity Bat with a 35g glass tissue or 75mm Isotherm "Acoustisorb" mineral wool blanket is to be installed between studding before fixing final outer panel. All work is to be executed by a firm specialising in this type of work and all to the approval of the Department.

#### 8. FLOOR COVERINGS, PLASTIC LININGS, ETC.

### **SANITARY PLUMBING AND FITTINGS, WASTE, VENTILATION AND ANTI-SIPHON PIPES**

(a) **Unplasticised polyvinyl chloride (UPVC) pipes and fittings** shall be of approved manufacture marked with the manufacturer's name and trade name, the nominal bore and the South African Bureau of Standards mark and shall comply with SANS Specification 967. Joints shall be made with injection moulded fittings in accordance with the manufacturer's instructions and SANS Code of Practice 0112. The pipes must be fixed clear of the finished wall face with aluminium alloy holderbats fitted with plastic cushion strips with the holderbats fixed to plugs in wall.

(b) **Polypropylene pipes and fittings** shall be of approved manufacture and shall have a mechanical form of jointing. Pipes and fittings are to be fixed and jointed in accordance with the manufacturer's instructions.

(c) **Multilayered pipes** shall be of approved manufacture and shall have a mechanical form of jointing. Pipes and fittings are to be fixed and jointed in accordance with the manufacturer's instructions.

**SANITARY FITTINGS:** — All sanitary ware must comply with SANS 497 Specifications and be fitted with Ball-O-Cock valves in supply lines.

**Wash hand basins** shall be of white glazed fireclay or vitreous china of the type and size specified. Basins shall have an integral overflow to non patient treatment facilities and be fitted with 32mm chromium plated waste union with flange and grating, rubber plug on chromium plated brass chain and, where required, tap hole stopper cemented in.

**WC pans** shall be of white glazed fireclay or vitreous china of the type specified with 'S' or 'P' trap with straight or side outlet and shall be fitted with single or double flap plastic seat as required, secured to pan with concealed brass holding down bolts. Pans shall be bedded on the concrete floors in 1:3 cement mortars. Pans in seclusion rooms and other public areas to be 'Gypsy' vandal proof – or other approved.

**Glazed ceramic urinals** of the bowl or stall type shall be of white glazed fireclay or vitreous china. Bowl urinals shall be fitted with 40mm chromium plated waste union, with flange and

domical grating and with spreader with flush pipe connector. Stall urinals shall be fitted with 75mm chromium plated waste union with flange and hinged domed grating and with spreader with flush pipe connector.

**Flushing cisterns** shall be as specified, either of white porcelain enamelled cast iron, white glazed fireclay, vitreous china or black plastic complying with SANS Specification 821, each with body and cover. Cisterns shall be a maximum of 11 litre capacity and the flushing apparatus shall be of brass, copper or other corrosion resistant metal, PVC or other approved plastic or of an approved ceramic material. All cistern lids must be able to be **screwed** down. Connections for flush pipe, inlet and overflow pipe must be provided in the body. Cisterns shall be fitted with 15mm brass ball valve with copper, PVC or polystyrene ball and with either chromium plated operating lever handle or galvanized steel pull chain and handle. A galvanized, white enamelled or chromium plated steel or copper flush pipe, of the required length, as specified, is to be jointed to the flush pipe connection on the body of the cistern and in the case of WC pans is to be fixed to the inlet of the pan with an approved patent adaptor. From the overflow connection on each cistern a 22mm copper overflow pipe, bent as required, shall be taken through wall to discharge externally, with ends splay cut and projecting 50mm beyond wall face, or where this is not possible, bent to discharge into WC pan.

**Baths** shall be enamelled cast iron baths of the type and size specified, holed for and fitted with chromium plated brass overflow union with grating, 40mm chromium plated brass waste union with flange and grating, rubber plug on chromium plated brass chain and fitted with adjustable cast iron feet. The fall along bottom of baths from head ends to outlets must be adequate for complete emptying.

Stainless steel sinks and drainers shall be of the types and sizes specified with exposed surfaces buffed to a satin finish and sound deadened on underside by application of an approved sound deadening coating. Splashbacks with tiling keys shall be provided at back and at ends against walls or as specified. Sink bowls are to be pressed out of single sheets with complete drainage to outlets and each bowl is to be fitted with integral built-in overflow with chromium plated brass grating and 40mm recessed waste outlets with chromium plated brass waste union with grating, rubber plug and chromium plated brass chain. Sink bowls, unless otherwise specified, are to be 450 x 355 x 140mm deep. Drainers are to be pressed out of single sheets and are to have pressed flutes to give complete drainage.

(a) For domestic use — Sinks shall comply with SANS Specification 242 and shall be manufactured from A.I.S.I. Type 430 stainless steel 0.8mm thick for units not exceeding 2,4m long and from stainless steel 1.2mm thick for units exceeding 2,4m Long. -

(b) For hospital use and laboratories — Sinks shall be manufactured from A.I.S.I. Type 304 stainless steel 0.9mm thick for units not exceeding 2.4m long and from stainless steel 1.2mm thick for units exceeding 2.4m long.

**Stainless steel wash hand basins and wash troughs** shall be of the types and sizes specified complying with SANS Specification 906, with exposed surfaces buffed to a satin finish and sound deadened on underside by application of an approved sound deadening coating. Each basin or wash trough in non patient treatment area's are to be fitted with integral built-in overflow with chromium plated brass grating and 40mm recessed waste outlet with chromium plated brass waste union with grating, rubber plug and chromium plated brass chain.

**Stainless steel urinals** shall be of the types and sizes specified complying with SANS Specification 924 and shall be manufactured from A.I.S.I. Type 304 stainless steel, 1.2mm thick, buffed to a satin finish and sound deadened at back by application of an approved sound deadening coating. The back and sides of urinals are to be made rigid by means of integral pressed ribs or by bowing. Edges at sides and top are to have plaster key. Tread plates are to be ribbed and the front edges are to be stiffened and bent to form key for floor finish. The trough shall be a minimum of 125mm wide and half round in section with all corners radiused and shall fall to ensure complete drainage to 75mm recessed outlet with



chromium plated domed hinged grating and frame.

**RATES FOR SANITARY WARE:** — shall include for the supply and fixing of the units as specified and for cleaning, washing and leaving in a satisfactory condition on completion.



VL-703600WH

Hygia wall hung medical basin with medical elbow operated tap – A modified version of the Cobra 515/055-21



Cobra 515/055-21 wall mounted elbow action medical tap

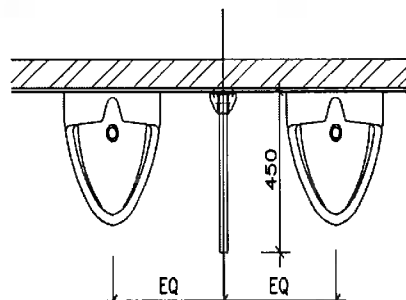
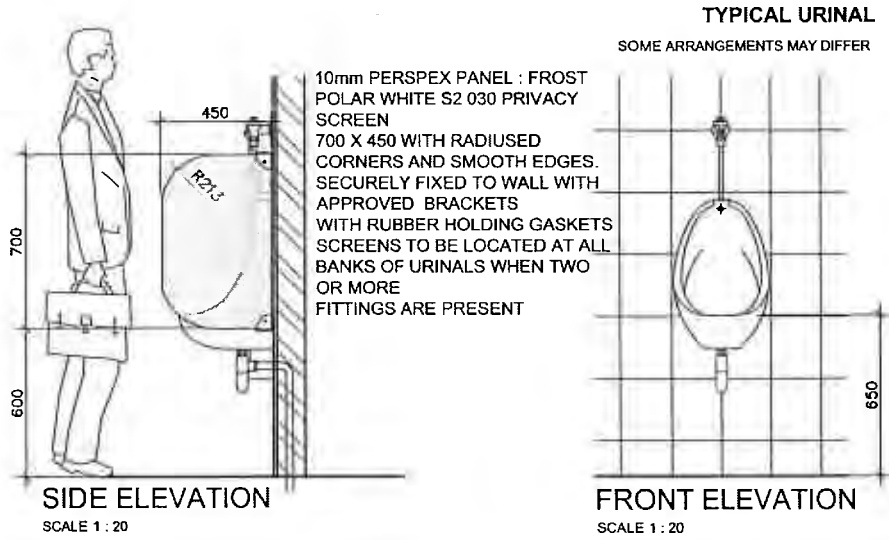

CHROMIUM PLATED DOMICAL GRATING (CODE: 8787Z0) AND CHROMIUM PLATED TOP INLET SPREADER (CODE: 7054Z1), COBRA FLUSH VALVE FJ6000, FIXED ON AND INCLUDING TWO HANGER BRACKETS (CODE: 8127Z0)(URINAL DIVISION. WITH COBRA WATERTech 32MM CHROME PLATED DEEP SEAL BOTTLE TRAP WITH OUTLET FOR 50MM PVC (CODE: 345/50).

F3a FITTINGS WILL REQUIRE NEW PLUMBING AND DRAINAGE

## WC BASIN

SOME ARRANGEMENTS MAY DIFFER

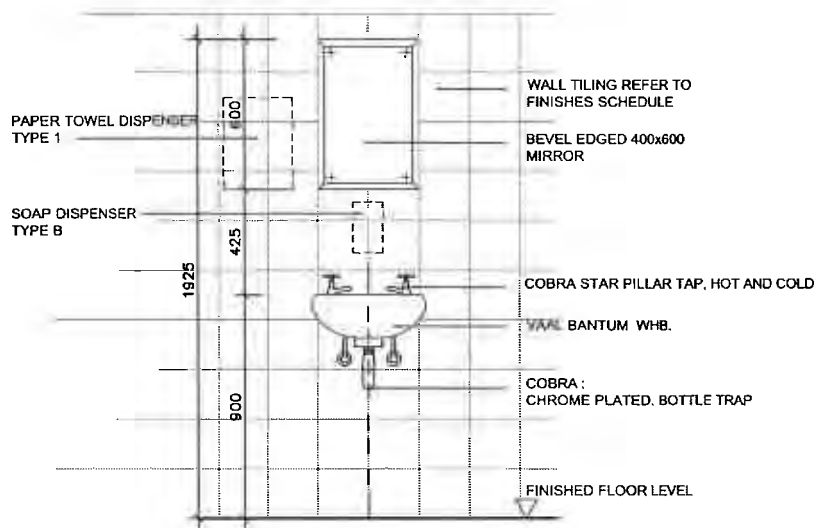

VAAL SANITARYWARE DAISY VITREOUS CHINA WALL MOUNTED BASIN  
COLOUR WHITE (CODE: 7008), SIZE 510 X 400MM  
WITH SEMI PUNCHED TAP HOLES, INTEGRATED OVERFLOW AND COBRA 309-40 ANTI-THEFT CHROME PLATED PLUG  
INSTALLED IN ACCORDANCE WITH MANUFACTURERS INSTRUCTIONS AND SEALED WITH SILICONE SEALANT WHERE  
BASIN MEETS WALL

2No. COBRA WATERTECH XENA XE-214-15 PILLAR TAPS, WITH HOT AND COLD WATER INDICATORS  
MANUFACTURED IN ACCORDANCE WITH SANS 226:2004 TYPE 2

COBRA CHROME PLATED BOTTLE TRAP 340P, TAIL PIPE C-342/1 AND WALL FLANGE C-342/3  
COBRA WASTE 303 SLOTTED WITH 62mm FLANGE  
REGULATING VALVE COBRA 232-10 WITH SLIDING WALL FLANGE AND FLEXI TUBE TO SUIT

MIRROR 400 x 600 BEVELED EDGED MIRROR WITH DOMED CAPPED SCREWS

PAPER TOWEL DISPENSER TYPE 1 - SERRA FLAT FOLDED PAPER TOWEL DISPENSER COMPLETE WITH LOCK & KEY  
GRADE 304 STAINLESS STEEL SATIN FINISH A735 WITH 450 C FOLD TOWEL CAPACITY SUPPLIED WITH SERRA  
DISPOSOR SLIMLINE WALL BIN IN SATIN STAINLESS STEEL FINISH.

SOAP DISPENSER TYPE B - SERRA NOX3 GRADE 304 STAINLESS STEEL SATIN FINISH SOAP DISPENSER WITH 1.25l  
CAPACITY SUPPLIED COMPLETE WITH KEY

### **3. SCOPE OF WORKS.**

The work to be carried out under this contract includes the OTO maintenance and repairs.

### **Flu clinic maintenance and repairs**

#### **General**

- 1. Allow for excavation backfilling and repairs to surfaces.**
- 2. Allow for the plumbing materials as specified**
- 3. Only class 02 copper must be used inside.**

#### ***PARTITIONING DRY WALL***

- Supply and install dry wall partitioning in consultation number one and two
- Ensure that dry wall is connected to existing wall
- Make a skeleton of dry wall with purlin 4/5
- length of dry wall must be 3m from existing wall Height must be 2.5 m
- supply and install aluminum curtain rails both side of consulting room
- 50mm x 33.5mm x 0.5mm thick drywall galvanised steel studs are used. The studs to
- Receive aluminium extrusions clipped onto both sides of the stud. Framing to be securely
- Internal walls are constructed by fixing drywall studs to floor track @ 600mm c/c. Wall
- The floor track is then fixed into this; alternatively, these components may be fixed simultaneously. The studs are then fixed to floor
- The partitions, unless otherwise described are to be 75mm thick and covered both sides
- with 12,7mm thick tapered edged gypsum board in 1200mm widths to height specified.
- The gypsum boards are screwed @ +/- 300mm c/c at all intersections to the floor and head
- wall tracks and vertical studs.
- Using self-drilling, self-tapping, rust proofed countersunk screws, with screw heads and
- joints between boards and between abutting edges of boards flushed up with an approved jointing material

NB Refer to page 4 for complete specification for dry wall

### ***Aluminum windows***

- Remove broken aluminum louver window frame and replace with new one to be same with existing 2m x 1.3 m x 6 mm thickness of glass
- Supply and install new mechanism and aluminum hinges
- Only frame will be aluminium the rest will be made shutter proof glass 6mm thick

### ***Doors***

- Remove broken main double door frame and replace with new aluminum double door
- Only frame will be aluminium the rest will be made shutter proof glass 6mm thick.
- Supply and install aluminium shutter proof glass double door 6 mm thick opening outwards and door must be lockable with union aluminium door lock.
- Ensure that each door must be hanged with three hinges.
- Supply and install folding door in dolphin area 3m x 1.2m to separate green area and red area from wall to wall

### ***Ceiling boards***

- Remove broken ceiling boards and replace with nu tech ceiling boards.
- Replace all rotten 38x38 battens.
- Supply and install new cover strip and cornice to cover the gap between wall and the ceiling boards.
- Used self-tipping screws to install ceiling boards.

### ***Hand basin***

- Supply Hygia wall hung medical basin with medical elbow operated tap – A modified version of the Cobra 515/055-21
- Supply and install new 15mm isolate valves
- Supply and install chrome plated new battle trap 340p
- Remove all 50 mm PVC pipe under the basin and replace with new one
- Refer to page 14 for specification

### ***Ablutions***

- Supply and install flush master FJ2.00 with pan connector C-FM8-20 and offset flush pipe FJTS.7
- Ensure that you connect to existing line waste and supply water line
- Supply and install sluice room sink mixer to be elbow action medical mixer cobra 521-21 and supporting chromed bow bracket
- Supply and install 150 L geyser to supply all basin with hot water and use only class 02 copper pipe to supply hand basins
- Refer to page 13 for full specification

**SCHEDULE OF RATES**

**WORK TO BE DONE AT KING EDWARD HOSPITAL AND SCHEDULE OF PRICES:**

Item	DESCRIPTION	UNIT	QTY	RATE/ UNIT		TOTAL	
				R	c	R	c
	<b>INSTITUTION:KING EDWARD HOSPITAL</b> <b>ZNQ NO: KM</b> All rates quoted shall be inclusive of transport, Labour and profit. The Tenderer is advised that the buildings are Occupied.						
	<b>PROPRIETARY ARTICLES:</b> All equipment and material used in this contract shall be that which is specified or other SABS approved.						
	<b>PARTITIONING DRY WALL</b>						
01	Supply and install dry wall partitioning in consultation number one and two length of dry wall must be 3m from existing wall Height must be 2.5 m	M <sup>2</sup>	12				
02	Make a skeleton of dry wall with purlin 4/5	SUM UNIT					
03	supply and install aluminum curtain rails both side of consulting room	UNIT	02				
	<b>Aluminum windows</b>	UNIT	01				
01	Remove broken aluminums louver window frame and replace with new one to be same with existing 2m x1.3 m x 6 mm thickness of glass	UNIT	10				
02	Supply and install new mechanism and aluminum hinges	UNIT	06				
<b>CARRIED TO COLLECTION SUMMARY</b>						<b>R</b>	
<b>PS 1</b>							



**SCHEDULE OF RATES**

**WORK TO BE DONE AT KING EDWARD HOSPITAL AND SCHEDULE OF PRICES:**

Item	DESCRIPTION	UNIT	QTY	RATE/ UNIT		TOTAL	
				R	c	R	c
<b>INSTITUTION:KING EDWARD HOSPITAL</b> <b>ZNQ NO: KM</b> All rates quoted shall be inclusive of transport, Labour and profit. The Tenderer is advised that the buildings are occupied							
<b>PROPRIETARY ARTICLES:</b> All equipment and material used in this contract shall be that which is specified or other SABS approved.							
<b><i>Doors</i></b>							
01	Remove broken main double door frame and replace with new aluminum double door 2mx1.25 m, Only frame will be aluminium the rest will be made shutter proof glass 6mm thick.	UNIT	01				
02	Supply and install aluminium shutter proof glass double door 6 mm thick opening outwards and door must be lockable with union aluminium door lock.	UNIT	01				
03	Ensure that each door must be hanged with three hinges.	UNIT	06				
04	Supply and install folding door in dolphin area 3m x1.2m to separate green area and red area from wall to wall	UNIT	01				
<b><i>Ceiling boards</i></b>							
01	Remove broken ceiling boards and replace with nu tech ceiling boards.	M <sup>2</sup>	25				
02	Replace all rotten 38x38 battens	SUM					
02	Supply and install new cover strip and cornice to cover the gap between wall and the ceiling boards.	SUM					
04	Used self-typing screws to install ceiling boards.	SUM					
<b><i>Hand basin</i></b>							
01	Supply Hygia wall hung medical basin with medical elbow operated tap – A modified version of the Cobra 515/055-21	UNIT	06				
02	Supply and install new 15mm isolate valves	UNIT	06				
03	Supply and install chrome plated new battle trap 340p	UNIT	06				
04	Remove all 50 mm PVC pipe under the basin and replace with new one	UNIT	06				
05	Refer to page 14 for specification						
<b>CARRIED TO COLLECTION SUMMARY</b>						<b>R</b>	
<b>PS 2</b>							

**SCHEDULE OF RATES**

WORK TO BE DONE AT KING EDWARD HOSPITAL AND SCHEDULE OF PRICES:

Item	DESCRIPTION	UNIT	QTY	RATE/ UNIT		TOTAL	
				R	c	R	c
	<p><b><u>INSTITUTION:KING EDWARD HOSPITAL</u></b>  <b><u>ZNQ NO: KM</u></b>                      All rates quoted shall be inclusive of transport, Labour and profit.                      The Tenderer is advised that the buildings are occupied</p>						
	<p><b><u>PROPRIETARY ARTICLES:</u></b>                      All equipment and material used in this contract shall be that which is specified or other SABS approved.</p>						
	<b><i>Ablutions</i></b>						
	Supply and install flush master FJ2.00 with pan connector C-FM8-20 and offset flush pipe FJTS.7	UNIT	03				
	Ensure that you connect to existing line waste and supply water line	UNIT	03				
	Supply and install sluice room sink mixer to be elbow action medical mixer cobra 521-21and supporting chromed bow bracket	UNIT	01				
	Supply and install 15 L geyser to supply all basin with hot water and use only class 02 copper pipe to supply hand basins	UNIT	01				
	Refer to page 13 for full specification						
						R	
<b>CARRIED TO COLLECTION SUMMARY</b>							
<b>PS 3</b>							

**PROJECT**  
**DESCRIPTION:**

**ZNO NO:** \_\_\_\_\_

**NOTE:**

THIS COLLECTION SUMMARY MUST BE COMPLETED IN FULL BY THE CONTRACTOR AND RETURNED TOGETHER WITH THE QUOTATION FORM.

Collection Summary	PS 1	R	
Collection Summary	PS 2	R	
Collection Summary	PS 3	R	
Safety requirements		R	
10% Contingencies		R	
Sub total		R	

\_\_\_\_\_  
\_\_\_\_\_  
**Company Director/ Company name**

**KEH-Maintenance  
Project Policy**

1. Stores issue the Company an order number and company confirms.
2. Stores notify the maintenance department
3. The Company contacts the maintenance department within a period of 2 days to confirm that they have received an order number.
4. Company is given a period of 1 week to compile and submit a work plan, safety requirements as briefed by a safety officer (**In a table form**)
5. Presentation of an official order, work plan
6. No work will be commenced without submitting a work plan and a safety plan.
7. **Company must sign a contractors register and complete the daily job card (This will be done on a daily basis with no fail)**
8. There will be progress meeting every week depending on the project period.

### Evaluation criteria

1. The rates must be clear and be on the attached schedule.
2. Collection summary.
3. Schedule of references
4. Detailed work plan showing the all the **mile stones**. (to cover the contract period)
5. Valid CIDB grading SO,GB-level 3
6. Qualification of artisan
7. References

\_\_\_\_\_  
Company Director/ Company name

\_\_\_\_\_  
Sign

\_\_\_\_\_  
Date

PROVINCE OF KWAZULU-NATAL  
DEPARTMENT OF HEALTH

**Flu clinic maintenance and repairs**

**ZNQ NO:** \_\_\_\_\_

### SCHEDULE OF RATES

#### 3.1 ITEMS AND PRICING

The Department reserves the right to place an order for any quantities of items included in the Schedules. The Schedule of Rates must also not be assumed to include and describe every detail of the supply requirement, but must be taken and read in conjunction with the other parts of the document. Thus the supplier shall not have claim for further payment in respect of any order which may be described or implied in the contract, although apparently no corresponding items are given in the Schedule of Rates. **The supplier shall be deemed to have satisfied himself before quoting as to the correctness and sufficiency of his quote for the contract and of the rates and prices stated in the Schedule of Rates.**

**3.2 TAX AND DUTIES**

Prices, quoted and paid, must include all customs, excise and import duties, and any other tariffs or taxes levied by the government or statutory body having jurisdiction on the goods provided under this contract, including Value Added Tax (applicable to the current rate).

**3.3 RATES**

Except where provision is made in the Schedule of Rates, the rates and prices inserted shall be the full rates and prices for the service delivered described under the respective items and shall cover all Labour, transport, overhead charges and profit, etc. as well as the general liabilities, obligations and risks arising out of the Conditions of Contract, the overhead charges and profit being spread proportionately over the rates of the relative items in the Schedule of Rates

**OFFICIAL BRIEFING SESSION / SITE INSPECTION CERTIFICATE KING EDWARD HOSPITAL**

Site/Security Office  
King Edward Hospital  
involved:

Flu clinic maintenance and repairs

Quotation No.  
: ZNQ NO.: \_\_\_\_\_

THIS IS TO CERTIFY THAT ..... OF  
( \_\_\_\_\_ ) VISITED AND INSPECTED THE SITE  
ON..... (DATE) AND IS THEREFORE FAMILIAR WITH THE  
CIRCUMSTANCES AND THE SCOPE OF THE SERVICE TO BE RENDERED.

.....  
**SIGNATURE OF TENDERER OR AUTHORISED REPRESENTATIVE**

DATE:.....

.....  
**SIGNATURE OF DEPARTMENTAL REPRESENTATIVE**

**DEPARTMENTAL STAMP:**

DATE:.....

**SCHEDULE OF REFERENCES**

References of previous work completed for the department of health or other to be listed below.

PLACE WORK WAS DONE	CONTACT PERSON	PHONE NUMBER	JOB COMPLETED

**NB. If this is not filled, your document will not be evaluated.**

**SIGNATURE OF TENDERER:.....**

**DATE: .....**