



# KZN Health Intranet

KZN HEALTH

- HOME
- CORPORATE INFORMATION
- COMPONENTS
- DIRECTORY
- DISTRICT OFFICES
- HEALTH FACILITIES

KZN Health > Components > Supply Chain Management

## AdvertQuote

Submit | Save | Save As... | Close | Print Preview



## Quotation Advert

Opening Date:	2020-10-22	
Closing Date:	2020-11-04	
Closing Time:	11:00	

### INSTITUTION DETAILS

Institution Name:	St Apollinaris hospital	
Province:	KwaZulu-Natal	
Department or Entity:	Department of Health	
Division or section:	Central Supply Chain Management	
Place where goods / services is required	ST APOLLINARIS HOSPITAL	
Date Submitted	2020-10-21	

### ITEM CATEGORY AND DETAILS

Quotation Number:	ZNQ: 132/2020/2021
Item Category:	Services
Item Description:	CONSTRUCTION OF WAITING AREA AT KILMUN CLINIC

Quantity (if supplies)

### COMPULSORY BRIEFING SESSION / SITE VISIT

Select Type:	Compulsory Briefing Session	
Date :	2020-10-27	
Time:	13:30PM	
Venue:	KILMUN CLINIC (NOT ST APOLLINARIS HOSPITAL)	





QUOTES CAN BE COLLECTED FROM: WEBSITE OR VISIT THE HOSPITAL BEFORE THE DATE OF SITE MEETING

QUOTES SHOULD BE DELIVERED TO: SECURITY TENDER BOX ( NO EMAIL DOCUMENTS WILL BE CONSIDERED )

ENQUIRIES REGARDING THE ADVERT MAY BE DIRECTED TO:

Name:	MS F S ZUMA
Email:	
Contact Number:	0398338054/8091
Finance Manager Name:	MRS M B KHESWA
Finance Manager Signature:	

No late quotes will be considered

 Submit |  Save | Save As... |  Close |  Print Preview

Print this page

### Note:

1. The completed Quotation Advert must be printed and signed by the Finance manager.
2. A signed copy of the Quotation Advert must be scanned and emailed to web administration: [SCM.Advert@kznhealth.gov.za](mailto:SCM.Advert@kznhealth.gov.za) for uploading to the department website.
3. N.B if the scanned copy submitted is not a signed copy (by the finance manager), the advert/award WILL NOT be uploaded.

Site Updated:21 October, 2020, 01:17 pm

The materials on this website may be copied for non-commercial use as long as our copyright notice and website address are included.

Copyright © KwaZulu-Natal Department of Health, 2000

Contact the Web Administrator

OFFICIAL PRICE PAGE FOR QUOTATIONS

ZNQ NUMBER: 132/2020/2021

DESCRIPTION: CONSTRUCTION OF KILMUN WAITING AREA

SIGNATURE OF BIDDER ..... DATE.....  
 [By signing this document I hereby agree to all terms and conditions]

CAPACITY UNDER WHICH THIS QUOTE IS SIGNED.....

Item No	Quantity	Description	Brand & model	Country of manufacture	Price	
					R	c
		SERVICE PROVIDER TO DO CONSTRUCTION OF				
		WAITING AREA SHELTER FOR PATIENTS AT				
		KILMUN CLINIC ,THE SHELTER TO WITHSTAND				
		ALL KINDS OF WEATHER ( RAIN ,COLD AND SUN)				
		THE SERVICE PROVIDER MUST BE CIDB GRADE				
		1GB OR ABOVE				
		SPECIFICATION IS ATTACHED				
		CLEAR PRINTED CSD NUMBER AND UNIQUE				
		REFERENCE NUMBER MUST BE ATTACHED				
VALUE ADDED TAX @ 15% (Only if VAT Vendor)						
TOTAL QUOTATION PRICE (VALIDITY PERIOD 60 Days)						

Does This Offer Comply With The Specification? Is The Price Firm?	Does The Article Conform To The S.A.N.S. / S.A.B.S. Specification? State Delivery Period E.G. E.G. 1day, 1week
--	---

Enquiries regarding the <u>quote</u> may be directed to: Contact Person: <u>F. S. Zungu</u> Tel: <u>039 833 8054</u> E-Mail Address: .....	Enquiries regarding <u>technical information</u> may be directed to: Contact Person: <u>M. Guwanda</u> Tel: <u>039 833 8065</u>
--	--

STANDARD QUOTE DOCUMENTATION SUPPLY CHAIN MANAGEMENT OVER R30 000.00

YOU ARE HEREBY INVITED TO QUOTE FOR REQUIREMENTS AT: ST APOLLINARIS HOSPITAL		
DATE ADVERTISED: 22/10/2020	CLOSING DATE: 04/11/2020	CLOSING TIME: 11:00
FACSIMILE NUMBER: N/A	E-MAIL ADDRESS: N/A (NETWORK ERROR)	
PHYSICAL ADDRESS: CENTOCOW MISSION CREIGHTON 3263		

ZNQ NUMBER: 132/2020/2021

DESCRIPTION: CONSTRUCTION OF WAITING AREA AT KILMUN CLINIC

CONTRACT PERIOD: ADHOC (if applicable) VALIDITY PERIOD 60 Days SARS PIN:

CENTRAL SUPPLIER DATABASE REGISTRATION (CSD) NO. [grid]

UNIQUE REGISTRATION REFERENCE [grid]

DEPOSITED IN THE QUOTE BOX SITUATED AT (STREET ADDRESS)

SECURITY TENDER BOX

EMAILED QUOTES WILL NOT BE CONSIDERED

Bidders should ensure that quotes are delivered timeously to the correct address. If the quote is late, it will not be accepted for consideration.

The quote box is open from 08:00 to 15:30.

ALL QUOTES MUST BE SUBMITTED ON THE OFFICIAL FORMS – (NOT TO BE RE-TYPED)

THIS QUOTE IS SUBJECT TO THE PREFERENTIAL PROCUREMENT POLICY FRAMEWORK ACT AND THE PREFERENTIAL PROCUREMENT REGULATIONS, 2011, THE GENERAL CONDITIONS OF CONTRACT (GCC) AND, IF APPLICABLE, ANY OTHER SPECIAL CONDITIONS OF CONTRACT.

THE FOLLOWING PARTICULARS MUST BE FURNISHED (FAILURE TO DO SO WILL RESULT IN YOUR QUOTE BEING DISQUALIFIED)

NAME OF BIDDER

POSTAL ADDRESS

STREET ADDRESS

TELEPHONE NUMBER CODE.....NUMBER..... FACSIMILE NUMBER CODE.....NUMBER.....

CELLPHONE NUMBER

E-MAIL ADDRESS

VAT REGISTRATION NUMBER (If VAT vendor)

HAS A B-BBEE STATUS LEVEL VERIFICATION CERTIFICATE BEEN SUBMITTED? (SBD 6.1) YES NO

[A B-BBEE STATUS LEVEL VERIFICATION CERTIFICATE/SWORN AFFIDAVIT (FOR EMEs& QSEs) MUST BE SUBMITTED IN ORDER TO QUALIFY FOR PREFERENCE POINTS FOR B-BBEE]

DECLARATION OF INTEREST

1. Any legal person, including persons employed by the state<sup>1</sup>, or persons having a kinship with persons employed by the state, including a blood relationship, may make an offer or offers in terms of this invitation to quote (includes a price quotation, advertised competitive quote, limited quote or proposal). In view of possible allegations of favouritism, should the resulting quote, or part thereof, be awarded to persons employed by the state, or to persons connected with or related to them, it is required that the bidder or his/her authorised representative declare his/her position in relation to the evaluating/adjudicating authority where-
- the bidder is employed by the state; and/or
  - the legal person on whose behalf the bidding document is signed, has a relationship with persons/a person who are/is involved in the evaluation and or adjudication of the quote(s), or where it is known that such a relationship exists between the person or persons for or on whose behalf the declarant acts and persons who are involved with the evaluation and or adjudication of the quote.

2. In order to give effect to the above, the following questionnaire must be completed and submitted with the quote.

- 2.1. Full Name of bidder/representative..... 2.4. Company Registration Number: .....  
 2.2. Identity Number: ..... 2.5. Tax Reference Number: .....  
 2.3. Position occupied in the Company (director, trustee, shareholder\*):..... 2.6. VAT Registration Number: .....

2.7. The names of all directors / trustees / shareholders / members, their individual identity numbers, tax reference numbers and, if applicable, employee / persal numbers must be indicated in paragraph 3 below. [TICK APPLICABLE]

2.8. Are you or any person connected with the bidder presently employed by the state? YES NO

2.8.1. If so, furnish the following particulars:  
 Name of person / director / trustee / shareholder/ member: .....  
 Name of state institution at which you or the person connected to the bidder is employed:.....  
 Position occupied in the state institution: ..... Any other particulars:.....

2.8.2. If you are presently employed by the state, did you obtain the appropriate authority to undertake remunerative work outside employment in the public sector? YES NO

2.8.2.1. If yes, did you attach proof of such authority to the quote document?  
 (Note: Failure to submit proof of such authority, where applicable, may result in the disqualification of the quote.)

2.8.2.2. If no, furnish reasons for non-submission of such proof: .....

2.9. Did you or your spouse, or any of the company's directors / trustees / shareholders / members or their spouses conduct business with the state in the previous twelve months? YES NO

2.9.1. If so, furnish particulars:.....

2.10. Do you, or any person connected with the bidder, have any relationship (family, friend, other) with a person employed by the state and who may be involved with the evaluation and or adjudication of this quote? YES NO

2.10.1. If so, furnish particulars:.....

2.11. Are you, or any person connected with the bidder, aware of any relationship (family, friend, other) between any other bidder and any person employed by the state who may be involved with the evaluation and or adjudication of this quote? YES NO

2.11.1. If so, furnish particulars:.....

2.12. Do you or any of the directors / trustees / shareholders / members of the company have any interest in any other related companies whether or not they are bidding for this contract? YES NO

2.12.1. If so, furnish particulars:.....

**3. Full details of directors / trustees / members / shareholders.**  
 NB: The Department Of Health will validate **details of directors / trustees / members / shareholders** on CSD. It is the suppliers' responsibility to ensure that their details are up-to-date and verified on CSD. If the Department cannot validate the **information** on CSD, the quote will not be considered and passed over as non-compliant according to National Treasury Instruction Note 4 (a) 2016/17.

**4 DECLARATION**

I, THE UNDERSIGNED (NAME)..... CERTIFY THAT THE INFORMATION FURNISHED IN PARAGRAPHS 2.

I ACCEPT THAT THE STATE MAY REJECT THE QUOTE OR ACT AGAINST ME SHOULD THIS DECLARATION PROVE TO BE FALSE.

.....  
 Name of bidder Signature Position Date

<sup>1</sup> "State" means –  
 a) any national or provincial department, national or provincial public entity or constitutional institution within the meaning of the Public Finance Management Act, 1999 (Act No. 1 of 1999);  
 b) any municipality or municipal entity;  
 c) provincial legislature;  
 d) national Assembly or the national Council of provinces; or  
 e) Parliament.

\* "Shareholder" means a person who owns shares in the company and is actively involved in the management of the enterprise or business and exercises control over the enterprise.

## SPECIAL CONTRACT CONDITIONS OF QUOTATIONS

### 1. AMENDMENT OF CONTRACT

- 1.1. Any amendment to or renunciation of the provisions of the contract shall at all times be done in writing and shall be signed by both parties.

### 2. CHANGE OF ADDRESS

- 2.1. Bidders must advise the Department of Health (institution where the offer was submitted) should their address (*domicilium citandi et executandi*) details change from the time of bidding to the expiry of the contract.

### 3. GENERAL CONDITIONS ATTACHED TO THIS QUOTATION

- 3.1. The institution is under no obligation to accept the lowest or any quote.
- 3.2. The price quoted must include VAT (if VAT vendor). However, it must be noted that the department reserves the right to evaluate all quotations excluding VAT as some bidders may not be VAT vendors.
- 3.3. The bidder must ensure the correctness & validity of quote:
- (i) *that the price(s), rate(s) & preference quoted cover all for the work/item (s) & accept that any mistakes regarding the price (s) & calculations will be at the bidder's risk*
- 3.4. The bidder must accept full responsibility for the proper execution & fulfilment of all obligations conditions devolving on under this agreement, as the Principal (s) liable for the due fulfillment of this contract.
- 3.5. This quotation will be evaluated based on the 80/20 points system, specification & correctness of information. All required documentation must be completed in full and submitted.
- 3.6. Offers must comply strictly with the specification.
- 3.7. Only offers that meet or are greater than the specification will be considered.
- 3.8. Late quotes will not be considered.
- 3.9. Expired product/s will not be accepted. All products supplied must be valid for a minimum period of six months.
- 3.10. A bidder not registered on the Central Suppliers Database or verification has failed will not be considered.
- 3.11. All delivery costs must be included in the quote price, for delivery at the prescribed destination.
- 3.12. Only firm prices will be accepted. Such prices must remain firm for the contract period. Non-firm prices (including rates of exchange variations) will not be considered.
- 3.13. In cases where different delivery points influence the pricing, a separate pricing schedule must be submitted for each delivery point.
- 3.14. In the event of a bidder having multiple quotes, only the cheapest according to specification will be considered. Furthermore a verification will be done to identify if bidders have multiple companies and are quoting (cover-quoting) for this bid. In such instances only the cheapest bid according to specification will be considered.

### 4. SPECIAL INSTRUCTIONS AND NOTICES TO BIDDERS REGARDING THE COMPLETION OF THIS QUOTATION.

- 4.1. Unless inconsistent with or expressly indicated otherwise by the context, the singular shall include the plural and vice versa and with words importing the masculine gender shall include the feminine and the neuter.
- 4.2. Under no circumstances whatsoever may the quotation/bid forms be retyped or redrafted. Photocopies of the original bid documentation may be used, but an original signature must appear on such photocopies.
- 4.3. The bidder is advised to check the number of pages and to satisfy himself that none are missing or duplicated.
- 4.4. Quotation submitted must be complete in all respects.
- 4.5. Any alteration made by the bidder must be initialled.
- 4.6. Use of correcting fluid is prohibited
- 4.7. Quotation will be opened in public as soon as practicable after the closing time of quotation.
- 4.8. Where practical, prices are made public at the time of opening quotations.
- 4.9. If it is desired to make more than one offer against any individual item, such offers should be given on a photocopy of the page in question. Clear indication thereof must be stated on the schedules attached.

### 5. SPECIAL INSTRUCTIONS REGARDING HAND DELIVERED QUOTATIONS

- 5.1. Quotation shall be lodged at the address indicated not later than the closing time specified for their receipt, and in accordance with the directives in the quotation documents.
- 5.2. Each quotation shall be addressed in accordance with the directives in the quotation documents and shall be lodged in a separate sealed envelope, with the name and address of the bidder, the quotation number and closing date indicated on the envelope. The envelope shall not contain documents relating to any quotation other than that shown on the envelope. If this provision is not complied with, such quotations/bids may be rejected as being invalid.
- 5.3. All quotations received in sealed envelopes with the relevant quotation numbers on the envelopes are kept unopened in safe custody until the closing time of the quotation/bids. Where, however, a quotation is received open, it shall be sealed. If it is received without a quotation/bid number on the envelope, it shall be opened, the quotation number ascertained, the envelope sealed and the quotation number written on the envelope.
- 5.4. A specific box is provided for the receipt of quotations, and no quotation found in any other box or elsewhere subsequent to the closing date and time of quotation will be considered.

- 5.5. No quotation/bid sent through the post will be considered if it is received after the closing date and time stipulated in the quotation documentation, and proof of posting will not be accepted as proof of delivery.
- 5.6. Quotation documents must not be included in packages containing samples. Such quotations may be rejected as being invalid.

**6. SAMPLES**

- 6.1. In the case of the quote document stipulating that samples are required, the supplier will be informed in due course when samples should be provided to the institution. (This decreases the time of safety and storage risk that may be incurred by the respective institution). The bidders sample will be retained if such bidder wins the contract.
  - (i) If a company/s who has not won the quote requires their samples, they must advise the institution in writing of such.
  - (ii) If samples are not collected within three months of close of quote the institution reserves the right to dispose of them at their discretion.
- 6.2. **Samples must be made available when requested in writing or if stipulated on the document.**
  - (i) If a Bidder fails to provide a sample of their product on offer for scrutiny against the set specification when requested, their offer will be rejected. All testing will be for the account of the bidder.

**7. COMPULSORY SITE INSPECTION / BRIEFING SESSION**

7.1. Bidders who fail to attend the compulsory meeting will be disqualified from the evaluation process.

- (i) The institution has determined that a compulsory site meeting  YES  take place
- (ii) Date 10/27/20 Time 13:30 Place KILMUN

Institution Stamp:	Institution Site Inspection / briefing session Official  Full Name: ..... Signature: ..... Date: .....
--------------------	--

**8. STATEMENT OF SUPPLIES AND SERVICES**

8.1. The contractor shall, when requested to do so, furnish particulars of supplies delivered or services executed. If he/she fails to do so, the Department may, without prejudice to any other rights which it may have, institute inquiries at the expense of the contractor to obtain the required particulars.

**9. SUBMISSION AND COMPLETION OF SBD 6.1**

9.1. Should a bidder wish to qualify for preference points they must complete a SBD 6.1 document. Failure by a bidder to provide all relevant information required, will result in such a bidder not being considered for preference point's allocation. The preferences applicable on the closing date will be utilized. Any changes after the closing date will not be considered for that particular quote.

**10. TAX COMPLIANCE REQUIREMENTS**

- 10.1. In the event that the tax compliance status has failed on CSD, *it is the suppliers' responsibility to provide a SARS pin in order for the institution to validate the tax compliance status of the supplier.*
- 10.2. In the event that the institution cannot validate the suppliers' tax clearance on SARS as well as the Central Suppliers Database, *the quote will not be considered and passed over as non-compliant according to National Treasury Instruction Note 4 (a) 2016/17.*

**11. TAX INVOICE**

11.1. A tax invoice shall be in the currency of the Republic of South Africa and shall contain the following particulars:

- (i) the name, address and registration number of the supplier;
- (ii) the name and address of the recipient;
- (iii) an individual serialized number and the date upon which the tax invoice is issued;
- (iv) a description and quantity or volume of the goods or services supplied;
- (v) the official department order number issued to the supplier;
- (vi) the value of the supply, the amount of tax charged;
- (vii) the words tax invoice in a prominent place.

**12. PATENT RIGHTS**

The supplier shall indemnify the KZN Department of Health (here after known as the purchaser) against all third-party claims of infringement of patent, trademark, or industrial design rights arising from use of the goods or any part thereof by the purchaser.

### **13. PENALTIES**

- 13.1. If at any time during the contract period, the service provider is unable to perform in a timely manner, the service provider must notify the institution in writing/email of the cause of and the duration of the delay. Upon receipt of the notification, the institution should evaluate the circumstances and, if deemed necessary, the institution may extend the service provider's time for performance.
- 13.2. In the event of delayed performance that extends beyond the delivery period, the institution is entitled to purchase commodities of a similar quantity and quality as a substitution for the outstanding commodities, without terminating the contract, as well as return commodities delivered at a later stage at the service provider's expense.
- 13.3. Alternatively, the institution may elect to terminate the contract and procure the necessary commodities in order to complete the contract. In the event that the contract is terminated the institution may claim damages from the service provider in the form of a penalty. The service provider's performance should be captured on the service provider database in order to determine whether or not the service provider should be awarded any contracts in the future.
- 13.4. If the supplier fails to deliver any or all of the goods or to perform the services within the period(s) specified in the contract, the purchaser shall, without prejudice to its other remedies under the contract, deduct from the contract price, as a penalty, a sum calculated on the delivered price of the delayed goods or unperformed services using the current prime interest rate calculated for each day of the delay until actual delivery or performance.

### **14. TERMINATION FOR DEFAULT**

- 14.1. The purchaser, without prejudice to any other remedy for breach of contract, by written notice of default sent to the supplier, may terminate this contract in whole or in part:
  - (i) if the supplier fails to deliver any or all of the goods within the period(s) specified in the contract,
  - (ii) if the supplier fails to perform any other obligation(s) under the contract; or
  - (iii) if the supplier, in the judgment of the purchaser, has engaged in corrupt or fraudulent practices in competing for or in executing the contract.
- 14.2. In the event the purchaser terminates the contract in whole or in part, the purchaser may procure, upon such terms and in such manner as it deems appropriate, goods, works or services similar to those undelivered, and the supplier shall be liable to the purchaser for any excess costs for such similar goods, works or services.
- 14.3. Where the purchaser terminates the contract in whole or in part, the purchaser may decide to impose a restriction penalty on the supplier by prohibiting such supplier from doing business with the public sector for a period not exceeding 10 years.

### **15. FAILURE TO COMPLY WITH ABOVE WILL RESULT IN YOUR QUOTE BEING PASSED OVER.**



**PREFERENCE POINTS CLAIM FORM IN TERMS OF THE PREFERENTIAL PROCUREMENT REGULATIONS 2017**

This preference form must form part of all quotes invited. It contains general information and serves as a claim form for preference points for Broad-Based Black Economic Empowerment (B-BBEE) Status Level of Contribution

**NB: BEFORE COMPLETING THIS FORM, BIDDERS MUST STUDY THE GENERAL CONDITIONS, DEFINITIONS AND DIRECTIVES APPLICABLE IN RESPECT OF B-BBEE, AS PRESCRIBED IN THE PREFERENTIAL PROCUREMENT REGULATIONS, 2017.**

**1. GENERAL CONDITIONS**

- 1.1 The following preference point systems are applicable to all quotes:
- the 80/20 system for requirements with a Rand value of up to R50 000 000 (all applicable taxes included); and
- 1.2 The value of this quote is estimated to not exceed R50 000 000 (all applicable taxes included) and therefore the 80/20 preference point system shall be applicable.
- 1.3 Points for this quote shall be awarded for:
- (a) Price; and
  - (b) B-BBEE Status Level of Contributor.
- 1.4 The maximum points for this quote is allocated as follows:

	<b>POINTS</b>
<b>PRICE</b>	80
<b>B-BBEE STATUS LEVEL OF CONTRIBUTOR</b>	20
<b>Total points for Price and B-BBEE must not exceed</b>	<b>100</b>

- 1.5 Failure on the part of a bidder to submit proof of B-BBEE Status level of contributor together with the quote, will be interpreted to mean that preference points for B-BBEE status level of contribution are not claimed.
- 1.6 The purchaser reserves the right to require of a bidder, either before a quote is adjudicated or at any time subsequently, to substantiate any claim in regard to preferences, in any manner required by the purchaser.

**2. DEFINITIONS**

- (a) **"B-BBEE"** means broad-based black economic empowerment as defined in section 1 of the Broad-Based Black Economic Empowerment Act;
- (b) **"B-BBEE status level of contributor"** means the B-BBEE status of an entity in terms of a code of good practice on black economic empowerment, issued in terms of section 9(1) of the Broad-Based Black Economic Empowerment Act;
- (c) **"bid"** means a written offer in a prescribed or stipulated form in response to an invitation by an organ of state for the provision of goods or services, through price quotations, advertised competitive bidding processes or proposals;
- (d) **"Broad-Based Black Economic Empowerment Act"** means the Broad-Based Black Economic Empowerment Act, 2003 (Act No. 53 of 2003);
- (e) **"EME"** means an Exempted Micro Enterprise in terms of a code of good practice on black economic empowerment issued in terms of section 9 (1) of the Broad-Based Black Economic Empowerment Act;
- (f) **"functionality"** means the ability of a tenderer to provide goods or services in accordance with specifications as set out in the tender documents.
- (g) **"prices"** includes all applicable taxes less all unconditional discounts;
- (h) **"proof of B-BBEE status level of contributor"** means:
  - 1) B-BBEE Status level certificate issued by an authorized body or person;
  - 2) A sworn affidavit as prescribed by the B-BBEE Codes of Good Practice;
  - 3) Any other requirement prescribed in terms of the B-BBEE Act;
- (i) **"QSE"** means a qualifying small business enterprise in terms of a code of good practice on black economic empowerment issued in terms of section 9 (1) of the Broad-Based Black Economic Empowerment Act;
- (j) **"rand value"** means the total estimated value of a contract in Rand, calculated at the time of bid invitation, and includes all applicable taxes;

**3. POINTS AWARDED FOR PRICE**  
**3.1 THE 80/20 PREFERENCE POINT SYSTEMS**

A maximum of 80 points is allocated for price on the following basis:

$$P_s = 80 \left( 1 - \frac{P_t - P_{\min}}{P_{\min}} \right) \text{ Where}$$

- $P_s$  = Points scored for price of bid under consideration
- $P_t$  = Price of bid under consideration
- $P_{\min}$  = Price of lowest acceptable bid

**4. POINTS AWARDED FOR B-BBEE STATUS LEVEL OF CONTRIBUTOR**

4.1 In terms of Regulation 6 (2) and 7 (2) of the Preferential Procurement Regulations, preference points must be awarded to a bidder for attaining the B-BBEE status level of contribution in accordance with the table below:

B-BBEE Status Level of Contributor	Number of points (80/20 system)
1	20
2	18
3	14
4	12
5	8
6	6
7	4
8	2
Non-compliant contributor	0

**5. BID DECLARATION**

5.1 Bidders who claim points in respect of B-BBEE Status Level of Contribution must complete the following:

**6. B-BBEE STATUS LEVEL OF CONTRIBUTOR CLAIMED IN TERMS OF PARAGRAPHS 1.4 AND 4.1**

6.1 B-BBEE Status Level of Contributor: = .....(maximum of 20 points)

(Points claimed in respect of paragraph 7.1 must be in accordance with the table reflected in paragraph 4.1 and must be substantiated by relevant proof of B-BBEE status level of contributor.

**7. SUB-CONTRACTING**

(Tick applicable box)

7.1 Will any portion of the contract be sub-contracted?

YES	<input type="checkbox"/>	NO	<input type="checkbox"/>
-----	--------------------------	----	--------------------------

7.1.1 If yes, indicate:

- i) What percentage of the contract will be subcontracted.....%
- ii) The name of the sub-contractor.....
- iii) The B-BBEE status level of the sub-contractor.....

8. Whether the sub-contractor is an EME or QSE

(Tick applicable box)

iv) Specify, by ticking the appropriate box, if subcontracting with an enterprise in terms of Preferential Procurement Regulations, 2017:

YES	<input type="checkbox"/>	NO	<input type="checkbox"/>
-----	--------------------------	----	--------------------------

Designated Group: An EME or QSE which is at least 51% owned by:	EME √	QSE √
Black people		
Black people who are youth		
Black people who are women		
Black people with disabilities		
Black people living in rural or underdeveloped areas or townships		
Cooperative owned by black people		
Black people who are military veterans		
OR		
Any EME		
Any QSE		

9. DECLARATION WITH REGARD TO COMPANY/FIRM

9.1 Name of company/firm:.....

9.2 VAT registration number:.....

9.3 Company registration number:.....

9.4 TYPE OF COMPANY/ FIRM [TICK APPLICABLE BOX]

- Partnership/Joint Venture / Consortium
- One person business/sole propriety
- Close corporation
- Company
- (Pty) Limited

9.5 DESCRIBE PRINCIPAL BUSINESS ACTIVITIES

.....  
.....

9.6 COMPANY CLASSIFICATION [TICK APPLICABLE BOX]

- Manufacturer
- Supplier
- Professional service provider
- Other service providers, e.g. transporter, etc.

9.7 Total number of years the company/firm has been in business:.....

9.8 I/we, the undersigned, who is / are duly authorised to do so on behalf of the company/firm, certify that the points claimed, based on the B-BBE status level of contributor indicated in paragraphs 1.4 and 6.1 of the foregoing certificate, qualifies the company/ firm for the preference(s) shown and I / we acknowledge that:

- i) The information furnished is true and correct;
- ii) The preference points claimed are in accordance with the General Conditions as indicated in paragraph 1 of this form;
- iii) In the event of a contract being awarded as a result of points claimed as shown in paragraphs 1.4 and 6.1, the contractor may be required to furnish documentary proof to the satisfaction of the purchaser that the claims are correct;
- iv) If the B-BBEE status level of contributor has been claimed or obtained on a fraudulent basis or any of the conditions of contract have not been fulfilled, the purchaser may, in addition to any other remedy it may have –
  - (a) disqualify the person from the bidding process;
  - (b) recover costs, losses or damages it has incurred or suffered as a result of that person's conduct;
  - (c) cancel the contract and claim any damages which it has suffered as a result of having to make less favourable arrangements due to such cancellation;
  - (d) recommend that the bidder or contractor, its shareholders and directors, or only the shareholders and directors who acted on a fraudulent basis, be restricted by the National Treasury from obtaining business from any organ of state for a period not exceeding 10 years, after the *audi alteram partem* (hear the other side) rule has been applied; and
  - (e) forward the matter for criminal prosecution.

WITNESSES
1. ....
2. ....

..... SIGNATURE(S) OF BIDDERS(S)
DATE: .....
ADDRESS..... ..... .....

PROVINCE OF KWAZULU-NATAL  
DEPARTMENT OF HEALTH

ZNQ –

KILMUN CLINIC- CONSTRUCTION WAITING AREA SHELTER FOR PATIENTS AT  
KILMUN CLINIC.

**1.1 SCOPE OF CONTRACT**

This Contract is for the execution of the project indicated above.

**1.2 CONTRACT DRAWINGS**

Drawings attached (Drawing 1, 2, 3 and 4)

**1.3 CONDITIONS OF CONTRACT AND PRELIMINARIES**

**1.3.1 PERIOD OF CONTRACT**

Four (04) *Weeks* as the Contract Period for the completion of the Work from date of Site handover.

**1.3.2 CONTRACT GUARANTEE:**

The Successful Bidder will **NOT** be required to submit a contract guarantee.

**1.3.3 GUARANTEE PERIOD**

The guarantee period for the completion of the Structural work and all materials must be a minimum of Three (3) Calendar Months from the date of first delivery.

**1.3.4 SITE AND MODE OF PROCEDURE**

The work contained in this contract will be carried out on the site of the existing at **Kimun Clinic**.

The Bidder is advised that the existing premises will be occupied throughout the period of the contract, and that the minimum amount of disruption to services is of the utmost importance.

Damage to the existing buildings - Bidders to note that any damages done or occurring to any of the buildings will be repaired at the expense of the contractor/ Bidder.

The repairs must be to the satisfaction of the Kwazulu- Natal Department of Health. Bidders are advised to visit the site prior to tendering and to acquaint themselves with the nature of the work to be done and access to the siting of the existing buildings etc., as no claim whatsoever will be allowed on the grounds of ignorance of the conditions under which the work will be executed.

***NB: Bidders are advised to examine the drawings and visit the site prior to quoting and to acquaint themselves with the nature of the work to be done and access to the siting of the existing buildings etc., as no claim will be***

*allowed on the grounds of ignorance of the conditions under which the work will be executed.*

### **1.3.5 SATISFACTORY INSTALLATION**

The whole of the installation shall be carried out in accordance with the South African Bureau of Standards Code of Practice for the application of National Building Regulations, the KZNPA Standard Preambles to all Trades, the KZNPA General Electrical Specification, ICASA, Telecommunications regulations, the South African Bureau of Standards Code of Practice for the Wiring of Premises SABS 0142 and the Occupational Health and Safety Act and Regulations 85/1993 as amended.

Copies of the KZNPA Standard Preambles to all Trades and the KZNPA General Electrical Specification are available at the office of the Secretary for Health – KwaZulu-Natal and can be obtained on request.

PROVINCE OF KWAZULU-NATAL  
DEPARTMENT OF HEALTH

ZNQ --

KILMUN CLINIC- CONSTRUCTION WAITING AREA SHELTER FOR PATIENTS AT  
KILMUN CLINIC.

**TECHNICAL SPECIFICATIONS**

**2. TECHNICAL SPECIFICATION**

**2.1 GENERAL**

This TECHNICAL SPECIFICATION shall be read in conjunction with all other sections of the SPECIFICATION and cognisance shall be taken of the clauses relevant to this particular installation, whether any specific clauses are referred to or not.

**2.2 *Standard Preambles***

This is available from the department on request.

**2.3 *Health and Safety Specification***

Health and Safety Plan with Risk assessment schedule is to be compiled taking cognisance of the specific type of patient's that walk around the institution all day. All areas are to be protected at all times from patients falling in. All new and old materials are to be securely stored during construction to eliminate any person from rolling them around or playing inside them.

Grading: 1 GB and above

**CIDB COMPLIANCE**

**2.4 Amendments:** Functionality in different contracting strategies in line with regulations 4.3.3 of the CIDB regulations, where functionality is evaluated, at least three Persons who are fully conversant with the Technical aspects of the scope of works shall undertake such evaluation

ZNQ --

KILMUN CLINIC- CONSTRUCTION WAITING AREA SHELTER FOR PATIENTS AT  
KILMUN CLINIC.

3. SCOPE OF WORK

The work to be carried out under this contract includes the supply of all materials, and including all labour to carry out all electrical work and leaving in service condition to the satisfaction of the Secretary for Health: KwaZulu-Natal.

3.1. The work comprises of

3.2 Supply and install the following

a) Waiting area shelter.

**Note: All work to be re measured on Completion.**

ALTERATIONS

All Notes, Preambles, etc. applicable for the various trades in the Bills of Quantities, will apply equally to the trades in this Bill. Tenderers are advised to visit the site and satisfy themselves as to the nature and extent of the work to be done, and also to examine the condition of the existing building.

Tenderers are advised that all materials from the pulling down (except where described to be re-used or handed over to the Department) will become the property of the Contractor, and all these materials, together with all rubbish and debris, must be immediately carted away, and the site left clean and unencumbered. Materials, etc. which are described to be handed over to the Department are to be carefully dismantled where necessary, and neatly stacked where directed on site. Items described as removed shall be removed from site. Credit for the value of the materials from the pulling down may be allowed for on the Final Summary page.

Prior to the removal of any timbers from the site, they are to be inspected by the Government Entomologist as laid down in Section 32 of the Government Forest and Veld Conservation Act of 1941 (Act 13 of 1941) as amended. If any of the timbers are infested with wood destroying agencies, they are to be disposed of in the manner prescribed by the Government Entomologist.

The Contractor is to give ample notice to the Department and Local Authorities regarding any disconnections necessary prior to the removal or interruption of electric light or telephone cables, water and sanitary services, etc.

Tenderers are advised that adjacent sections of this building will be occupied during the building operations, and the Contractor is required to carry out the work with as little noise, dust and disturbance as possible. Undisturbed access is to be given to patients, staff and visitors.

The Contractor is advised to check all dimensions affecting the existing building as he will be held solely responsible for all new work being of the correct size. All sizes stated are approximate and under no circumstances will claims be entertained should actual sizes of existing items on site vary marginally from the sizes stated in this document.

The Contractor will be held solely responsible for any damage to persons, property, and equipment and for the safety of the structure throughout the whole of the Contract, and must make good at his own expense any damage that may occur.

The Contractor must obey the instructions of the Department in carrying out any portion of the work which in his opinion requires expediting, and the Contractor shall give priority to such work as and when directed.

In taking down and removing existing work, the utmost care is to be observed to avoid any structural or other damage to the remaining portions of the building. The Contractor must also protect all work not removed, such as walls, floors, doors, windows or joinery, loose and fixed fittings and electrical equipment, appliances, etc. from damage during the progress on the works and provide all necessary materials in so doing.

#### STANDARD PREAMBLES TO ALL TRADES 92

#### EARTHWORKS SITE CLEARANCE

The item given in the Bills of Quantities for site clearance shall be deemed to include the removal from the site, or burning if permitted by the Local Authority, of shrubs and trees with trunks under 200mm girth measured at 1m above ground level, STANDARD PREAMBLES TO ALL TRADES 3 Rev 3 January 2009 hedges, bushes, other vegetation, rubbish and debris. Holes left by roots are to be backfilled with earth and rammed. EXCAVATIONS: — Rates for excavations are to include for forming and trimming to the correct levels, falls, slopes, curves, etc. for trimming sides, stepping, levelling and ramming bottoms, staging and disposing of the excavated material as described in the items. Rates for excavations to reduce levels over site are also to include for forming and trimming banks to the required batter. The Contractor is to allow in his rates for the bulking of excavated material. The term "excavate", unless otherwise stated, shall mean excavate in "soft excavation" as defined below and for the purpose of classifying excavations the following will apply: — a) Soft excavation: — shall be excavation in material that can be efficiently removed by a back-acting excavator of flywheel power approximately 0, 10 kW per millimetre of tined-bucket width without the assistance of pneumatic tools such as paving breakers, or that can be efficiently loaded without prior ripping or stockpiling by a rubber tired front-end loader of approximately 15t mass and a flywheel power of approximately 100 kW. b) Intermediate excavation: — shall be excavation in material that requires a backacting excavator of flywheel power exceeding 0,10kW per millimetre of tined-bucket width and the assistance of pneumatic tools prior to removal by equipment equivalent to that specified in (a) above. c) Hard rock excavation: — shall be excavation in material that cannot be efficiently removed without blasting or without wedging and splitting prior to removal. d) Class A Boulder excavation: — shall be excavation in material containing more than 40% by volume of boulders of size between 0.03m<sup>3</sup> and 20m<sup>3</sup> in a matrix of softer material or smaller boulders. Note: — Excavation of solid boulders or lumps of size exceeding 20m<sup>3</sup> will be classed as hard rock excavation. (2) Excavation of fissured or fractured rock will not be classed as boulder excavation but as hard rock or intermediate excavation according to the nature of the material. e) Class B Boulder excavation: — shall be excavation of boulders only in a material containing 40% or less by volume of boulders of size between 0.03m<sup>3</sup> and 20m<sup>3</sup> in a matrix of softer material or smaller boulders. Note: — Those boulders requiring individual drilling and blasting in order to be loaded by a back-acting excavator as specified in (a) above, or by a track type frontend loader, will each be separately measured as Class B boulder excavation. The excavation of the rest of the material will be classed as soft or intermediate excavation



according to the nature of the material. Method of Classifying: —The Contractor may use any method he chooses to excavate any class of material but his chosen method of excavation shall not determine the classification of the excavation. The Department will decide on the classification of the materials. The classification will be based on inspection of the material to be excavated and the criteria given in (a) to (e) above, as applicable. The decision of the Department shall be, subject to the relevant provisions of the contract, final and binding. Should the Contractor consider that the excavation is other than "soft excavation" he must notify the Department immediately in order that an inspection be made and a decision arrived at by the Department as to the category of such excavation. Should the Contractor fail to give such notification, the excavation shall be deemed to be "soft excavation" and shall be measured and valued accordingly. Blasting will only be permitted with the written authority of the Department, if and when permission is granted, it is to be executed only by persons holding the necessary Government Blasting Certificate and subject to all regulations imposed by the Department and/or Local Authority. In addition, the Contractor is to indemnify the Provincial Administration against all claims in respect of damage to persons and property resulting from such blasting operations. STANDARD PREAMBLES TO ALL TRADES 4 Rev 3 January 2009 Before commencing any excavations, the Contractor must satisfy himself as to the accuracy of any levels indicated on the drawings, as no claim will be entertained at a later date for any alleged inaccuracy in such levels. Excavation shall be carried down to such depths as are necessary to obtain firm foundations, but before proceeding to greater depths than are shown on the drawings, the Department's approval must be obtained. The Contractor will be responsible if he excavates wider or deeper than shown or required. If the excavations are deeper than shown or required such extra excavations are to be filled in with mass concrete at the Contractor's expense. If the excavations are wider than shown or required, any form-work or mass concrete filling required to the side of the concrete foundations is to be executed at the Contractor's expense and to the approval of the Department. Depths of excavations as approved shall be checked and recorded by the a Departmental Official and the Contractor's Foreman before any concrete is laid or the excavations are otherwise covered or filled in. Notwithstanding such approval, any excavations which become waterlogged or otherwise spoilt after approval, shall be cleaned out and reformed, at the Contractor's expense and to the satisfaction of the Department, before any concrete, etc. is laid. WATER: — The Contractor shall keep all excavations free from water or mud by pumping, baling or otherwise. WORKING SPACE: — The Contractor is to allow against the items of "excavate to provide working space" for excavating beyond the extent of the net excavations measured to provide the necessary working space for the carrying out of such work as is described in the items. Rates are to include, in addition to the extra excavation, for any additional risk of collapse so incurred and for filling back and compacting the excavated material. No separate item for working space is provided or will be considered where the face of the measured excavation is 750mm or more away from the finished face of the structure. Separate items for working space for the building of brick foundation walls on ordinary concrete wall footings will not be considered. In the case of column base and pile cap excavations, where the dimensions between the column face and the excavation face is less than 500mm, working space has been measured for the width of the column face from the commencing level of excavation to the top of the column base or pile cap only where the top of the column base or pile cap exceeds 1.5m below the commencing level of excavation. RISK OF COLLAPSE: — The Contractor shall maintain all excavated faces affecting the safety of the works and workmen. He must either provide all necessary temporary planking, strutting or shoring to all vertical excavated faces or carry the risk of collapse of these faces with all its implications. He must assume full responsibility in this connection and must allow in his rates accordingly. In addition, all excavated faces exceeding 1.5m deep are to be maintained in accordance with Government Regulations. Quantities reflect the total superficial areas of the vertical excavated faces and will be subject to variation only in so far as these areas may vary, notwithstanding whether any temporary supports are used or not. FILLING, ETC.: — All backfilling and filling under floors and paving

must be of selected material from the excavations, unless otherwise stated, returned and compacted in layers as later described and with the top surface dressed to the correct levels and grades, all to the approval of the Department. Under no circumstances will the Contractor be allowed to use clay, peat or other unsuitable material for filling. STANDARD PREAMBLES TO ALL TRADES 5 Rev 3 January 2009 Rates for all items of filling with material from the excavations are to include haulage not exceeding 100m from the perimeter of the excavations. Any filling supplied by the Contractor is to be of suitable material approved by the Department. COMPACTION OF FILLING ETC.: — All filling and backfilling is to be done in layers not exceeding 200mm thick before compaction, with the layers level to ensure uniform compaction. Each layer is to be thoroughly compacted over the whole of the area to a dry density not less than 90% of Mod. A.A.S.H.O. density. The surface of each compacted layer shall be uniform and tightly bonded. Care is to be taken that no damage is done to foundation walls, drains and other services. The densities of compaction referred to are to be determined by tests carried out in accordance with A.S.T.M. Designation D 1557-58 and at an optimum moisture content of not more or less than 5% of the required Mod. A.A.S.H.O. The Contractor shall be responsible for having sufficient tests taken of the density of the compacted filling to ensure that the required compaction is being attained to the satisfaction of the Department. These tests are to be undertaken by an independent testing authority nominated by the Contractor to the approval of the Department. The costs of all tests in this connection shall be borne by the Contractor and shall be allowed for in his rates. PROTECTION AGAINST SUBTERRANEAN WOOD-DESTROYING TERMITES: — Where protection against termites is to be provided: — a) Remove vegetable matter All dead roots and other vegetable matter likely to encourage termites must be removed from the ground under, against the building and from all filling material. b) Treating the ground The ground under surface beds, and below suspended wood floors, must be treated by the application of Soil Insecticides of Chlordane or Aldrin types complying with SANS Specifications 1165 and 1164 respectively, mixed with water and applied at the rate of not less than 5 litres of solution per square metre uniformly over the whole surface. The concentration of the solution must be strictly in accordance with the manufacturer's instructions and to the approval of the Department. The Department reserves the right to take samples of the diluted solution, at any time, in order to test the concentration of the chemicals used. Where the ground to be treated is of earth filling, the upper 50mm layer of filling must be levelled by raking, but must not be rammed until after the solution has been applied, and where of natural ground, it must be loosened to a depth of not less than 50mm and similarly levelled, in order to enable the solution to penetrate into the soil. After the solution has been applied and allowed to penetrate the surface, the soil must be well rammed and consolidated. Before applying the solution to the ground under the floors, splay back earth for a depth and width of 75mm from the internal faces of walls enclosing the floors, against internal walls, sleeper piers, etc. and thoroughly saturate with the solution. After the solution has soaked into the earth, the splayed grooves must be filled with earth and consolidated. The treated layer of soil under suspended wood floors must be protected with a 75mm thick layer of approved clean gravel, finished to an even surface. The treated layer of soil under concrete surface beds must be protected with a 25mm thick layer of well-consolidated approved grit prior to laying the waterproofing membrane. Great care must be taken when laying concrete surface beds, protective layers, etc. in order to avoid rupturing the treated layer of soil. Should the treated layer be ruptured at any STANDARD PREAMBLES TO ALL TRADES 6 Rev 3 January 2009 point it must be made good and the area affected re-treated with the soil insecticide. Contractors are advised that: a. Special precautions must be taken to protect the workmen whilst using the soil insecticide. b. The treatment of filling or ground under floors shall be done as soon as practicable, so that treatment may dry out before the floors are laid. c. The treatment of the ground must be carried out under the supervision of the Department. d. The soil insecticide to be delivered to the site in sealed drums clearly labelled or stamped with the name of the product. e. In addition to the foregoing the application of the soil insecticide to be carried out in accordance with SANS Code of Practice 0124 — the application of Certain Soil

Insecticides for the Protection of Buildings. f. The protective layers of gravel or grit have been measured separately. RE-USE OF EXCAVATED MATERIAL: — Material of any kind that may be discovered on the site during the excavation shall remain the property of the Administration. Such material may, if approved, be used for aggregate. Material so used shall be valued and the value deducted from the Contract Sum. DEMOLITIONS: — The Contractor is referred to the preambles for "Alterations" insofar as they apply and the following: — The demolition of existing buildings is to be done in a practical and safe manner, under the continuous supervision of a competent Foreman. Rates for the demolition of existing buildings are to include for breaking up and removing all external screen walls, steps and ramps, surface water channels, rainwater sumps, gulleys, etc. and grubbing up and removing all foundation walls and footings, disconnecting and removing all services to a point not less than 1m beyond the perimeter of the buildings, plugging off ends of all remaining pipes, and for filling in all holes with clean earth and ramming up to ground level. All movable fittings and furniture, fire extinguishers and electrical and other equipment in the buildings to be demolished are to remain the property of and will be removed by the Administration prior to the commencement of the demolition. Before commencing the demolitions, the Contractor shall comply with any Local Authority regulations in force in respect of rodent extermination, etc. and he shall obtain the required Clearance Certificate. Items to cover the cost of obtaining the certificate and the fumigation, etc. of the buildings to be demolished have been provided elsewhere in the Bills of Quantities, and the fumigation is to be carried out by a firm specialising in this type of work. The fumigation of the buildings to be demolished shall only be carried out if called for by the Local Authorities and if not required the value of the relevant items in the Bills of Quantities will be deducted from the Contract Sum. After handing over the site to the Contractor, the risk of any loss or damage to the buildings to be demolished and the materials therein, caused by theft, vandalism, etc. shall be the responsibility of the Contractor and he shall take such precautions as he deems necessary against such loss or damage. GRASS PLANTING AND TURFING: — Is to be "Cape Kweek" or "Umgeni" grass scientifically known as *Cynodon dactylon* or other local fine grass approved by the Department. In areas where fine grass does not grow readily, Kikuyu grass *Pennisetum clandestinum* may be substituted. The areas must be identified and the approval of the Department obtained before Kikuyu grass is to be planted. Grass Planting To Level Areas: — The areas to receive grass are to be weeded and raked free of stones and other superfluous matter and all depressions left by the earthworks plant are to be filled in with approved topsoil. The planting of grass is to be carried out in continuous root planting in rows 200mm apart. The method of planting called "sprigging" may be used as an alternative. STANDARD PREAMBLES TO ALL TRADES 7 Rev 3 January 2009 Immediately after completion of each strip or square, the area thus grassed is to be thoroughly watered and lightly rolled. Any drifting or piling up of the top soil due to wind or any other cause must be prevented as far as possible and should such piling up of soil against newly planted grass occur the soil must immediately be raked level and lightly rolled. Turfing: — Banks are to be carefully trimmed to an even surface and weeded and raked free of stones, etc. and all depressions filled in with approved topsoil as before described. Turfing of banks is to be carried out with 25mm thick maximum 500mm x 1000mm weedfree grass sods, of grass as before described, and as approved by the Department. The grass sods are to be set in position in horizontal rows to broken bond and closely fitted together and tamped flat with a timber pummel, a maximum of two sods in every square metre of area covered being staked to the bank to maintain position, with and including one sharpened wood or bamboo skewer 250mm long and with all cavities between sods filled in with approved top soil and the whole area lightly top soil dressed on completion. Established Lawn: — The use of established lawn in pieces size approximately 500mm x 1000mm x 25mm thick in lieu of grass sods on banks will be permitted provided that the established lawn is supplied and laid by a firm experienced in this type of work and to the approval of the Department. The fitting, tamping, staking and top dressing must all be as described for turfing, except that one piece per square metre is required to be staked as described. Fertilizer: — An approved fertilizer of the following

types— Type 2:3:2 for grass planted levelled areas and Type 3:2:1 for turfed or established lawn covered banks is to be supplied and applied by the Contractor at the rate of 400 kg per hectare. In the case of grass planted levelled areas the fertilizer is to be applied either before or after grass planting and in the case of turfed or established lawn covered banks the fertilizer is to be applied after the sods or pieces have been laid. The fertilizer above described is to in addition to any fertilizer which may have been specified to be applied during either the operation of scarifying and grading the area to be grassed or the re-spreading of top soil. A sample of the existing topsoil or the topsoil to be re-spread is to be sent to an approved fertilizer manufacturer for testing and advice on the acid or alkaline content of the soil. The cost of this test is to be borne by the Contractor if this is not provided free by the fertilizer manufacturer. The requisite quantities of limestone ammonium nitrate for acidic soil or ammonium sulphate for alkaline soil as determined by the soil test will be supplied to the Contractor by the Department and the cost thereof is to be included in a Provisional Sum elsewhere in the Bills of Quantities. The application of this treatment is to be undertaken by the Contractor and his rates for grassing, etc. must include for same. Weed killer: — “Weed Master or Turf Master” or other approved weed killer is to be applied to the entire grassed or turfed areas at a rate of 4 litres mixed with 200 litres of water per hectare, this being equivalent to 40-45 millilitres mixed with 5 litres of water per fifty square metres. The solution is to be sprayed on with a suitable spraying apparatus to achieve an even distribution. Six to eight weeks later, the operation is to be repeated. The application of weed killer is not to take place during wet weather. Weather conditions should be such as to allow a minimum of two hours or absorption before the likelihood of rain. Watering and Rolling: — The entire turfed area is to be kept clear of weeds, lightly rolled and thoroughly watered throughout the period of the Contract and or at least three months from the time of acceptance of the grounds or until the grassing or turfing is well established if that is sooner, all to the satisfaction of the Department. In the absence of rain, the initial watering of grassed or turfed areas is to be carried out as follows: — STANDARD PREAMBLES TO ALL TRADES 8

#### **ROOF COVERINGS CONCRETE ROOFING TILES:**

Shall conform to SANS Specification 542. The tiles are to be of pattern and colour specified and is to be even in thickness, uniform in shape and colour and free from cracks and blemishes. The tiles are to be laid to “straight bond” in accordance with SANS Code of Practice 062 with vertical joints and bottom edges of each course ranging perfectly straight. Unless otherwise specified each tile in every third course, all tiles in eaves and ridge courses and tiles in every course on each side of hips and valleys shall be secured with copper clout headed nails driven into the battens or with approved non-corrodible tile clips and nails in accordance with the manufacturer’s instructions. Where nail holes in tiles have been cut off at hips, valleys, top edges, etc. new holes are to be drilled. All ridge and hip cappings are to be of the types specified and of colour to match the roofing tiles. The cappings are to be bedded, jointed, pointed and torched up over roofing tiles in 1:3 cement mortar tinted to match the tiles. Where cappings having butt jointed ends are specified, an approved damp proof course conforming to Type C of SANS Specification 952 is to be fixed under, laid over the roofing tiles in accordance with the manufacturer’s instructions. Barge cappings are to be of the types specified and of colour to match the roofing tiles. The barge capping tiles are, unless otherwise specified, to be bedded, jointed, pointed and touched up over roofing tiles in 1:3 cement mortar tinted to match the tiles with every tile drilled and secured with copper clout headed nails to timber barge boards or bearers (elsewhere measured). Concrete tiles to residential units in non hail area’s are permitted. “CHROMODEK” ROOFING SHEETS: - Shall be the secret fixed type, supplied with all fittings in full-length sheets in the profile and colour as specified. Sheets shall be a minimum of .58mm and maximum of .8mm thickness. When .58 thick sheets are used, purlin spacings shall be a maximum of 1.2mtrç and maximum 1.5mtrç for .8 thickness. Sheets shall leave the factory in the specified colour and any scratches etc., due to handling are to be ‘touched up’ on site after installation. All fixings,

valleys, cappings and securing clips shall be to manufacturers' recommendations and no variations shall be accepted without prior approval from the department. 0,58mm thick roof sheeting for purlins up to 1,2m spacing and 0,8mm thick roof sheeting for purlins exceeding 1,2m – 1,5m spacing. In area's up to 30Km from the coast, metal roof sheeting to be 0,58mm thick with special corrosion protection as supplied in " Global- Duro" roofing sheets. All other area's to be 0,58mm as "Global-Tech corrosion protection. 0,58mm "Klip Lock 700 " or "Craflock " and 0,8mm " Brownbuilt ". ( 0,8mm is recommended for high rainfall and snow fall area's due to deeper trough. )

**RATES:** — for roof coverings, are to include for all necessary half tiles at verges and for all square cutting and waste at verges, abutments, and top and bottom edges and to both sides of ridges. **STANDARD PREAMBLES TO ALL TRADES 30 Rev 3 January 2009** Rates for cappings, etc. are to include for all short lengths, cutting, waste and fitting at intersections. All measurements are nett. No allowances have been made for overlaps.

**CORRUGATED IRON ROOFING, CLADDING AND FITTINGS:** — are to be of an approved brand and are to be manufactured from galvanized steel sheets of the thickness specified after galvanising and having a galvanized coating of "Iscor Coating Designation Z275" for inland areas and 'Z600" for coastal areas as specified. Roofing, etc. shall be lapped one and a half corrugations at sides and 30mm at ends unless otherwise specified. Roofing, etc. shall be fixed to timber purlins, rails etc. with standard galvanized drive screws 65mm long and to steel purlins, etc. with 8mm galvanized hook bolts of the lengths stated. Each screw or bolt shall be fitted with one lead washer and one bituminous felt washer and shall be spaced not less than one screw or bolt to every alternate corrugation across the width at end laps and ends of sheets and at each intermediate purlin or rail. Rates for roofing, cladding and fittings are to include for: — a) Fixing as described. b) Bedding washers in an approved mastic sealing compound c) Coating projecting ends of hook bolts and nuts with bitumen after fixing d) All square notches, square cutting and waste, laps, fitting and drilling. All measurements are nett. No allowance has been made for laps.

**FLUTED STEEL ROOFING, CLADDING AND FITTINGS:** — are to be approved galvanized fluted steel sheets and fittings manufactured from galvanized steel sheets of the thickness specified after galvanising (a) Galvanized steel sheets and fittings: — are to be manufactured from galvanized steel having a galvanized coating of "Iscor Coating Designation Z275" for inland areas and of "Z600" for coastal areas as specified with the sheets having a plain galvanized finish and the fittings an embossed galvanized finish. Roofing, etc. shall be fixed to timber purlins, rails, etc. with standard drive crews of the lengths stated and to steel purlins, rails, etc. with 8mm galvanized hook bolts of the lengths stated. Each fixing screw or bolt shall be fitted with washers as recommended by the manufacturer of the roofing Vertical cladding shall be fixed with broad flutes externally - unless otherwise described - to timber rails with standard galvanized drive screws 50mm long and to steel rails with 6mm diameter x 25mm long galvanized sheet bolts. Each fixing screw or bolt shall be fitted with washers as recommended by the manufacturer of the cladding including drilling steel rails as necessary. (b) Baked enamel finished galvanized steel sheets and fittings: — are to be manufactured from un-passivated galvanized steel having a galvanized coating of "Iscor Coating Designation Z275" and finished where described in the items, with approved factory applied baked enamel finish of colours to be selected by the Department. Roofing, etc. shall be fixed to timber

## METALWORK

**PROPRIETARY MATERIALS:** — Where proprietary materials are specified, the materials used are to be of the type, specified or other approved by the Department.

**RATES:** — for all metalwork, unless otherwise stated, are to include for cutting to length, shaping, turning, threading, forging, fitting, assembling, riveting, welding, welded running joints, filing smooth, also for all screws and holes and hoisting and fixing in position. All screwed work is to have full threads

**ALUMINIUM AND ANODISED ALUMINIUM:** — is to be of the brand specified or other approved and of 6063-TF or equivalent quality and temper.

Aluminium bars and sections shall comply with the relevant clauses of SANS 1476, extruded tube and hollow sections with the relevant clauses of SANS 1474, and sheet and strips with the relevant clauses of SANS 1470. All alloys to be anodised are to be of anodising quality.

Aluminium is to be free from flaws, hammer and die markings or other imperfections. Anodising of aluminium is to be carried out in accordance with SANS Specification 999 by an approved process. The average anodic film thickness shall be 25 micrometer, and at no point should the anodic film thickness fall below 22 micrometer or be thicker than 30 micrometer.

to anodising, all surfaces are to be de-greased and cleaned, all irregularities removed and flushed off smooth and buffed where necessary.

All anodised aluminium must be coated with a suitable "non-yellowing" methacrylate lacquer film, approved by the Department, over the entire surface. The lacquer film must be continuous and of a uniform average thickness not less than 10 micrometer. The lacquer thickness must be determined by use of a film meter or other instrument methods as described in ASTM B244-49T. Rates for anodised aluminium must include for this protective coating.

Before the work is put in hand, samples of finish are to be submitted to the Department for approval, and all finished work is to be equal in all respects to the approved samples.

The Contractor shall provide all samples required for testing in accordance with SANS Specification 999. If required, tests on the anodic film are to be carried out at the works of the anodised to verify that the work conforms to SANS Specification 999, the cost of which will be borne by the Contractor.

The surfaces of all aluminium which are jointed to or are in contact with other materials when fixed, particularly ferrous metals, are to be suitably insulated to prevent electrolytic corrosion.

Joints in all aluminium members are to be neatly formed in an approved manner with screw heads, pins, rivets, etc. concealed so that the joints are practically invisible. Screw or bolt jointing is to be kept to a minimum and will be permitted only when welding is impracticable.

Unless otherwise described, stainless steel screws or bolts are to be used for jointing and fixing aluminium work. Welded joints are to be formed by argon arc process using SANS



1476/NS6 welding rods and finished off smooth.

Welding is to be executed in such a manner as not to affect the colour of the material or the anodic coating.

Exposed heads of screws, pins, rivets, etc. in coloured anodised aluminium are to be touched up with enamel paint to match the coloured anodised finish.

In the general construction and design affecting neatness, strength or durability may be introduced. If any deviation is proposed, the Contractor must submit detailed drawings showing the particular construction and form or section he proposes to use and such drawings, details and samples of fittings, etc. are to be approved by the Department before manufacture is commenced and every facility must be given for the work to be inspected during manufacture.

No work may be fixed in position until it has been inspected and approved. Anodised aluminium work must be erected as near to the end of the Contract period as possible, to minimise the danger of damage or deterioration.

All work is to be suitably protected during building operations and left in a clean and satisfactorily finished condition on completion. In particular, all anodised aluminium work must be protected against damage, and against deterioration or discolouration caused by mortar droppings, wax, paint, etc. all to the entire satisfaction of the Department. All work so damaged, deteriorated or discoloured must be replaced at the Contractor's expense.

Rates for aluminium work are to include for necessary cutting to lengths, shaping, turning, threading, forging, fitting, assembling, riveting, welding, welded running joints, filing smooth, also for all screws and holes and hoisting and fixing in position. All screwed work is to have full threads.

**ANODISED ALUMINIUM WELDED WINDOWS AND DOORS:** — are to be of an approved manufacture and design.

Windows and doors are to be fabricated from Medium Universal equal leg sections, unless otherwise specified, measuring 33mm over one opening section and not less than 4mm thick through the flanges and not less than 4.75mm through the web, unless otherwise stated.

The aluminium sections are to be of approved manufacture and of 6063-TF or equivalent quality and temper and are to be anodised after manufacture to the approval of the Department. Welds are to be electrically flash butt resistance welded, properly ground and cleaned off to give a uniform appearance.

Anodising, etc. is to be carried out as before described.

Windows and doors are to be suitable for internal glazing and are to be fitted with approved anodised aluminium glazing beads of the "clip on" type. Drilling for the fixing of glazing beads is to be done to suit the thickness of the glass used.

The frames are to be perfectly flat, square, butt-welded at joints (mechanical joints will not be permitted) and all opening sashes must fit perfectly on all faces and open or close freely without binding at any point. The glazing bars must be continuous with continuous intersections (mitred intersections will not be permitted) with ends scribed and fitted to the frames with shouldered ends passed through and riveted over. The sight lines of the main

frame, whether consisting of all fixed lights, all opening sashes or portions of both and the glass plane must be the same throughout each window.

Weathering on sections is to be solid extruded with the sections (screwed or riveted on strips will not be permitted) except weather bars to sills of inward opening sashes which must be welded on and not screwed or riveted except in the approved designs of built-up transoms.

No steel is to be used in the manufacture of the windows unless it is stainless steel of quality to A.I.S.I. Type 316. All fittings, butt hinges, screws, nuts, bolts, etc. are to be of high quality aluminium or other approved non-corrosive material compatible with aluminium and of sufficient strength to perform the functions for which they are used. The handles, sliding stays and peg stays are to have nylon washers, bushes and pressure pads and are to be secured to the frames with screws having riveted ends. Pop rivet fixings will not be permitted.

The transoms and mullions of all purpose-made windows and doors are to be equally spaced between the outer frames to form openings of equal size. Where this is not the case, either the width or the height of the opening is stated. Unless otherwise stated, the fixed lights and sashes of all purpose-made windows and doors are to be in one square and the sashes and doors are to open out.

Frames must be provided with suitable fixing lugs bolted on to frame with aluminium alloy bolts or are to be holed for screwing as required with lugs or holes spaced one near top, one near bottom and not more than 750mm apart intermediately each side of frame.

Frames more than 900mm wide are to be provided with similar fixings to top and bottom and not more than 750mm apart.

All composite windows, doors, etc. are to be supplied with suitable and approved coupling mullions or transoms. Rectangular hollow section transoms where specified are to be

25mm x 115mm in section manufactured from 3mm thick aluminium.

The Contractor must submit drawings showing details of sections he proposes to use and these drawings are to be approved by the Department before manufacture is commenced, and when requested, specimen windows and doors complete with all fittings as well as specimen coupling mullions, transoms etc. must be submitted for approval and all windows, doors, etc. supplied must conform to the approved samples.

manufacturer of the windows and doors must supply a dimensioned set of drawings with the windows and doors, for use on the site, including clearance and strict fixing methods and details.

Windows and doors are to be delivered to the site in suitable protective wrappings or crates and are to be stacked on end and carefully handled at all times to prevent any marking or staining of surfaces.

Immediately the windows and doors have been delivered on the site, they are to be thoroughly overhauled and all necessary adjustments or repairs are to be made before they are fixed in position. A further inspection is to be made after fixing and any further servicing required must be carried out in order to leave the windows and doors in a satisfactory condition and waterproof after glazing is completed.



**Side Hung Sashes:** — are to open out on a pair of aluminium hinges complete with antifriction weatherproof bushings fixed pin and nylon washers and fitted with anodised aluminium alloy sliding stay with friction fastener and an approved anodised aluminium two point handle and striking plate.

**Bottom Hung Sashes:** — are to open in on a pair of aluminium hinges complete with antifriction weatherproof bushings, fixed pin and nylon washers and fitted with concealed side arms and strong lever action spring catch and keep.

**Top Hung Sashes:** — are to open out on a pair of aluminium hinges complete with antifriction weather proof bushings, fixed pin and nylon washers and fitted with anodised aluminium peg stay with cranked locking stay.

**Pivot Hung Sashes:** — are to be hung on a pair of approved weatherproof brass satin-chrome finished friction pivots of the greatest possible diameter permissible and fitted at top with strong lever action spring catch for long arm or hand operation and striking plate, unless otherwise stated.

**Vertically Pivot Hung Sashes:** — are to be hung on free pivot cups at the head incorporating nylon bearing sleeves and lever pivots at the sill and fitted with one two-point casement handle and striking plate.

**Projected Out Sashes:** — are to be balanced on approved concealed side arms with stainless steel shoes and channels and fitted at bottom with one approved bow handle with catch incorporated.

**In Sashes:** — are to be balanced on approved concealed side arms with stainless steel shoes and channels and fitted at top with strong lever action spring catch for long arm or hand operation and striking plate:

**Doors:** — are to be side hung to open out on one and a half pairs of aluminium hinges to each leaf complete with anti-friction weatherproof bushings, fixed pin and nylon washers and fitted with lock set as specified, and each lock is to be provided with two keys. Satin chrome finish flush bolts are to be fitted at top and bottom of meeting edge of first closing leaf of double doors.

**Adjustable Louver Sets:** — are to be approved anodised aluminium adjustable louver sets consisting of head and all weather strips fitted with neoprene gaskets and two jamb strips

each fitted with louver brackets with spring loaded clips for the specified width of glass louver blades and complete with tilt bars and operating lever handles. Where the openings are not of height to suit standard width louver blades an alternate head section with static clips must be provided to take a fixed louver blade of the required width. The sets-sets are to be tap screwed to the window frame with stainless steel self-tapping screws.

#### **GLAZING TO DOORS / ALUMINIUM GLAZED SCREENS**

No glazing permitted to any fitting below Lock Rail ( ie 1,2m high. ).

**Burglar Bars:** — are to be standard type burglar bars formed of 20mm x 5mm aluminium bars riveted at intersections and riveted at ends to the window frame with high strength

aluminium rivets. The burglar bars to the small pane type window are to line through with the glazing bars, and windows of the horizontal-pane type or of the no-glazing bar type are to be fitted with burglar bars which are divided as for the small pane type window.

All exposed surfaces of anodised aluminium are to be protected by means of an approved fabric backed adhesive tape. The Contractor shall satisfy the Department that the tape he proposes to use can be easily stripped after long exposure to sunlight, and rates are to include or the final stripping of the protective tape and cleaning down to approval at completion.

All work is to be protected during building against deterioration or discolouration caused by mortar droppings, wax, paint, etc. and all work so damaged is to be replaced at the Contractor's expense to the approval of the Department.

All glass and glazing has been elsewhere measured. All sashes and openings, unless otherwise stated, are to be single panes without glazing bars.

All windows and doors must be fixed into preformed openings in the structure (the building in of windows and doors will not be pen fitted) and rates are to include for supplying necessary templates for forming the openings. Fixing in position of windows and doors has been measured separately. Sizes of windows and doors are given to the nearest 10mm.

**ADJUSTABLE LOUVER GEAR SETS:** — are to be approved natural anodised aluminium adjustable sets consisting of head and sill weather strips fitted with neoprene gaskets and two jamb strips and fitted with sets brackets with spring loaded clips for the specified glass sets blades and complete with tilt bars and operating handles. Where the openings are not of a height to suit standard width sets blades an alternate head section with static clips must be provided to take a fixed sets blade of the required width.

**RATES:** — are to include for fixing in accordance with the manufacturers instructions for screwing head and sill weather strips and jamb strips with stainless steel screws to frames (Elsewhere measured) and for oiling and easing at completion.

PROVINCE OF KWAZULU-NATAL  
DEPARTMENT OF HEALTH

ZNQ -

KILMUN CLINIC- CONSTRUCTION WAITING AREA SHELTER FOR PATIENTS AT  
KILMUN CLINIC.

SCHEDULE OF RATES

**4.1 ITEMS AND PRICING**

The Department reserves the right to place an order for any quantities of items included in the Schedules. The Schedule of Rates must also not be assumed to include and describe every detail of the supply requirement, but must be taken and read in conjunction with the other parts of the document. Thus the supplier shall not have claim for further payment in respect of any order which may be described or implied in the contract, although apparently no corresponding items are given in the Schedule of Rates. The supplier shall be deemed to have satisfied himself before quoting as to the correctness and sufficiency of his quote for the contract and of the rates and prices stated in the Schedule of Rates.

**4.2 TAX AND DUTIES**

Prices, quoted and paid, must include all customs, excise and import duties, and any other tariffs or taxes levied by the government or statutory body having jurisdiction on the goods provided under this contract, **including Value Added Tax (applicable to the current rate).**

**3.3 RATES**

Except where provision is made in the Schedule of Rates, the rates and prices inserted shall be the full rates and prices for the service delivered described under the respective items and shall cover all labour, transport, overhead charges and profit, etc. as well as the general liabilities, obligations and risks arising out of the Conditions of Contract, the overhead charges and profit being spread proportionately over the rates of the relative items in the Schedule of Rates.

Item No	Description	Qty	Rate	Amount
	<p style="text-align: center;"><u><b>BILL NO 1</b></u></p> <p><b>ALTERATIONS</b></p> <p>The Tenderer is referred to the relevant Clauses in the Model Preambles to All Trades and to the Supplementary Preambles which are incorporated at the back of these Bills of Quantities..</p> <p>Unless otherwise described the preambles and full descriptions of all items appearing in all the bills of the preceding sections are to apply equally to this section.</p> <p><b>NOTES</b></p> <p>The materials to be used and the work to be done are to be similar and equal to the new work Contained in all the subsequent Bills.</p> <p>Unless otherwise described, the preambles and full Descriptions of the items appearing in all the subsequent Bills are to apply equally to this Bill.</p> <p>Items described as to be re-used or to be handed over to the Director are to be carefully dismantled where necessary and stacked on site where directed, and the Contractor will be responsible for their removal and storage until required, and shall make good all items missing, damaged or broken at his own expense.</p> <p>Unless otherwise described, no materials from the alterations shall be re-used in any new work without the written approval of the Director, with the exception of facing bricks required in filling to openings, etc., which may be re-used if free of cracks and chips and properly cleaned of all mortar.</p>			
	Alterations			

Item No	Description	Qty	Rate	Amount
	<p>The Contractor is to take all dimensions affecting the existing buildings on the site as he will be solely responsible for all new work being to the correct sizes.</p> <p>Prices are to include for carting away from site all materials not specifically mentioned as being stored on site for re-use or handed over to the Director and all rubbish, debris, etc., arising from the alterations, etc., and for making good all work damaged or disturbed to the approval of the Director.</p> <p>Tenderers are to include in pricing for the statutory Requirements with regard to the demolition and disposal of asbestos cement material arising from the works.</p>			
	<i>Alterations</i>			

Item No	Description	Qty		Amount
<b>REMOVAL OF EXISTING WORK</b>				
1.	Taking down and removing steel square tubes including the concrete on the bottom of the poles which was used to secure the pole and make good.	Item		
2.	Remove existing all IBR sheeting's, capping, gutters etc. and make the wall good.	item		
3.	Remove existing road kerbs and make good	m	1.70	
<b>Carried to Final Summary Alterations</b>				R

Item No	Description	Qty	Rate	Amount
	<p style="text-align: center;"><b><u>BILL NO. 2</u></b></p> <p><b>EARTHWORKS</b></p> <p><b>(CPAP Work Group No. 104)</b></p> <p>The Contractor is advised that the term 'earth' includes natural ground and 'made-up' ground and he must allow in his prices for excavations for trenches, bases, etc., for excavation in natural ground and 'made-up' ground and for backfilling trenches, bases, etc., to reduced or natural ground level with the same material removed from below the reduced or natural ground level and backfilling over with the imported material used in filling under floors.</p> <p>No material from below the reduced or natural ground level is to be used in filling above the reduced or natural ground level and no imported material is to be used in filling below the reduced or natural ground level. Working Space</p> <p>The Contractor is to allow against the item of 'excavate to provide working space' for excavating beyond the extent of the nett excavations measured to provide the necessary working space for the carrying out of such work as described in the items. Rates are to include, in addition to the extra excavation, for any additional risk of collapse so incurred and for filling back and compacting The excavated material.</p> <p>Note the excavation include soft rocks, hard rock and stones etc.</p> <p><u>All hedges, bushes, other vegetation, rubbish and debris must be removed from the site to the dumping area; the site must be left unsoiled.</u></p> <p>Earthworks</p>			

Item No	Description	Qty	Rate	Amount
	<u>Prepare of ground to receive fresh concrete not exceeding 1.5 m deep (Drawing 3)</u>			
1.	North side ( 9 100 length X 300 mm wide )	m <sup>2</sup>	2.73	
2.	South side ( 9 300 length X1600mm wide)	m <sup>2</sup>	14.88	
3.	East side( 5 100 length X 850mm wide)	m <sup>2</sup>	4.34	
	<u>Excavation not exceeding 1.5 m deep to secure the square tube. Trench size 300mm length x 300 mm wide x 600mm deep (note there is 10 trenches).</u>			
4.	trench	m <sup>2</sup>	0.54	
	Carried to final summary Earthworks			R



Item No	Description	Qty	Rate	Amount
	<p style="text-align: center;"><b><u>BILL NO. 3</u></b></p> <p><b>CONCRETE, FORMWORK AND REINFORCEMENT</b></p> <p>The Tenderer is referred to the relevant Clauses in the Model Preambles to All Trades and to the Supplementary Preambles which are incorporated at the back of these Bills of Quantities.</p> <p><b>VIBRATED REINFORCED CONCRETE CAST ON/IN FORMWORK – 20 mPa / 19 mm concrete stones</b></p> <p><b>All concrete is to be effectively cured.</b> Footings and bases are to be kept wet for 7 days. Columns are to be wrapped in plastic for 7 days. Slabs are to be covered with plastic for 7 days</p> <p>Supply, deliver and cast concrete:</p> <p><u>Around the existing concrete slab,</u></p> <p><u>North side (9 100 length X 300 mm wide X100mm thick)</u></p> <p><u>South side ( 9 300 length X1600mm wide X 100mm thick)</u></p> <p><u>East side ( 5 100 length X 850mm wide X 100mm thick)</u></p>			
3.	Concrete	m <sup>3</sup>	2.20	
	<p>To secure the square tubes (10 tubes to be secured, trench size 300 x300 x600 mm deep )</p>			
4.	Concrete for poles	m <sup>3</sup>	0.54	
	<p><b>Carried to collection</b> Concrete, Formwork and Reinforcement</p>			

Item No	Description	Qty	Rate	Am
5.	<p><b>Supply, deliver and install:</b></p> <p><b>12 mm TAL SCREEDMASTER</b></p> <ul style="list-style-type: none"> <li>• Ambient temperatures between 10°C - 30°C must be maintained throughout installation and curing.</li> <li>• The Floor Slab must have a minimum temperature of 10°C during the SCREEDMASTER application.</li> <li>• The temperature of the water must be between 15 - 25°C when mixed with SCREEDMASTER.</li> <li>• Low floor slab and/or ambient temperatures and water temperatures will have a detrimental effect on the curing of the TAL SCREEDMASTER, ie full cure will never be achieved.</li> <li>• All "lows" and voids in the floor must be identified and cleaned out, and must be filled with TAL Rapidfix prior to applying TAL Screedmaster, and all "highs" or trowel marks must be identified and ground down. All defective areas of concrete/screed must be removed and made good using TAL Rapidfix.</li> <li>• Use electric drill (of at least 1.1 Kilowatts) to mix the Screed master, with clean water at suitable temperature.</li> <li>• Allow the screed installation to dry for 24 hours before subjecting to foot traffic (or other trades) or installing floor coverings</li> <li>• Area to be covered with screed master is 9 950 X 5 900</li> </ul> <p>On the floor</p>	m <sup>2</sup>	58.71	
	<p><b>Carried to collection</b></p> <p>Concrete, Formwork and Reinforcement</p>			

Item No	Description	Qty	Rate	Am
	<p><b>CONCRETE, FORMWORK AND REINFORCEMENT</b></p> <p><b>CONCRETE, FORMWORK AND REINFORCEMENT (CPAP WORK GROUP NO. 110 UNLESS OTHERWISE STATED)</b></p> <p>The Tenderer is referred to the relevant clauses in the Specification of Materials and Methods to be used PW371, the Supplementary Preambles and Notes.</p> <p><b>SUPPLEMENTARY PREAMBLES</b></p> <p><b>Formwork</b></p> <p>Descriptions of formwork shall be deemed to include use and waste only (except where described as "left in" or "permanent"), for fitting together in the required forms, wedging, plumbing and fixing to true angles and surfaces as necessary to ensure easy release during stripping and for reconditioning as necessary before re-use The vertical strutting shall be carried down to such construction as is sufficiently strong to afford the required support without damage and shall remain in position until the newly constructed work is able to support itself</p> <p>Allow for the for work to support concrete around the existing concrete slab</p>			
1.	North side ( 9 700 length X 100 mm wide )	m <sup>2</sup>	0.97	
	<b>Carried to collection</b>			
	Concrete, Formwork and Reinforcement			



Item No	Description	Qty		Amount
	<b><u>BILL NO.4</u></b>			
	<b>ROOF COVERINGS, ETC.</b>			
	<b>PREAMBLES</b>			
	For Preambles refer to "Standard Preambles to all trades -WB20 - 1986"			
	<b>SUPPLEMENTARY PREAMBLES</b>			
	Ridge coverings and flashings shall have at least 225mm laps and closers shall have at least 150mm laps at end joints with sufficient laps at angles and intersections.			
	Roof coverings, ridge coverings, closers, flashings, etc. are measured net and prices are to include for all laps, screws, bolts, etc. Prices for roof coverings are also to include for straight cutting. All work shall be left completely watertight.			
	<b><u>Supply, deliver and install:</u></b>			
	<b>PROFILED ROOF SHEETING</b>			
	<b>FIXING</b>			
	Fixing shall be done according to SABS 1200HB with minimum 225mm end laps			
	<i><u>Roof sheeting to be Green Klip-Lok 700 x 0,58mm thick heavy industrial Z275 spelter galvanised steel sheeting with Global coat Grey other side and accessories fixed to steel channels at 1200mm maximum spacing</u></i>			
	Area to be covered is: 9 100 x 4 450mm			
1.	Roof covering with pitch not exceeding 25°	m <sup>2</sup>	40.5	
2.	Barge flashing ( capping) 150mm 150 x 0.58	m	09.	
	Carried to final Summary ROOF COVERINGS, ETC.			R

Item No	Description	Qty	Rate	Amot
1.	<p style="text-align: center;"><u><b>BILL NO. 5</b></u></p> <p><b>FLOOR COVERING</b></p> <p><b>(CPAP WORK GROUP NO. 130 UNLESS OTHERWISE STATED)</b></p> <p>The Tenderer is referred to the relevant clauses in the Specification of Materials and Methods to be used PW371, the Supplementary Preambles and Notes.</p> <p>Note the vinyl has to done cover the floor and entrance wall,</p> <p>Supply, deliver and install 2.5 mm vinyl floor sheeting with welded joints colour Tanzanite blue.</p> <p><b>Carried to final summary</b> Floor covering</p>	m <sup>2</sup> 40.		

Item No	Description	Qty	Rate	Am
	<b><u>BILL NO.6</u></b>			
	<b>IRONMONGERY: (CPAP WORK GROUP NO. 132 UNLESS OTHERWISE STATED)</b>			
	The Tenderer is referred to the relevant clauses in the Specification of Materials and Methods to be used PW371, the Supplementary Preambles and Notes.			
	<b>SUPPLEMENTARY PREAMBLES</b>			
	<b>Finishes to ironmongery</b>			
	Where applicable finishes to ironmongery are indicated by suffixes in accordance with the following list:			
	BS Satin bronze lacquered CH Chromium plated			
	SC Satin chromium plated			
	SE Silver enamelled			
	GE Grey enamelled			
	AS Anodised silver			
	AB Anodised bronze			
	AG Anodised gold			
	ABL Anodised black			
	PB Polished brass			
	PL Polished and lacquered			
	PT Epoxy coated			
	SD Sanded			
	<b>HINGES, FLOOR SPRING HINGES, BOLTS, PANIC BOLTS, ETC.</b>			
	Supply, deliver and install:			
1.	<b>Motice latch and bolt narrow style</b> for aluminium door	no.	03.	
2.	<b>Aluminium flush bolts</b> for aluminium double doors (two per door, one on top and one on the bottom)	no.	02.	
	<b>Carried to final summary</b>			
	Ironmongery			

Item No	Description	Qty	Rate	Amou
	<b><u>BILL NO. 7</u></b>			
	<b>Structural steel work</b>			
	(CPAP WORK GROUP NO. 136 UNLESS OTHERWISE STATED)			
	The Tenderer is referred to the relevant clauses in the Specification of Materials and Methods to be used PW371, the Supplementary Preambles and Notes.			
	NOTES:			
	<u>Hot dip Galvanizing to be in accordance with SABS 7</u>			
1.	Supply, deliver and install Hot dip galvanized:	no.	05.	
2.	Square tube 75 x 75 x 1.60 mm with the welded base plate length of the square tube is 3 330 mm ( <b>North Elevation</b> ).	no.	05.	
3.	Square tube 75 x 75 x 1.60 mm with the welded base plate length of the square tube is 3 000 mm ( <b>South elevation</b> ).	no	05	
4.	Square tube 75 x 75 x 1.60 mm with the welded base plate length of the square tube is 3 200 mm ( <b>Rafters</b> )	no.	05.	
5.	<b>Galvanized Steel purlins</b> (channel) with the length of 9 100 mm ( check the attached drawing) <b>Drawing 1</b>	no.	04.	
6.	<b>Base plate</b> details: 300 x 300 x 10 mm check the attached drawing ( <b>Drawing 2</b> )	no.	10.	
	<b>Carried to final summary</b> Structural steel work			



Item No	Description	Qty	Rate	Amount
	<p style="text-align: center;"><b><u>BILL NO. 8</u></b></p> <p><b>METAL WORK</b></p> <p><b>ALUMINIUM WINDOWS, DOORS, SCREENS, ETC.</b></p> <p>Aluminium Windows</p> <p>Aluminium windows are to be manufactured and supplied by Messrs. Sheer line Systems or other approved institution.</p> <p>Windows are to be factory-glazed and fitted with all necessary PVC or neoprene glazing gaskets, aluminium glazing beads, weather seals, etc., in accordance with the manufacturers standard details.</p> <p>After fabrication the windows, glazing beads, etc., are to be properly etched and anodised bronze with an anodised film thickness of 25 microns in accordance with SABS 999.</p> <p>The frames are to be formed perfectly flat on all faces, truly square and properly jointed at angles and Intersections.</p> <p>The sight lines are to be the same throughout each Window of the same type.</p> <p>All frames are to be fitted with standard fixing lugs spaced one near each corner and not exceeding 450mm apart intermediately all round frame.</p> <p>The windows are to be protected with plastic sheeting held in position with non-staining adhesive tape capable of easy stripping.</p> <p>Prices for windows are to include for assembling the Component parts, setting up in position and plugging and screwing fixing lugs to concrete, oiling and easing all opening sections, protecting from damage and cleaning down and leaving in perfect condition at completion.</p> <p>Metal work</p>			

Item No	Description	Qty	Rate	Amount
<u>'Sheer line System 30' natural anodised aluminium windows glazed as scheduled and factory fitted with burglar bars to all opening sections: ( Drawing 4)</u>				
1.	Window in six top hung opening lights and six fixed Bottom lights 2 181 x 2 575mm high fitted with 4mm 'Armour plate' six top hung clear bottom lights obscure glass ( <b>Front</b> ).	no.	04.	
2.	Window in six top hung opening lights and six fixed Bottom lights 2 181 x 2 905mm high fitted with 4mm 'Armour plate' six top hung clear bottom lights obscure glass ( <b>Back</b> ).	no.	04	
3.	Window in six top hung opening lights and six fixed Bottom lights 3 850 x 2 575mm high fitted with 4mm 'Armour plate' six top hung clear bottom lights obscure glass ( <b>Sides</b> ).	no.	04	
4.	Windows on the triangle (all fixed). Triangle size is 3 850 base x 300mm perpendicular height fitted with 4mm 'Armour plate' clear glass ( <b>Triangles</b> ).	no.	2	
8.	Aluminium double door 1626 wide x 2032mm high fitted with 4mm 'Armour plate' clear top half and obscure bottom glass.	no.	02.	
9.	Aluminium single door 813 mm wide x 2032 mm high fitted with 4mm 'Armour plate' clear top half and obscure bottom glass.	no.	01.	
<b>Carried to Summary</b> Metal work				

Item No	Description	Qty	Rate	Amount
	<p><b><u>Metal work ( Aluminium)</u></b></p> <p>The Tenderer is referred to the relevant clauses in the Specification of Materials and Methods to be used PW371, the Supplementary</p> <p>Preambles and Note: The thickness of gutters and down pipes is 0.6mm. Colour green.</p> <p><b>Specifications:</b></p> <ul style="list-style-type: none"> <li>• Aluminium alloy 0.9 mm</li> <li>• Colour Green .</li> <li>• Downpipes aluminium required, rectangular shape 100 x 75 mm</li> </ul> <p>Install two downpipes</p> <p>Industrial 155 mm box gutter with following specifications: back height 100 mm, front height 125mm mm and bottom is 100 mm total length required is 26.30 m.</p> <p>Supply, deliver and install industrial 155 mm box gutter (note the building is divided into three sections, section A is 13 500 mm, section B is 2 300 mm and section C is 10 500 mm) total length of the building is 26 300 mm</p> <p>Supply, deliver and install Green Rectangular shape downpipes 100x75x0.6mm</p> <p>Carried to summary Metal work (Aluminium)</p>			
1.		m	9.10	
2.		m	4.80	

Item No	Description	Page No	Amount
	<p style="text-align: center;"><b>METAL WORK</b></p> <p style="text-align: center;"><b><u>COLLECTION SUMMARY</u></b></p>	<p style="text-align: center;">31.</p> <p style="text-align: center;">32.</p>	
	<p><b>CARRIED TO QUOTATION FORM</b></p>		

Item No	Description	Page No	Amount
<u>Final summary</u>			
1.	Alterations.	26.	
2.	Earthworks.	29.	
3.	Concrete formwork and Reinforcement.	30.	
4.	Roof covering.	31.	
5.	Floor covering.	34.	
6.	Ironmongery	35.	
7.	Structural steel work.	36.	
Less Material recovered onsite		-R	

The following documents must be returned with the quotation:

- CIDB Registration certificate under General Building
- Valid Tax Clearance

COMPILED BY: C.B. Ngcobo *C. Ngcobo*  
 CHIEF WORKS INSPECTOR AT HARRY GWALA HEALTH DISTRICT

CHECKED BY: B.J ZINDELA *B. Zindela*  
 DISTRICT ENGINEER AT HARRY GWALA HEALTH DISTRICT

# KILMUN CLINIC

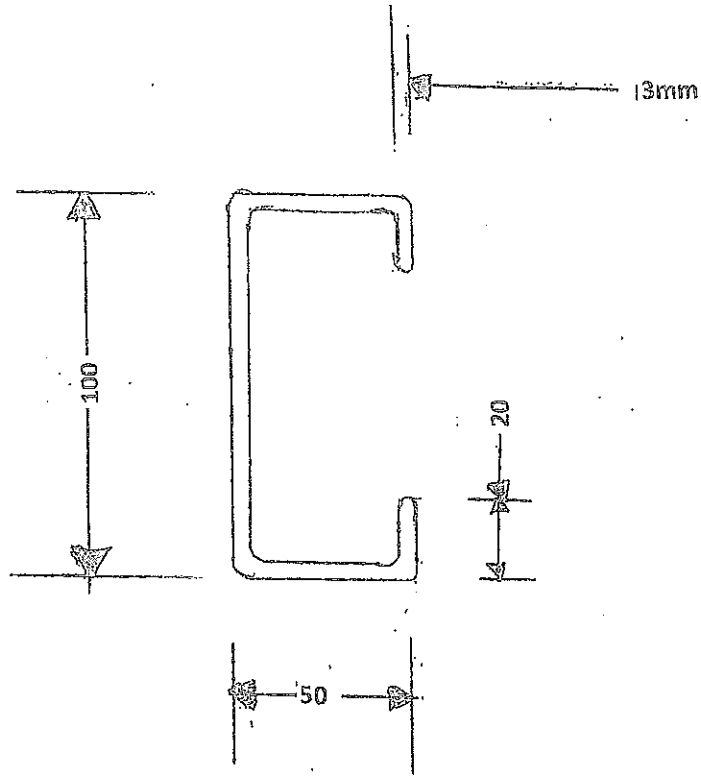

Lipped channel

Drawing 1

# KILMUN CLINIC

## Hop dipped galvanized base plate

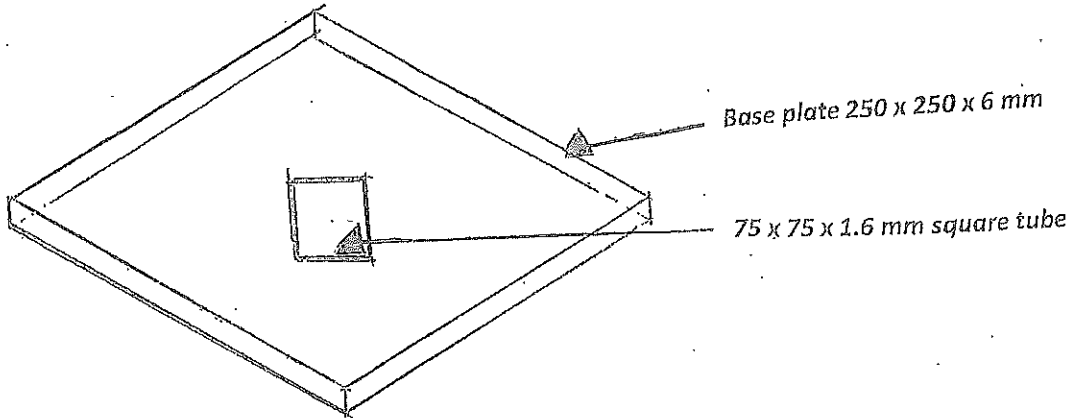

Drawing 2

North Direction

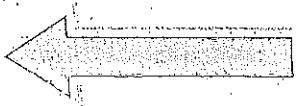

PARK HOME

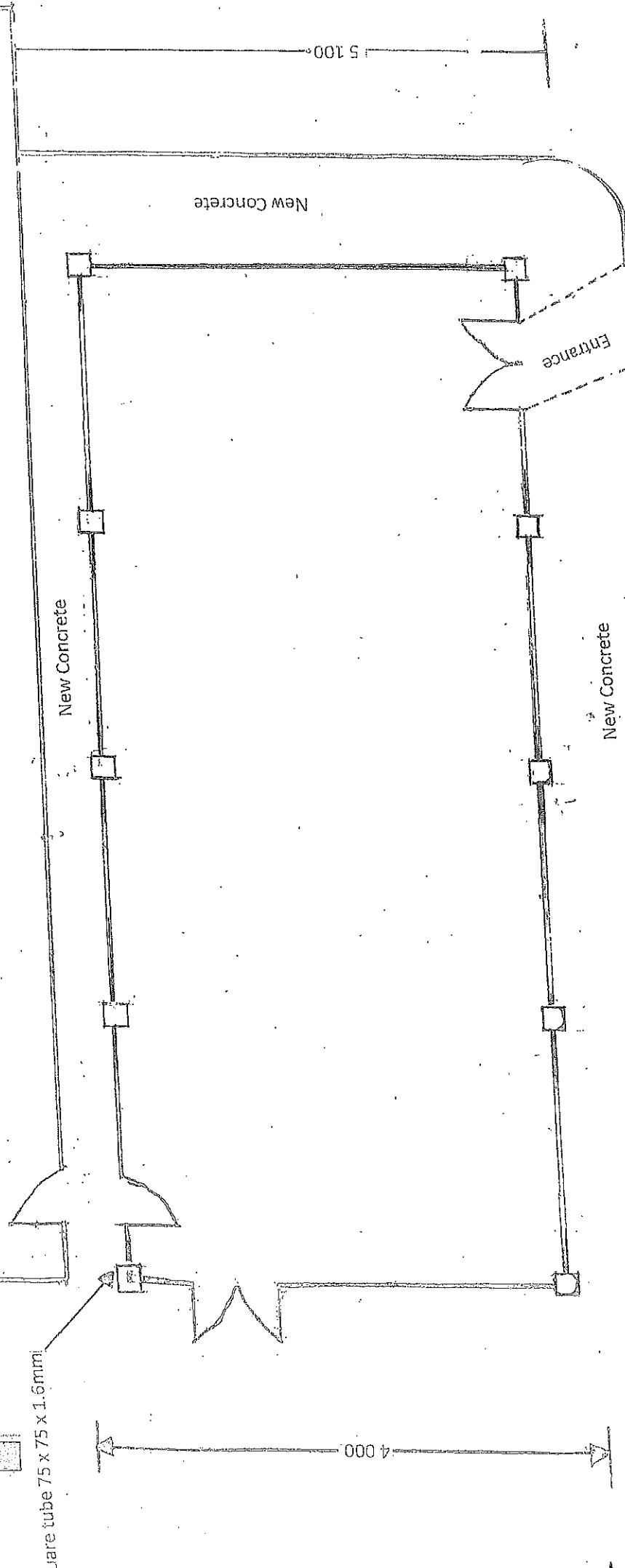

quare tube 75 x 75 x 1.6mm

New Concrete

New Concrete

Entrance

New Concrete

4,000

5,100

parking

9,100

Drawing 3



# KILMUN CLINIC

## DRAWING 4

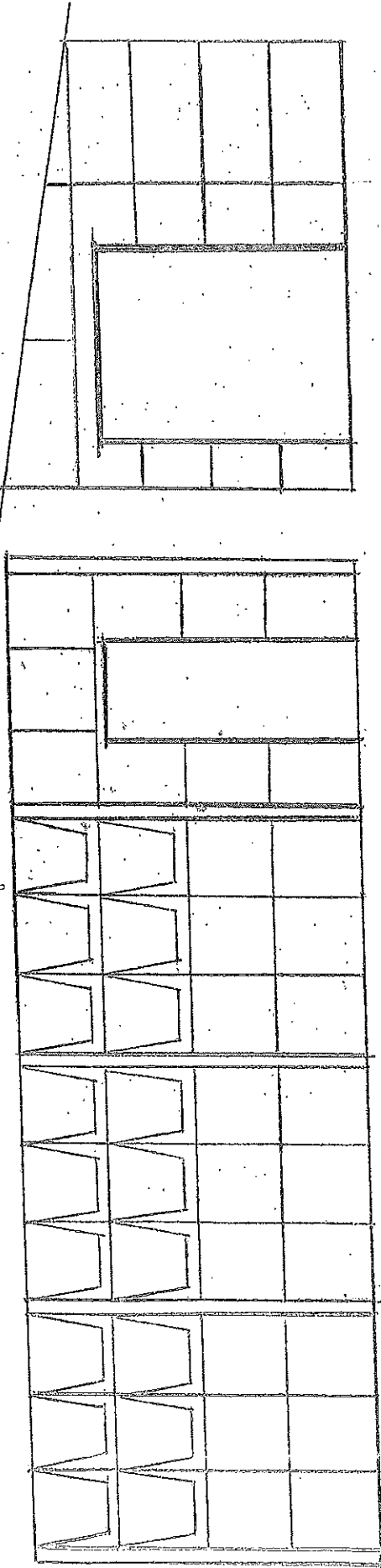

West elevation

North elevation

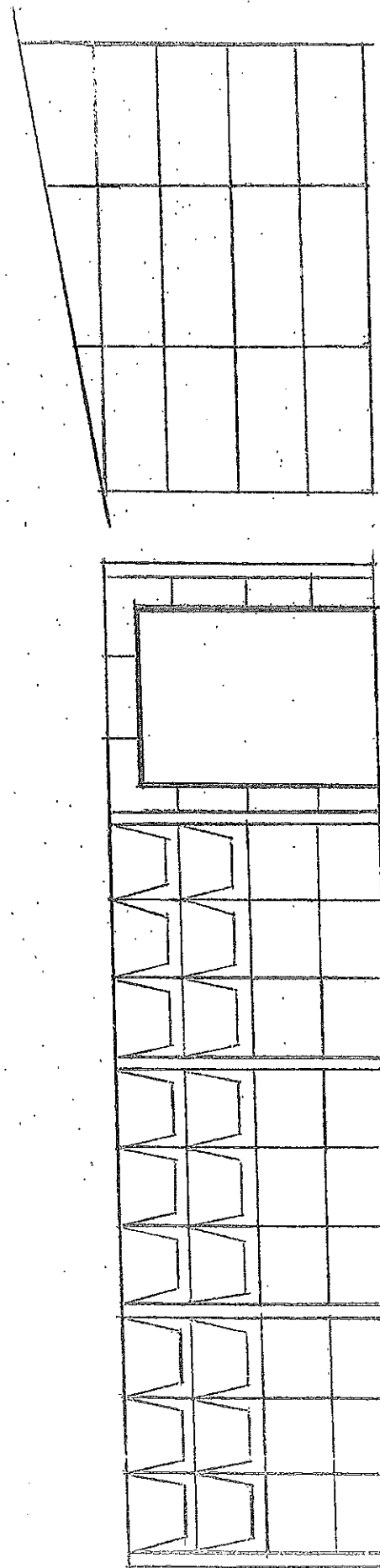

East elevation

South elevation

**PORTANT**

**THIS FORM IS ONLY TO BE INCLUDED AND COMPLETED WHEN APPLICABLE TO THE QUOTATION.**

**OFFICIAL BRIEFING SESSION / SITE INSPECTION CERTIFICATE**

Site/building/institution involved: **KILMUN CLINIC.**

Quotation No.: **ZNQ -**

Service: **CONSTRUCTION WAITING AREA SHELTER FOR PATIENTS AT KILMUN CLINIC.**

R

\*\*\*\*\*

THIS IS TO CERTIFY THAT..... OF (STATE NAME OF TENDERER) ..... VISITED AND INSPECTED THE SITE ON ..... (DATE) AND IS THEREFORE FAMILIAR WITH THE CIRCUMSTANCES AND THE SCOPE OF THE SERVICE TO BE RENDERED.

.....  
**SIGNATURE OF TENDERER OR AUTHORISED REPRESENTATIVE**

**DATE** : .....

.....  
**SIGNATURE OF DEPARTMENTAL REPRESENTATIVE**

**DEPARTMENTAL STAMP:**

**DATE** : .....



**health**

Department:  
Health  
PROVINCE OF KWAZULU-NATAL

St. Apollinaris hospital  
Off Centocow main road, Centocow, CREIGHTON, 3263  
Private Bag 206, Creighton, 3263  
Tel.: 039 833 8085, Fax.: 039 833 8054  
Email.: mpe.malinga@kznhealth.gov.za  
www.kznhealth.gov.za

SUPPLY CHAIN MANAGEMENT

Date: 12 August 2020  
ZNQ Number: 132/2020/1024

**TERMS OF REFERENCE**

**ITEM SPECIFICATION: Service Provider to do Construction of Waiting Area shelter for Patients at Kilmun Clinic, the shelter to withstand all kinds of weather (rain, cold and sun) as per attached specification.**

The kilometers from St. Apollinaris to Kilmun Clinic are+ 50 Kilometres return

Name & Surname	Designation	Signature
C.S.MBANJWA	SMO	
N.N.SOMHLAHLA	AMN	
N.NTOYAKHE	INFECTION CONTROL	
M.V.MATHANDA	SCC	

**SPECIFICATION TERMS AND CONDITIONS**

- Only bidders that fully meet the specification shall be considered
- The institution is under no obligation to accept the lowest or any quote
- The quality of products must be SABS / SANS/ CKS approved and a certificate of compliance must be submitted when required
- The bidder must ensure the correctness and validity quote: the prices, rates & preference quoted cover all of the work and accept that any mistake regarding with the price calculations will be at the bidder's risk
- If the information supplied is found to be incorrect or false then the KZN department of Health, in addition to the remedies it may have, may recover from the contractor all cost, losses and damages incurred by the department as a result of the award of the contract, and / or cancel the contract and claim any damages
- Defaulting suppliers in terms of delivering, will be dealt with and will be reported at Treasury
- The evaluation criteria for the quotation above R30 000 will be 80/20 for the price and points certified BBBEE certificates and original tax clearance
- Incomplete declaration of interest and quotation form will not be considered
- Orders will be cancelled if the supplier fail to meet the set standards and lead time
- All quotations requiring registration with certain Bodies must be returned together with the following:
  - Valid tax clearance
  - Proof of registration with CSD
  - CK certificate / Cipro certificate
  - CIDB registration and grading with relevant job category
  - Reference letter (from where the supplier did the same job successfully)
  - Letter of good standing
  - Current proof of registration with relevant bodies
  - Sworn statement
- All conditions indicated in the quotation form will be applicable upon evaluation, and should be attached to evaluation criteria
- Quotation form must be completed and signed in full, any omissions or incomplete information and signatures will automatically disqualify the quotation
- Bill of quantity should be fully completed and all segments must be filled per item
- A guarantee / warrantee must be provided on appliances, services and repairs
- All these conditions are binding and service providers must complied with
- Samples must be provided with documents unless indicated otherwise
- For services requiring site inspection , no late bidders will be allowed to join briefing
- It is advisable to get all necessary information before quotation closing date

Chairperson  
12/08/2020  
Date

End user  
13/08/2020  
Date

CEO  
19/08/2020  
Date