



Quotation Advert

Opening Date: 2020-10-15

Closing Date: 2020-10-23

Closing Time: 11:00

INSTITUTION DETAILS

Institution Name: Ilembe district office

Province: KwaZulu-Natal

Department or Entity: Department of Health

Division or section: Central Supply Chain Management

Place where goods / services is required ILEMBE EMS

Date Submitted 2020-10-14

ITEM CATEGORY AND DETAILS

Quotation Number: ZNQ:
191/20/21

Item Category: Goods

Item Description: SUPPLY AND DELIVER BUNNY JACKETS - MEDICAL GREEN AS PER SPECIFICATION x 160 UNITS

NB: BIDDERS ARE ENCOURAGED TO DEPOSIT QUOTATION DOCUMENT IN THE TENDER BOX, LOCATED AT GROUND FLOOR

Quantity (if supplies) 160 UNITS

COMPULSORY BRIEFING SESSION / SITE VISIT

Select Type: Not Applicable

Date :

Time:

Venue:

QUOTES CAN BE COLLECTED FROM: ATTACHED WITH TO THIS ADVERT OR COLLECTED AT ILEMBE HEALTH DISTRICT OFFICE (KWADUKUZA)

QUOTES SHOULD BE DELIVERED TO: TENDER BOX AT , NO.1 KING SHAKA STREET , KWADUKUZA (STANGER) GROUND FLOOR

ENQUIRIES REGARDING THE ADVERT MAY BE DIRECTED TO:

Name: S.N.MASUKU/ S.Z.ZULU

Email: nkululeko.nxasana@kznhealth.gov.za

Contact Number: 032 437 3500

Finance Manager Name: HLENGIWE NGCOBO

Finance Manager Signature:

No late quotes will be considered



health

Department:
Health
PROVINCE OF KWAZULU-NATAL

ZNQ191/20/21

ILEMBE HEALTH DISTRICT OFFICE

Supply & Deliver Bunny Jackets – Medical Green as per specification X 160 units

Advert Date : 15 October 2020
Closing Date & Time : 23 October 2020 @ 11h00
Contract Period : N/A
Administration Enquiries : Mr. S. N. Masuku /Mrs. S. Z. Zulu
Contact Number : 032 437 3500 Ext (3561/3562)

Technical Contact Person : N/A
Contact Number : N/A

DOCUMENTS MUST BE DELIVERED BY HAND AND DEPOSITED IN THE QUOTATION BOX SITUATED IN:

Lembe Health District Office
3rd Floor, King Shaka Center
1 on King Shaka street
KwaDukuza
"Next to Elevators"

THE QUOTATION BOX IS AVAILABLE ON THE FOLLOWING DAYS AND TIMES: MONDAYS TO FRIDAYS 07:30 - 16:00

COMPANY NAME : _____

OFFICIAL PRICE PAGE FOR QUOTATIONS

ZNQ NUMBER: **ZNQ191/20/21**

DESCRIPTION: **Supply & Deliver Bunny Jackets - Medical Green as per attached specification X 160 units**

SIGNATURE OF BIDDER DATE.....
 [By signing this document I hereby agree to all terms and conditions]

CAPACITY UNDER WHICH THIS QUOTE IS SIGNED.....

Item No	Quantity	Description	Brand & model	Country of manufacture	Price	
					R	c
1.	160 units	Supply & Deliver Bunny Jackets - Medical Green as per attached specification				
		Size: X Small X 1 unit				
		Size : Small X 17 Units				
		Size : Medium X 54 Units				
		Size Large X 62 Units				
		Size: X large X 17 Units				
		Size : XXL X 8 units				
		Size : XXXL X 1 Unit				
		NB: With department of health EMS Logos				
		NB:Attachments				
		1. CSD Suppliers Details				
		2.Certified Copy of BBBEE Certificate approved				
		by SANAS (or) EME Sworn Affidavit				
		NB: Attached Clear Colour Picture Item				
		(showing front and back)				
		NB: Actual sample may be requested				
VALUE ADDED TAX @ 15% (Only if VAT Vendor)						
TOTAL QUOTATION PRICE (VALIDITY PERIOD 60 Days)						

Does This Offer Comply With The Specification?	Does The Article Conform To The S.A.N.S. / S.A.B.S. Specification?
Is The Price Firm?	State Delivery Period E.G. E.G. 1day, 1week

<p>Enquiries regarding the quote may be directed to:</p> <p>Contact Person: S.N.Masuku Tel: 0324373500.....</p> <p>E-Mail Address:</p>	<p>Enquiries regarding technical information may be directed to:</p> <p>Contact Person: Tel:.....</p>
---	--

DECLARATION OF INTEREST

1. Any legal person, including persons employed by the state¹, or persons having a kinship with persons employed by the state, including a blood relationship, may make an offer or offers in terms of this invitation to quote (includes a price quotation, advertised competitive quote, limited quote or proposal). In view of possible allegations of favouritism, should the resulting quote, or part thereof, be awarded to persons employed by the state, or to persons connected with or related to them, it is required that the bidder or his/her authorised representative declare his/her position in relation to the evaluating/adjudicating authority where-
 - the bidder is employed by the state; and/or
 - the legal person on whose behalf the bidding document is signed, has a relationship with persons/a person who are/is involved in the evaluation and or adjudication of the quote(s), or where it is known that such a relationship exists between the person or persons for or on whose behalf the declarant acts and persons who are involved with the evaluation and or adjudication of the quote.

2. In order to give effect to the above, the following questionnaire must be completed and submitted with the quote.

- | | |
|---|---|
| 2.1. Full Name of bidder/representative..... | 2.4. Company Registration Number: |
| 2.2. Identity Number: | 2.5. Tax Reference Number: |
| 2.3. Position occupied in the Company (director, trustee, shareholder?):..... | 2.6. VAT Registration Number: |

2.7. The names of all directors / trustees / shareholders / members, their individual identity numbers, tax reference numbers and, if applicable, employee / persal numbers must be indicated in paragraph 3 below. [TICK APPLICABLE]

2.8. Are you or any person connected with the bidder presently employed by the state? YES NO

2.8.1. If so, furnish the following particulars:
 Name of person / director / trustee / shareholder/ member:
 Name of state institution at which you or the person connected to the bidder is employed:.....
 Position occupied in the state institution: Any other particulars:.....

2.8.2. If you are presently employed by the state, did you obtain the appropriate authority to undertake remunerative work outside employment in the public sector? YES NO

2.8.2.1. If yes, did you attach proof of such authority to the quote document?

(Note: Failure to submit proof of such authority, where applicable, may result in the disqualification of the quote.)

2.8.2.2. If no, furnish reasons for non-submission of such proof:

2.9. Did you or your spouse, or any of the company's directors / trustees / shareholders / members or their spouses conduct business with the state in the previous twelve months? YES NO

2.9.1. If so, furnish particulars:.....

2.10. Do you, or any person connected with the bidder, have any relationship (family, friend, other) with a person employed by the state and who may be involved with the evaluation and or adjudication of this quote? YES NO

2.10.1. If so, furnish particulars:.....

2.11. Are you, or any person connected with the bidder, aware of any relationship (family, friend, other) between any other bidder and any person employed by the state who may be involved with the evaluation and or adjudication of this quote? YES NO

2.11.1. If so, furnish particulars:.....

2.12. Do you or any of the directors / trustees / shareholders / members of the company have any interest in any other related companies whether or not they are bidding for this contract? YES NO

2.12.1. If so, furnish particulars:.....

3. Full details of directors / trustees / members / shareholders.

NB: The Department Of Health will validate **details of directors / trustees / members / shareholders** on CSD. It is the suppliers' responsibility to ensure that their details are up-to-date and verified on CSD. If the Department cannot validate the **information** on CSD, the quote will not be considered and passed over as non-compliant according to National Treasury Instruction Note 4 (a) 2016/17.

4 DECLARATION

I, THE UNDERSIGNED (NAME).....CERTIFY THAT THE INFORMATION FURNISHED IN PARAGRAPHS 2.

I ACCEPT THAT THE STATE MAY REJECT THE QUOTE OR ACT AGAINST ME SHOULD THIS DECLARATION PROVE TO BE FALSE.

..... Name of bidder Signature Position Date
-------------------------	--------------------	-------------------	---------------

¹"State" means -

- | | |
|---|---|
| a) any national or provincial department, national or provincial public entity or constitutional institution within the meaning of the Public Finance Management Act, 1999 (Act No. 1 of 1999); | c) provincial legislature; |
| b) any municipality or municipal entity; | d) national Assembly or the national Council of provinces; or |
| | e) Parliament. |

²"Shareholder" means a person who owns shares in the company and is actively involved in the management of the enterprise or business and exercises control over the enterprise.

SPECIAL CONTRACT CONDITIONS OF QUOTATIONS

1. AMENDMENT OF CONTRACT

- 1.1. Any amendment to or renunciation of the provisions of the contract shall at all times be done in writing and shall be signed by both parties.

2. CHANGE OF ADDRESS

- 2.1. Bidders must advise the Department of Health (institution where the offer was submitted) should their address (*domicilium citandi et executandi*) details change from the time of bidding to the expiry of the contract.

3. GENERAL CONDITIONS ATTACHED TO THIS QUOTATION

- 3.1. The institution is under no obligation to accept the lowest or any quote.
- 3.2. The price quoted must include VAT (if VAT vendor). However, it must be noted that the department reserves the right to evaluate all quotations excluding VAT as some bidders may not be VAT vendors.
- 3.3. The bidder must ensure the correctness & validity of quote:
- (i) *that the price(s), rate(s) & preference quoted cover all for the work/item (s) & accept that any mistakes regarding the price (s) & calculations will be at the bidder's risk*
- 3.4. The bidder must accept full responsibility for the proper execution & fulfilment of all obligations conditions devolving on under this agreement, as the Principal (s) liable for the due fulfilment of this contract.
- 3.5. This quotation will be evaluated based on the 80/20 points system, specification & correctness of information. All required documentation must be completed in full and submitted.
- 3.6. Offers must comply strictly with the specification.
- 3.7. Only offers that meet or are greater than the specification will be considered.
- 3.8. Late quotes will not be considered.
- 3.9. Expired product/s will not be accepted. All products supplied must be valid for a minimum period of six months.
- 3.10. A bidder not registered on the Central Suppliers Database or verification has failed will not be considered.
- 3.11. All delivery costs must be included in the quote price, for delivery at the prescribed destination.
- 3.12. Only firm prices will be accepted. Such prices must remain firm for the contract period. Non-firm prices (including rates of exchange variations) will not be considered.
- 3.13. In cases where different delivery points influence the pricing, a separate pricing schedule must be submitted for each delivery point.
- 3.14. In the event of a bidder having multiple quotes, only the cheapest according to specification will be considered. Furthermore a verification will be done to identify if bidders have multiple companies and are quoting (cover-quoting) for this bid. In such instances only the cheapest bid according to specification will be considered.

4. SPECIAL INSTRUCTIONS AND NOTICES TO BIDDERS REGARDING THE COMPLETION OF THIS QUOTATION.

- 4.1. Unless inconsistent with or expressly indicated otherwise by the context, the singular shall include the plural and vice versa and with words importing the masculine gender shall include the feminine and the neuter.
- 4.2. Under no circumstances whatsoever may the quotation/bid forms be retyped or redrafted. Photocopies of the original bid documentation may be used, but an original signature must appear on such photocopies.
- 4.3. The bidder is advised to check the number of pages and to satisfy himself that none are missing or duplicated.
- 4.4. Quotation submitted must be complete in all respects.
- 4.5. Any alteration made by the bidder must be initialled.
- 4.6. Use of correcting fluid is prohibited
- 4.7. Quotation will be opened in public as soon as practicable after the closing time of quotation.
- 4.8. Where practical, prices are made public at the time of opening quotations.
- 4.9. If it is desired to make more than one offer against any individual item, such offers should be given on a photocopy of the page in question. Clear indication thereof must be stated on the schedules attached.

5. SPECIAL INSTRUCTIONS REGARDING HAND DELIVERED QUOTATIONS

- 5.1. Quotation shall be lodged at the address indicated not later than the closing time specified for their receipt, and in accordance with the directives in the quotation documents.
- 5.2. Each quotation shall be addressed in accordance with the directives in the quotation documents and shall be lodged in a separate sealed envelope, with the name and address of the bidder, the quotation number and closing date indicated on the envelope. The envelope shall not contain documents relating to any quotation other than that shown on the envelope. If this provision is not complied with, such quotations/bids may be rejected as being invalid.
- 5.3. All quotations received in sealed envelopes with the relevant quotation numbers on the envelopes are kept unopened in safe custody until the closing time of the quotation/bids. Where, however, a quotation is received open, it shall be sealed. If it is received without a quotation/bid number on the envelope, it shall be opened, the quotation number ascertained, the envelope sealed and the quotation number written on the envelope.
- 5.4. A specific box is provided for the receipt of quotations, and no quotation found in any other box or elsewhere subsequent to the closing date and time of quotation will be considered.

- 5.5. No quotation/bid sent through the post will be considered if it is received after the closing date and time stipulated in the quotation documentation, and proof of posting will not be accepted as proof of delivery.
- 5.6. Quotation documents must not be included in packages containing samples. Such quotations may be rejected as being invalid.

6. SAMPLES

- 6.1. In the case of the quote document stipulating that samples are required, the supplier will be informed in due course when samples should be provided to the institution. (This decreases the time of safety and storage risk that may be incurred by the respective institution). The bidders sample will be retained if such bidder wins the contract.
 - (i) If a company/s who has not won the quote requires their samples, they must advise the institution in writing of such.
 - (ii) If samples are not collected within three months of close of quote the institution reserves the right to dispose of them at their discretion.
- 6.2. **Samples must be made available when requested in writing or if stipulated on the document.**
 - (i) If a Bidder fails to provide a sample of their product on offer for scrutiny against the set specification when requested, their offer will be rejected. All testing will be for the account of the bidder.

7. COMPULSORY SITE INSPECTION / BRIEFING SESSION

7.1. Bidders who fail to attend the compulsory meeting will be disqualified from the evaluation process.

- (i) The institution has determined that a compulsory site meeting take place
- (ii) Date ____/____/____ Time ____:____ Place _____

Institution Stamp:	Institution Site Inspection / briefing session Official Full Name: Signature: Date:
--------------------	--

8. STATEMENT OF SUPPLIES AND SERVICES

8.1. The contractor shall, when requested to do so, furnish particulars of supplies delivered or services executed. If he/she fails to do so, the Department may, without prejudice to any other rights which it may have, institute inquiries at the expense of the contractor to obtain the required particulars.

9. SUBMISSION AND COMPLETION OF SBD 6.1

9.1. Should a bidder wish to qualify for preference points they must complete a SBD 6.1 document. Failure by a bidder to provide all relevant information required, will result in such a bidder not being considered for preference point's allocation. The preferences applicable on the closing date will be utilized. Any changes after the closing date will not be considered for that particular quote.

10. TAX COMPLIANCE REQUIREMENTS

- 10.1. In the event that the tax compliance status has failed on CSD, **it is the suppliers' responsibility to provide a SARS pin in order for the institution to validate the tax compliance status of the supplier.**
- 10.2. In the event that the institution cannot validate the suppliers' tax clearance on SARS as well as the Central Suppliers Database, **the quote will not be considered and passed over as non-compliant according to National Treasury Instruction Note 4 (a) 2016/17.**

11. TAX INVOICE

11.1. A tax invoice shall be in the currency of the Republic of South Africa and shall contain the following particulars:

- (i) the name, address and registration number of the supplier;
- (ii) the name and address of the recipient;
- (iii) an individual serialized number and the date upon which the tax invoice is issued;
- (iv) a description and quantity or volume of the goods or services supplied;
- (v) the official department order number issued to the supplier;
- (vi) the value of the supply, the amount of tax charged;
- (vii) the words tax invoice in a prominent place.

12. PATENT RIGHTS

The supplier shall indemnify the **KZN Department of Health** (hereafter known as the purchaser) against all third-party claims of infringement of patent, trademark, or industrial design rights arising from use of the goods or any part thereof by the purchaser.

13. PENALTIES

- 13.1. If at any time during the contract period, the service provider is unable to perform in a timely manner, the service provider must notify the institution in writing/email of the cause of and the duration of the delay. Upon receipt of the notification, the institution should evaluate the circumstances and, if deemed necessary, the institution may extend the service provider's time for performance.
- 13.2. In the event of delayed performance that extends beyond the delivery period, the institution is entitled to purchase commodities of a similar quantity and quality as a substitution for the outstanding commodities, without terminating the contract, as well as return commodities delivered at a later stage at the service provider's expense.
- 13.3. Alternatively, the institution may elect to terminate the contract and procure the necessary commodities in order to complete the contract. In the event that the contract is terminated the institution may claim damages from the service provider in the form of a penalty. The service provider's performance should be captured on the service provider database in order to determine whether or not the service provider should be awarded any contracts in the future.
- 13.4. If the supplier fails to deliver any or all of the goods or to perform the services within the period(s) specified in the contract, the purchaser shall, without prejudice to its other remedies under the contract, deduct from the contract price, as a penalty, a sum calculated on the delivered price of the delayed goods or unperformed services using the current prime interest rate calculated for each day of the delay until actual delivery or performance.

14. TERMINATION FOR DEFAULT

- 14.1. The purchaser, without prejudice to any other remedy for breach of contract, by written notice of default sent to the supplier, may terminate this contract in whole or in part:
 - (i) if the supplier fails to deliver any or all of the goods within the period(s) specified in the contract,
 - (ii) if the supplier fails to perform any other obligation(s) under the contract; or
 - (iii) if the supplier, in the judgment of the purchaser, has engaged in corrupt or fraudulent practices in competing for or in executing the contract.
- 14.2. In the event the purchaser terminates the contract in whole or in part, the purchaser may procure, upon such terms and in such manner as it deems appropriate, goods, works or services similar to those undelivered, and the supplier shall be liable to the purchaser for any excess costs for such similar goods, works or services.
- 14.3. Where the purchaser terminates the contract in whole or in part, the purchaser may decide to impose a restriction penalty on the supplier by prohibiting such supplier from doing business with the public sector for a period not exceeding 10 years.

15. FAILURE TO COMPLY WITH ABOVE WILL RESULT IN YOUR QUOTE BEING PASSED OVER.

PREFERENCE POINTS CLAIM FORM IN TERMS OF THE PREFERENTIAL PROCUREMENT REGULATIONS 2017

This preference form must form part of all quotes invited. It contains general information and serves as a claim form for preference points for Broad-Based Black Economic Empowerment (B-BBEE) Status Level of Contribution

NB: BEFORE COMPLETING THIS FORM, BIDDERS MUST STUDY THE GENERAL CONDITIONS, DEFINITIONS AND DIRECTIVES APPLICABLE IN RESPECT OF B-BBEE, AS PRESCRIBED IN THE PREFERENTIAL PROCUREMENT REGULATIONS, 2017.

1. GENERAL CONDITIONS

- 1.1 The following preference point systems are applicable to all quotes:
- the 80/20 system for requirements with a Rand value of up to R50 000 000 (all applicable taxes included); and
- 1.2 The value of this quote is estimated to not exceed R50 000 000 (all applicable taxes included) and therefore the 80/20 preference point system shall be applicable.
- 1.3 Points for this quote shall be awarded for:
- (a) Price; and
 - (b) B-BBEE Status Level of Contributor.
- 1.4 The maximum points for this quote is allocated as follows:

	POINTS
PRICE	80
B-BBEE STATUS LEVEL OF CONTRIBUTOR	20
Total points for Price and B-BBEE must not exceed	100

- 1.5 Failure on the part of a bidder to submit proof of B-BBEE Status level of contributor together with the quote, will be interpreted to mean that preference points for B-BBEE status level of contribution are not claimed.
- 1.6 The purchaser reserves the right to require of a bidder, either before a quote is adjudicated or at any time subsequently, to substantiate any claim in regard to preferences, in any manner required by the purchaser.

2. DEFINITIONS

- (a) **"B-BBEE"** means broad-based black economic empowerment as defined in section 1 of the Broad-Based Black Economic Empowerment Act;
- (b) **"B-BBEE status level of contributor"** means the B-BBEE status of an entity in terms of a code of good practice on black economic empowerment, issued in terms of section 9(1) of the Broad-Based Black Economic Empowerment Act;
- (c) **"bid"** means a written offer in a prescribed or stipulated form in response to an invitation by an organ of state for the provision of goods or services, through price quotations, advertised competitive bidding processes or proposals;
- (d) **"Broad-Based Black Economic Empowerment Act"** means the Broad-Based Black Economic Empowerment Act, 2003 (Act No. 53 of 2003);
- (e) **"EME"** means an Exempted Micro Enterprise in terms of a code of good practice on black economic empowerment issued in terms of section 9 (1) of the Broad-Based Black Economic Empowerment Act;
- (f) **"functionality"** means the ability of a tenderer to provide goods or services in accordance with specifications as set out in the tender documents.
- (g) **"prices"** includes all applicable taxes less all unconditional discounts;
- (h) **"proof of B-BBEE status level of contributor"** means:
 - 1) B-BBEE Status level certificate issued by an authorized body or person;
 - 2) A sworn affidavit as prescribed by the B-BBEE Codes of Good Practice;
 - 3) Any other requirement prescribed in terms of the B-BBEE Act;
- (i) **"QSE"** means a qualifying small business enterprise in terms of a code of good practice on black economic empowerment issued in terms of section 9 (1) of the Broad-Based Black Economic Empowerment Act;
- (j) **"rand value"** means the total estimated value of a contract in Rand, calculated at the time of bid invitation, and includes all applicable taxes;

3. POINTS AWARDED FOR PRICE

3.1 THE 80/20 PREFERENCE POINT SYSTEMS

A maximum of 80 points is allocated for price on the following basis:

$$P_s = 80 \left(1 - \frac{P_t - P_{\min}}{P_{\min}} \right) \text{ Where}$$

- P_s = Points scored for price of bid under consideration
- P_t = Price of bid under consideration
- P_{min} = Price of lowest acceptable bid

4. POINTS AWARDED FOR B-BBEE STATUS LEVEL OF CONTRIBUTOR

4.1 In terms of Regulation 6 (2) and 7 (2) of the Preferential Procurement Regulations, preference points must be awarded to a bidder for attaining the B-BBEE status level of contribution in accordance with the table below:

B-BBEE Status Level of Contributor	Number of points (80/20 system)
1	20
2	18
3	14
4	12
5	8
6	6
7	4
8	2
Non-compliant contributor	0

5. BID DECLARATION

5.1 Bidders who claim points in respect of B-BBEE Status Level of Contribution must complete the following:

6. B-BBEE STATUS LEVEL OF CONTRIBUTOR CLAIMED IN TERMS OF PARAGRAPHS 1.4 AND 4.1

6.1 B-BBEE Status Level of Contributor: =(maximum of 20 points)

(Points claimed in respect of paragraph 7.1 must be in accordance with the table reflected in paragraph 4.1 and must be substantiated by relevant proof of B-BBEE status level of contributor.

7. SUB-CONTRACTING

(Tick applicable box)

7.1 Will any portion of the contract be sub-contracted?

YES	NO	
-----	----	--

7.1.1 If yes, indicate:

- i) What percentage of the contract will be subcontracted.....%
- ii) The name of the sub-contractor.....
- iii) The B-BBEE status level of the sub-contractor.....

8. Whether the sub-contractor is an EME or QSE

(Tick applicable box)

iv) Specify, by ticking the appropriate box, if subcontracting with an enterprise in terms of Preferential Procurement Regulations, 2017:

YES	NO	
-----	----	--

Designated Group: An EME or QSE which is at least 51% owned by:	EME	QSE
Black people	√	√
Black people who are youth		
Black people who are women		
Black people with disabilities		
Black people living in rural or underdeveloped areas or townships		
Cooperative owned by black people		
Black people who are military veterans		
OR		
Any EME		
Any QSE		

9. **DECLARATION WITH REGARD TO COMPANY/FIRM**

9.1 Name of company/firm:.....

9.2 VAT registration number:.....

9.3 Company registration number:.....

9.4 TYPE OF COMPANY/ FIRM [TICK APPLICABLE BOX]

- Partnership/Joint Venture / Consortium
- One person business/sole propriety
- Close corporation
- Company
- (Pty) Limited

9.5 DESCRIBE PRINCIPAL BUSINESS ACTIVITIES

.....
.....

9.6 COMPANY CLASSIFICATION [TICK APPLICABLE BOX]

- Manufacturer
- Supplier
- Professional service provider
- Other service providers, e.g. transporter, etc.

9.7 Total number of years the company/firm has been in business:.....

9.8 I/we, the undersigned, who is / are duly authorised to do so on behalf of the company/firm, certify that the points claimed, based on the B-BBE status level of contributor indicated in paragraphs 1.4 and 6.1 of the foregoing certificate, qualifies the company/ firm for the preference(s) shown and I / we acknowledge that:

- i) The information furnished is true and correct;
- ii) The preference points claimed are in accordance with the General Conditions as indicated in paragraph 1 of this form;
- iii) In the event of a contract being awarded as a result of points claimed as shown in paragraphs 1.4 and 6.1, the contractor may be required to furnish documentary proof to the satisfaction of the purchaser that the claims are correct;
- iv) If the B-BBEE status level of contributor has been claimed or obtained on a fraudulent basis or any of the conditions of contract have not been fulfilled, the purchaser may, in addition to any other remedy it may have –
 - (a) disqualify the person from the bidding process;
 - (b) recover costs, losses or damages it has incurred or suffered as a result of that person's conduct;
 - (c) cancel the contract and claim any damages which it has suffered as a result of having to make less favourable arrangements due to such cancellation;
 - (d) recommend that the bidder or contractor, its shareholders and directors, or only the shareholders and directors who acted on a fraudulent basis, be restricted by the National Treasury from obtaining business from any organ of state for a period not exceeding 10 years, after the *audi alteram partem* (hear the other side) rule has been applied; and
 - (e) forward the matter for criminal prosecution.

<p>WITNESSES</p> <p>1.</p> <p>2.</p>

<p>.....</p> <p>SIGNATURE(S) OF BIDDERS(S)</p> <p>DATE:</p> <p>ADDRESS.....</p> <p>.....</p> <p>.....</p>
--

PRIVATE SPECIFICATION

Prepared for



MEN'S COMBAT CUSTOMS BUNNY JACKET WITH EPAULETTES



CBCU 013

Version 02.0/September 2016

Copyright reserved

1. Scope

This specification covers the material, cut and make of bunny jackets for male personnel of SARS Customs.

2. Definitions and Abbreviations

For the purpose of this specification the definitions given in SANS 10371 "Terms and definitions for clothing" and the following shall apply:

acceptable: acceptable to SARS Customs

nominal: subject to the tolerances normal to good manufacturing practice

SANS: South African National Standard

3. Style

The style is as follows:

- ◆ single breasted
- ◆ storm flap
 - conceals the slide fastener front closure
 - fitted with press-stud fasteners
- ◆ shoulder straps
- ◆ left front and back to be fitted with embroidery
- ◆ right front to be fitted with an embossed badge
- ◆ front and back yoke
- ◆ front and back neck facings
- ◆ one-piece collar
- ◆ two side pockets
- ◆ one front facing jetted pocket
- ◆ one-piece set-in sleeves
 - sleeves to be long
 - separate cuffs with press-stud fastening
- ◆ have a fully elasticized waistband
- ◆ fully lined (body and sleeves)
 - lining to be fitted with two patch pockets (one sewn on top of the other)
- ◆ have a detachable warm lining (body) with:
 - through opening
 - fitted with two patch pockets sewn on top of each other
 - slide fastener that attaches warm lining to garment

Doc No	Date	Responsibility	Version	Pages
CBCU 013	September 2016	SARS	02.0	Page 2 of 32

4. Illustrations

Illustrations are not to scale and are for guidance only.

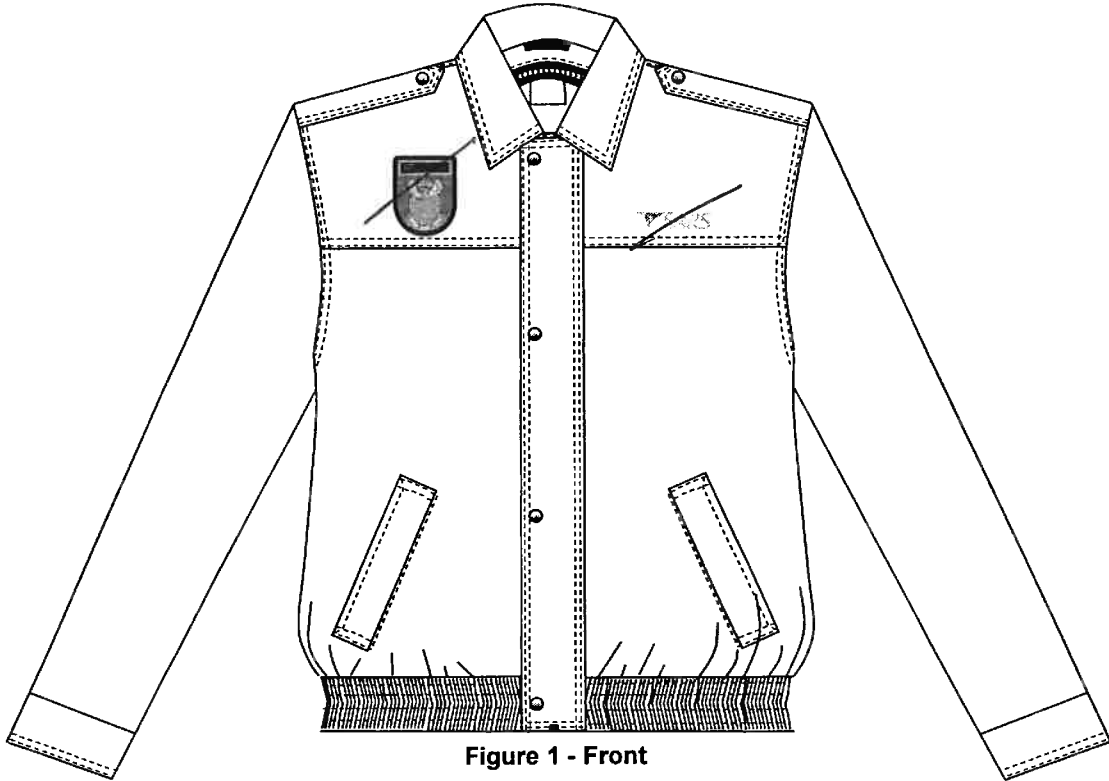

Figure 1 - Front

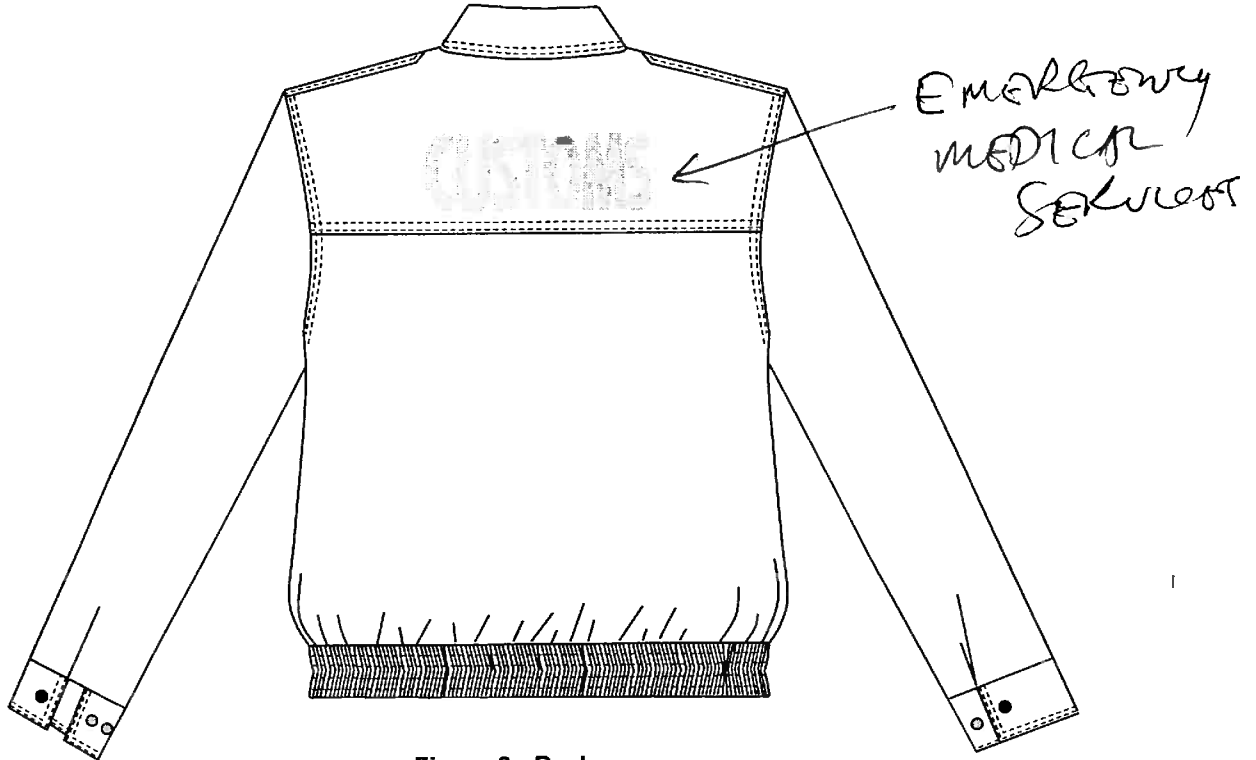

Figure 2 - Back

Doc No	Date	Responsibility	Version	Pages
CBCU 013	September 2016	SARS	02.0	Page 3 of 32

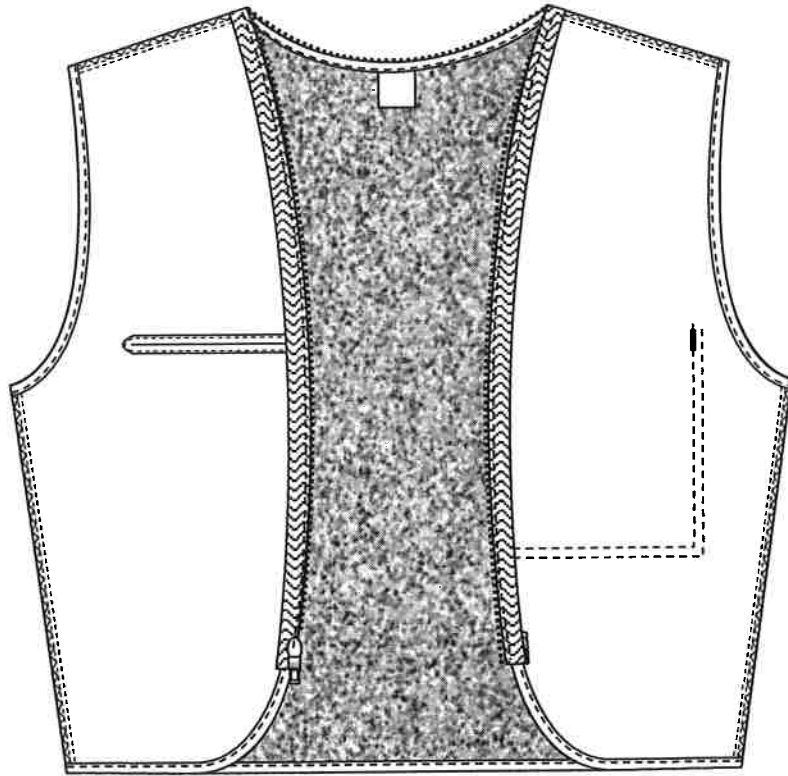

Figure 3(a) – Detachable warm inner (as when zipped into the jacket)

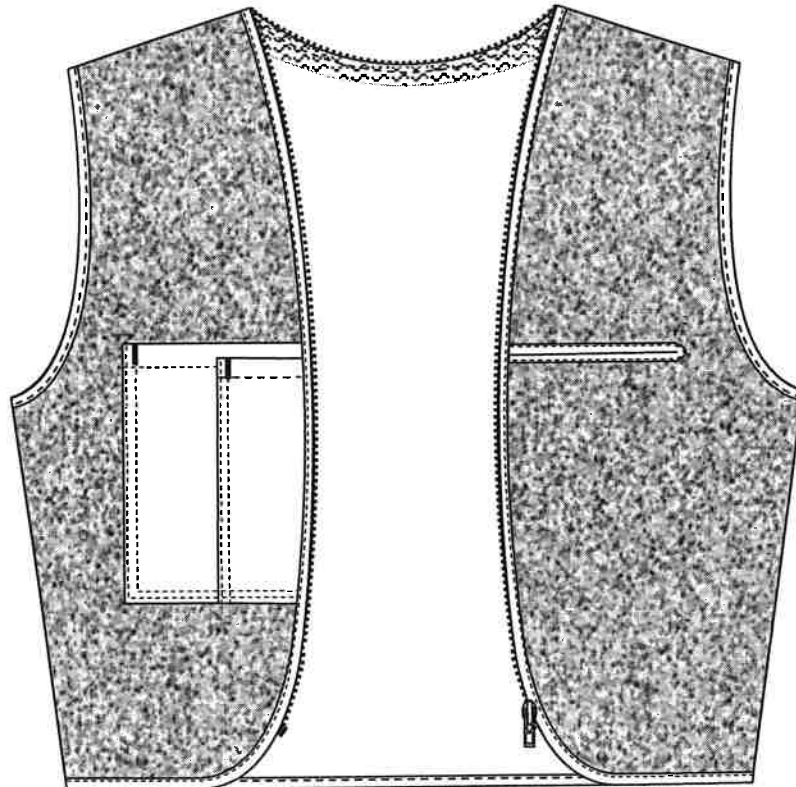

Figure 3(b) – Detachable warm inner

Doc No	Date	Responsibility	Version	Pages
CBCU 013	September 2016	SARS	02.0	Page 4 of 32

5. Client Furnished Materials

SARS Customs shall place an order on a relevant badge supplier who will manufacture the embossed badges. The onus shall be on the jacket manufacturer to request the correct amount of embossed badges from the identified badge manufacturer. The transport, delivery and attachment of the embossed badges shall be for the jacket manufacturer's account.

- ◆ quantity supplied shall be in accordance with the quantity of jackets ordered
- ◆ badges for pre-production samples to be supplied additionally

SARS shall provide a spreadsheet containing the persal number, name and relevant jacket size that pertains to each individual for each order (see paragraph 12.2).

6. Component Materials

The following materials shall be supplied and used by the manufacturer. A trim chart containing the components shall accompany each pre-production sample (see Annex A).

6.1 Outer material

- ◆ to comply with the requirements for type RPR 66 of SANS 1387-11 "Woven cotton and similar apparel fabrics – Part 11: Polyester-and-cellulosic raincoat fabrics"
- ◆ colour to be an acceptable match, in terms of SANS 10076-1, "The assessment of defects in textile piece-goods and made-up articles Part 1: Defects in woven piece-goods (cellulosic and cellulosic blends)", to colour No. 206c-2013 "SARS Charcoal" of CKS 129 "Colours for textiles"
- ◆ see Annex B for colour registration procedure (as relevant)

6.2 Interlining

- ◆ an acceptable fusible interlining
- ◆ to comply with the requirements of CKS 627 "Fusible interlinings"
- ◆ mass per area to be suitable for use in the collar, front facing, collar, pockets, cuff and waistband
- ◆ capable of withstanding the same washing and drying procedures as specified for the outer garment
- ◆ colour to be an acceptable match to the colour of the outer material

The selection of interlining of appropriate mass per unit area to be determined by consultation with the supplier of the interlining. The manufacturer will be held responsible for the performance of the interlining.

The purchaser reserves the right to change the type of interlining used during production, should the appearance of the finished garments be unsatisfactory.

6.3 Lining

- ◆ polyester lining that complies with the requirements for type L61P SANS 1387-7 "Woven cotton and similar apparel fabrics – Part 7: Jacket linings"

Doc No	Date	Responsibility	Version	Pages
CBCU 013	September 2016	SARS	02.0	Page 5 of 32

- ◆ colour to be an acceptable match to the colour of the outer material

6.4 Slide fastener

- ◆ to comply with the requirements of SANS 1822 "Slide fasteners"
- ◆ to comply with the requirements for performance class B slide fasteners
- ◆ synthetic chain
- ◆ one-way open end
- ◆ colour to be an acceptable match to the colour of the outer material

6.5 Laminated lining fabric

- ◆ a laminated polyester fabric that complies with the requirements as given in table 1
- ◆ colour to be an acceptable match to the colour of the outer material

Table 1 – Laminated warm lining fabric requirements

1	2	3
Property	Requirement	SANS number (unless otherwise indicated)
Structure	Knitted polar fleece with brushed pile laminated to plain woven lining material	Visual examination
Overall fibre composition, %	All polyester microfibre	AATCC method 20
Mass per unit area, g/m ² , min.	300	79
Resistance to pilling, rating, min.	3-4	6116 ^a
Dimensional changes on washing, %, max.		960
Length	3	Procedure C
Width	3	Dry flat
Colour fastness to:		
Water, rating, min.		105-C10 Test (A1)
Change in colour	4	
Staining	4	
Perspiration, rating, min.		105-E04
Change in colour	4	
Staining	4	
Light, rating, min.	5	105-B02

^a Brushed polar fleece side facing upwards when placed under test apparatus.
Test after a pre-treatment in accordance with the prescribed test method for dimensional changes on washing.

6.6 Elastic webbing

- ◆ to be of minimum width 50 mm
- ◆ to comply with the requirements for type 1 of SANS 142 "Narrow elastic fabrics and strip"

Doc No	Date	Responsibility	Version	Pages
CBCU 013	September 2016	SARS	02.0	Page 6 of 32

6.7 Press-stud fasteners

NOTE: All sections where press-studs are applied shall be reinforced on the inside to prevent the press-stud from tearing out of the garment.

- ◆ acceptable brass base press-stud fasteners
- ◆ to have a gun metal finish
- ◆ to consist of a cap, socket, stud and post
- ◆ nominal outside diameter of female section to be 15 mm
- ◆ male and female type
- ◆ smooth finish

6.8 Embroidery thread

- ◆ to be 100% Viscose Rayon Machine embroidery thread
- ◆ colour ref. 0608 (ACA Threads) or colour ref. 1008 (Marathon Thread)

6.9 Threads

- ◆ to comply with relevant requirements of SANS 1362 "Sewing threads"
- ◆ colour to be an acceptable match to the colour of the outer material

Sewing and top-stitching thread:

- ◆ polyester-and-cotton core-spun **OR** staple polyester
- ◆ ticket No 80 in both cases

Overlocking thread:

- ◆ crimp-textured polyester **OR** polyamide
- ◆ ticket No 140

Doc No	Date	Responsibility	Version	Pages
CBCU 013	September 2016	SARS	02.0	Page 7 of 32

7. Workmanship

The jackets shall be:

- ◆ cut and made with first-class workmanship throughout
- ◆ of uniform and acceptable make, colour and finish

Shall be free from:

- ◆ defects, that affect their appearance or may affect their serviceability (or both)
- ◆ marks
- ◆ spots
- ◆ stains, incurred in the making-up
- ◆ sobar labels

Seams and stitches shall be:

- ◆ smooth and uniform
- ◆ free from twists, pleats and puckers
- ◆ sufficiently extensible to avoid seam cracking and undue shrinkage in use

Ends of sewing shall be:

- ◆ trimmed and loose threads removed
- ◆ back-tacked if unsecured

Doc No	Date	Responsibility	Version	Pages
CBCU 013	September 2016	SARS	02.0	Page 8 of 32

8. Sizes and dimensions

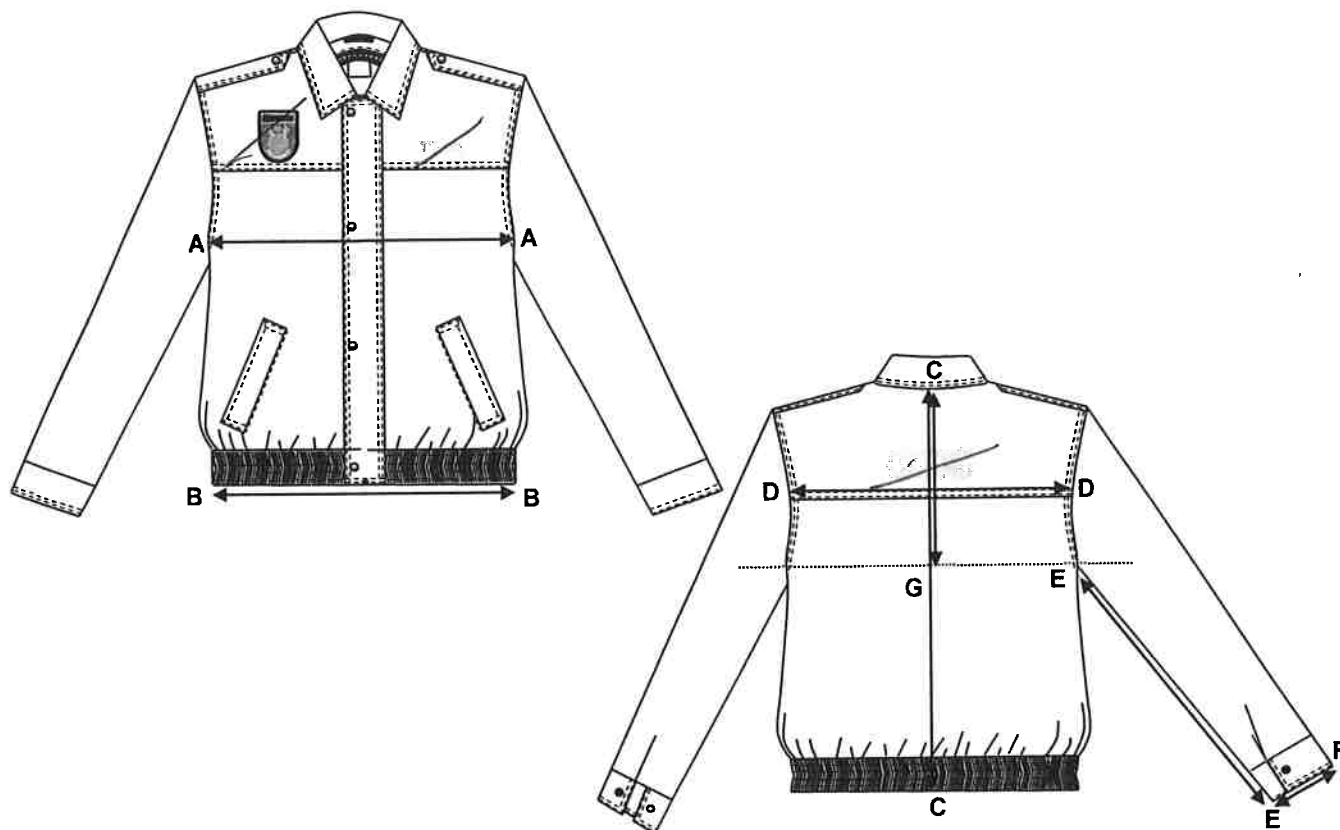

Jacket measurements:

Measuring point		Description
A – A	Chest circumference	Measure at the base of the scye, with garment spread completely flat, slide fastener fastened and multiply by two.
B – B	Waist relaxed	Measure at the bottom edge of the jacket, without stretching the elastic, and multiply by two.
B – B	Waistband extended	Measure at the bottom edge of the jacket, stretching the elastic to the maximum, and multiply by two.
C – C	Back length	Measure from the centre back neck seam to the bottom edge of the garment.
D – D	Back width	Measure along the back yoke seam.
E – E	Sleeve length	Measure along the underarm seam, from the base of the scye to the outer edge of the cuff.
E – F	Cuff circumference	Measure across the bottom edge of the cuff, with the cuff fastened to the first male press-stud, and multiply by two.
C – G	Depth of scye	Measure the length from the centre back neck seam to a point, level with the base of the scye.

Doc No	Date	Responsibility	Version	Pages
CBCU 013	September 2016	SARS	02.0	Page 9 of 32

Table 2 – Size range

1 Size designation ¹	2		3		4		5		6		7		8	
	Chest circumference	Back length	Back width	Sleeve length	Cuff circumference	Extended waist circumference ²	Depth of scye ³	Nominal finished garment measurements, cm						
X-Small 77/82	110	70	49	48	25	110	29							
Small 87/92	120	71	51	49	26	120	30							
Medium 97/102	130	72	53	50	27	130	31							
Large 107/112	140	73	55	51	28	140	32							
X-Large 117/122	150	74	57	52	29	150	33							
2X-Large 127/132	160	75	59	53	30	160	34							
3X-Large 137/142	170	76	61	54	31	170	35							

1 Based on the chest circumference of the intended wearer in centimetres.
 2 Relaxed waist circumference shall be as agreed upon between SARS and the manufacturer.
 3 Given as a guideline only.

Doc No	Date	Responsibility	Version	Pages
CBCU 013	September 2016	SARS	02.0	Page 10 of 32

9. Make

Illustrations are not to scale and are for guidance only, and unless inconsistent with the text, all measurements are nominal.

9.1 Foreparts

Foreparts shall:

- ◆ be single breasted
- ◆ fasten with a slide fastener
 - to extend from the gorge seam to the bottom edge of the waistband
 - stringers to be sandwiched between the front facing and front edge of forepart edge
 - edge-stitched 2 mm and 8 mm from the front edges respectively
 - covered with a storm flap
- ◆ be fully lined with lining

Each forepart shall:

- ◆ consist of two parts:
 - **front yoke**
 - **lower section** that shall consist of a single panel
- ◆ have a facing
- ◆ have a welted side pocket
- ◆ be fitted with a male section of a press-stud at the shoulder seam area that corresponds with the female press-stud in the shoulder strap

Each left forepart shall be as follows:

- ◆ be fitted with a storm flap and embroidery

Each right forepart shall:

- ◆ be fitted with an embossed badge
- ◆ be fitted with four press-studs
 - male sections
 - in corresponding positions to the female sections on the storm flap

Doc No	Date	Responsibility	Version	Pages
CBCU 013	September 2016	SARS	02.0	Page 11 of 32

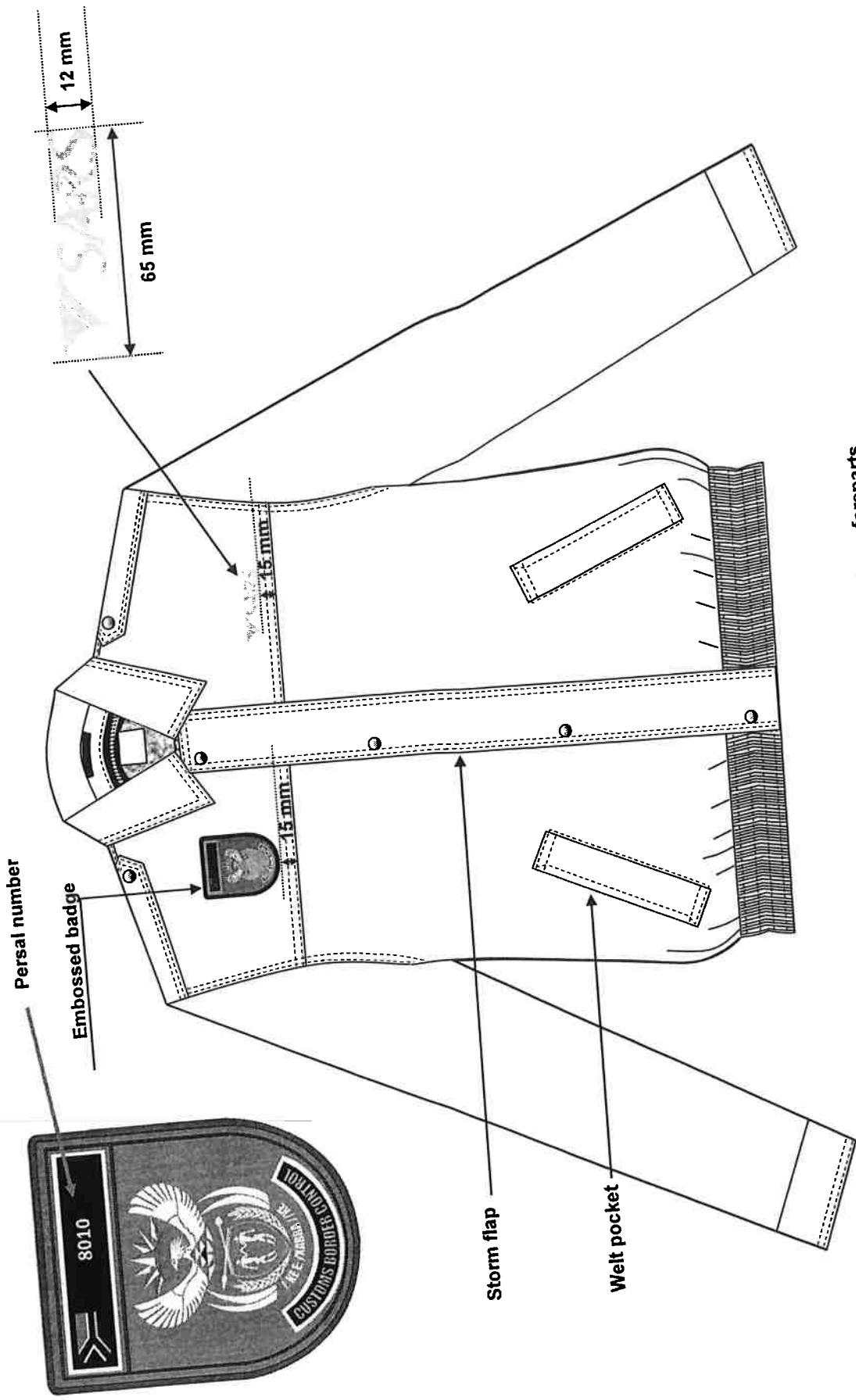

Figure 4 – Design components on foreparts

Doc No	Date	Responsibility	Version	Pages
CBCU 013	September 2016	SARS	02.0	Page 12 of 32

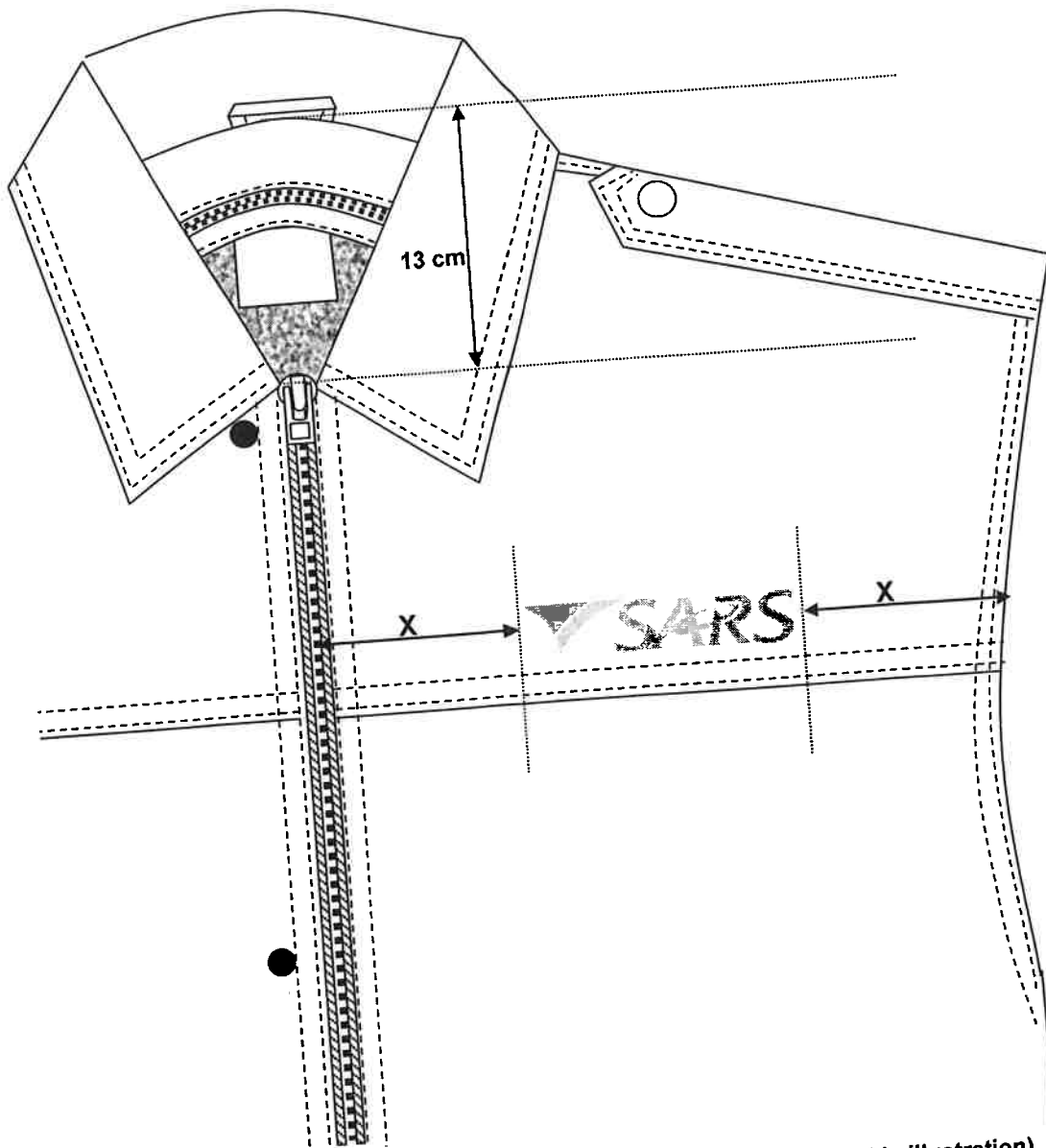

Figure 5 – Front Embroidery (storm flap omitted on this illustration).

9.2 Front yoke

Each front yoke

- ♦ on size Small, the centre front length of the yoke shall be 10 cm (measured from the gorge seam) and graded proportionally for smaller and larger sizes
- ♦ yoke and shoulder seams to be top-stitched 2 mm and 8 mm from the edge
- ♦ shall be such that the shoulder seam is 17,5 cm on size Small and graded proportionally on the smaller and larger sizes

NOTE 1: The front yoke seam is a fixed point and the yoke shall be graded in length only at the neck and shoulder seams.

NOTE 2: The neck drop shall be 13 cm when measured in a straight line from the centre back collar seam to the gorge seam.

Doc No	Date	Responsibility	Version	Pages
CBCU 013	September 2016	SARS	02.0	Page 13 of 32

The left front yoke shall:

- ◆ be fitted with embroidery
 - embroidered with embroidery thread and positioned as given in figures 4 and 5
 - the SARS logo shall be an exact copy of the registered logo and of dimensions as given in figure 4

The right front yoke shall:

- ◆ be fitted with an embossed badge (supplied by SARS Customs)
 - positioned as given in figure 4 and centrally positioned between the centre front and the sleeve insertion seam
 - sewn through the outer material only (NOT through lining as well)

NOTE 3: SARS Customs reserves the right to change the positioning of the embroidery and badge after the pre-production samples have been submitted.

9.3 Storm flap

The storm flap to:

- ◆ overlap left over right
- ◆ be lined with outer material
- ◆ interlined with interlining
- ◆ of finished width 60 mm
- ◆ extend from the gorge seam to the bottom edge of the jacket
- ◆ be sewn to the left forepart, 25 mm from the front edge, turned over and top-stitched 2 mm and 8 mm from the turned-over edge
- ◆ such that the free edges shall be top-stitched 2 mm and 8 mm
- ◆ be fitted with four press-studs
 - female sections
 - positioned 15 mm from the front free edges (centres)
 - topmost fastener shall be centred 20 mm from the top edge of the flap
 - bottom press-stud section shall be centred 20 mm from the bottom edge of the flap
 - remaining two fasteners to be spaced equidistantly between the top and bottom fasteners

9.4 Pockets

Each jacket shall have:

- ◆ two outside welted pockets
- ◆ one facing pocket (see 9.5)
- ◆ one lining in-breast pocket (see 9.6)
- ◆ one lining pen pocket (see 9.6)
- ◆ one detachable warm lining pocket (see 9.13)
- ◆ one detachable warm lining pen pocket (see 9.13)

Outside welted pockets:

- ◆ slanted
- ◆ swing type
- ◆ positioned with the top of the pocket mouth \pm 1/3 of the width of the forepart (measured from the side seam)
- ◆ bottom of pocket mouth shall not be less than 60 mm above the waistband seam
- ◆ bottom edge to be positioned at a 75 ° angle (see figure 6)
- ◆ welts to be:
 - of double folded outer material

Doc No	Date	Responsibility	Version	Pages
CBCU 013	September 2016	SARS	02.0	Page 14 of 32

- of finished width 40 mm
- of finished length 17 cm
- top-stitched 2 mm and 8 mm from the side edges
- top-stitched 8 mm from the free edges
- ◆ pocket bags:
 - rear part to be of outer material
 - top part to be of lining
 - shall not be caught in with the waistband
 - of finished width 18 cm (measured from the outer bottom edge of the welt)
 - of finished depth 55 mm (below the lower edge of the welt)

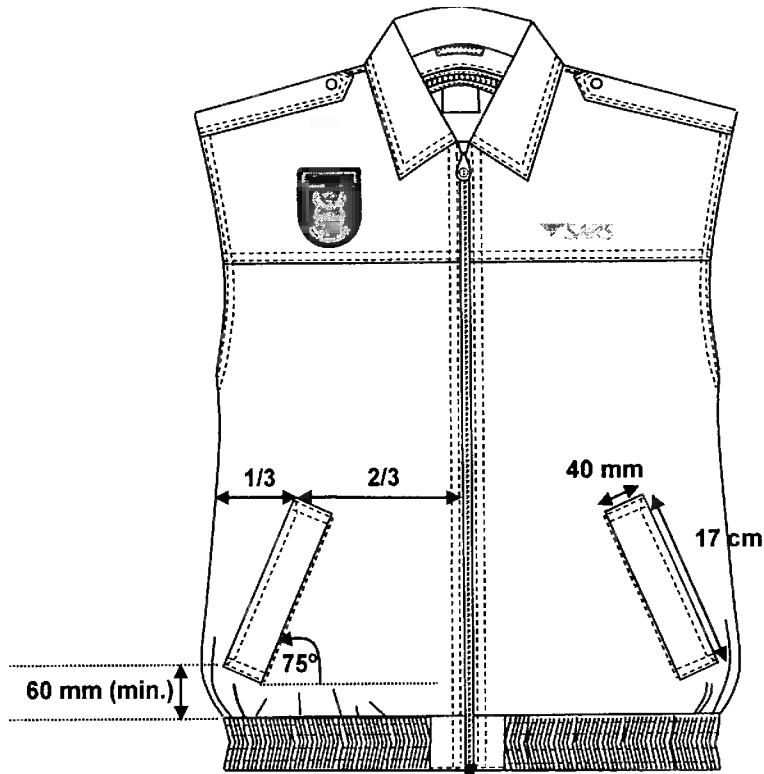

Figure 6 – Outside welt pockets (Storm flap omitted in illustration)

Doc No	Date	Responsibility	Version	Pages
CBCU 013	September 2016	SARS	02.0	Page 15 of 32

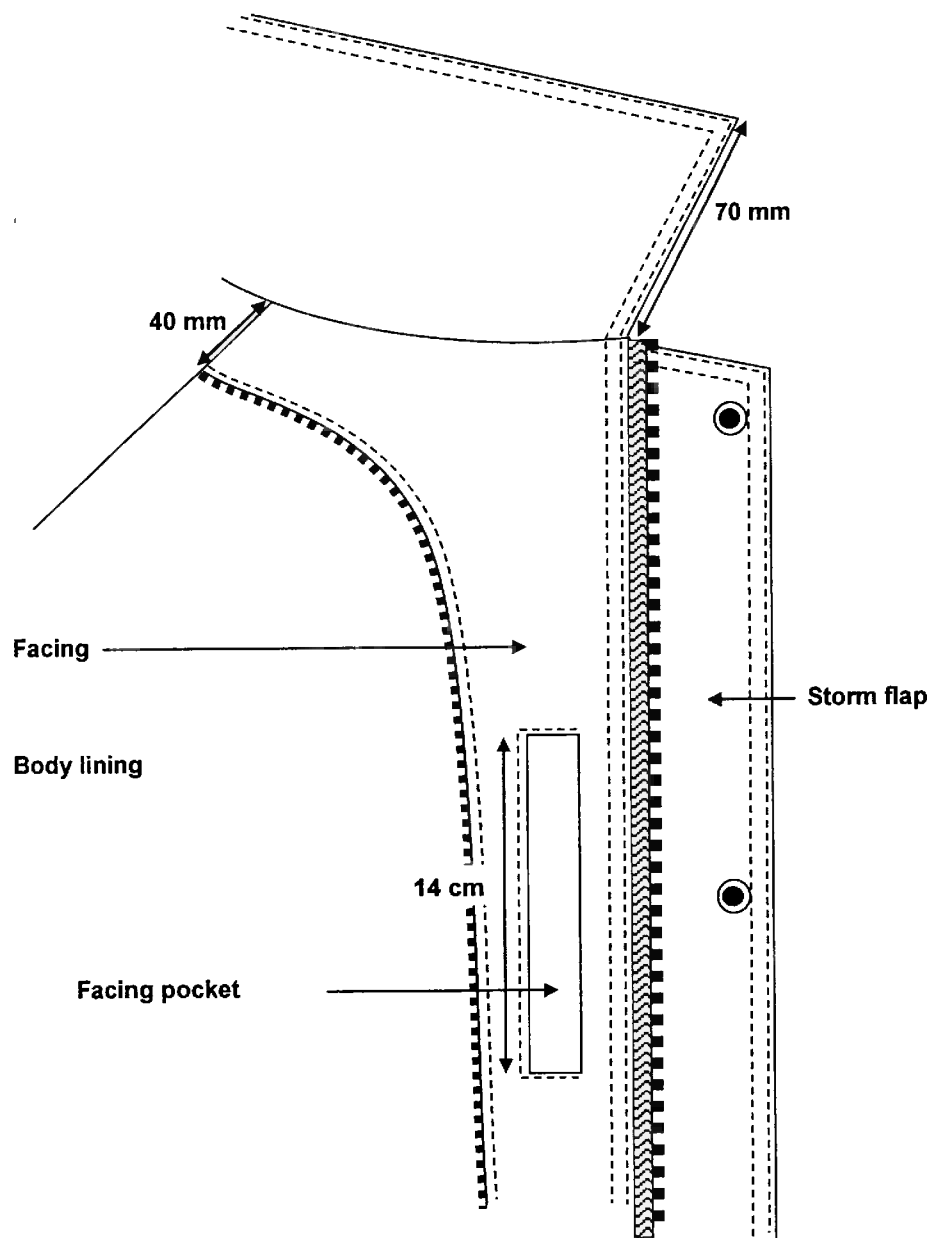

Figure 7 – Left inside facing

9.5 Facings

Each forepart and back neck shall have a facing

Front facings:

- ◆ of outer material
- ◆ lined with interlining
- ◆ of finished width 40 mm, measured at the shoulder seam, shaped to 50 mm at the waistband seam
- ◆ sewn to the body lining
- ◆ fitted with a pocket (left front facing only)
 - vertically positioned
 - single inlaid jetting of outer material
 - of finished length 14 cm
 - top of pocket to be positioned approximately 50 mm below the front yoke seam
 - centred in the width of the facing

Doc No	Date	Responsibility	Version	Pages
CBCU 013	September 2016	SARS	02.0	Page 16 of 32

- pocket bags to be of lining and of finished width 15 cm and finished depth 10 cm (measured at the base of the pocket mouth)

Back facings:

- ◆ of outer material
- ◆ lined with interlining
- ◆ of finished width 40 mm, measured at the centre back

9.6 Lining

- ◆ the body and sleeves to be fully lined with lining
- ◆ sewn to the front and back neck facings
- ◆ fitted with a stringer of a slide fastener which shall be sandwiched between the facing-to-lining seam
 - stringer to extend from approximately 90 mm above the bottom edge of the waistband of left forepart, round the neck to approximately 90 mm above the bottom edge of the waistband of the right forepart
 - this stringer shall correspond with the stringer on the detachable warm lining
 - the puller and slider shall be positioned at the bottom of the left forepart when the slide fastener is fastened
- ◆ right forepart lining shall incorporate an in-breast pocket and a pen pocket

In-breast pocket:

- ◆ of outer material
- ◆ to be a patch pocket
- ◆ to have square corners
- ◆ to be of finished width 16 cm
- ◆ to be of finished depth 21 cm
- ◆ positioned with the top edge of the pocket 30 mm above the base of the scye
- ◆ front edge to be sewn in with the front facing and stringer
- ◆ mouth end to be vertically bar-tacked
- ◆ pocket mouth hem to be of finished width 20 mm
- ◆ side and bottom edges to be turned in 10 mm and stitched down 2 mm and 8 mm from the edges

Pen pocket:

- ◆ to be sewn on top of the in-breast patch pocket
- ◆ to be a patch pocket
- ◆ of outer material
- ◆ to have square corners
- ◆ to be of finished width 70 mm
- ◆ to be of finished depth 19,5 cm
- ◆ bottom edge to be aligned with the bottom edge of the in-breast pocket
- ◆ front edge to be sewn in with the front facing and stringer
- ◆ mouth end to be vertically bar-tacked
 - pocket mouth hem to be of finished width 15 mm
 - side and bottom edges to be turned in 10 mm and stitched down 2 mm and 8 mm from the edges

NOTE: The stringer on the detachable warm lining shall house the puller and slider.

Doc No	Date	Responsibility	Version	Pages
CBCU 013	September 2016	SARS	02.0	Page 17 of 32

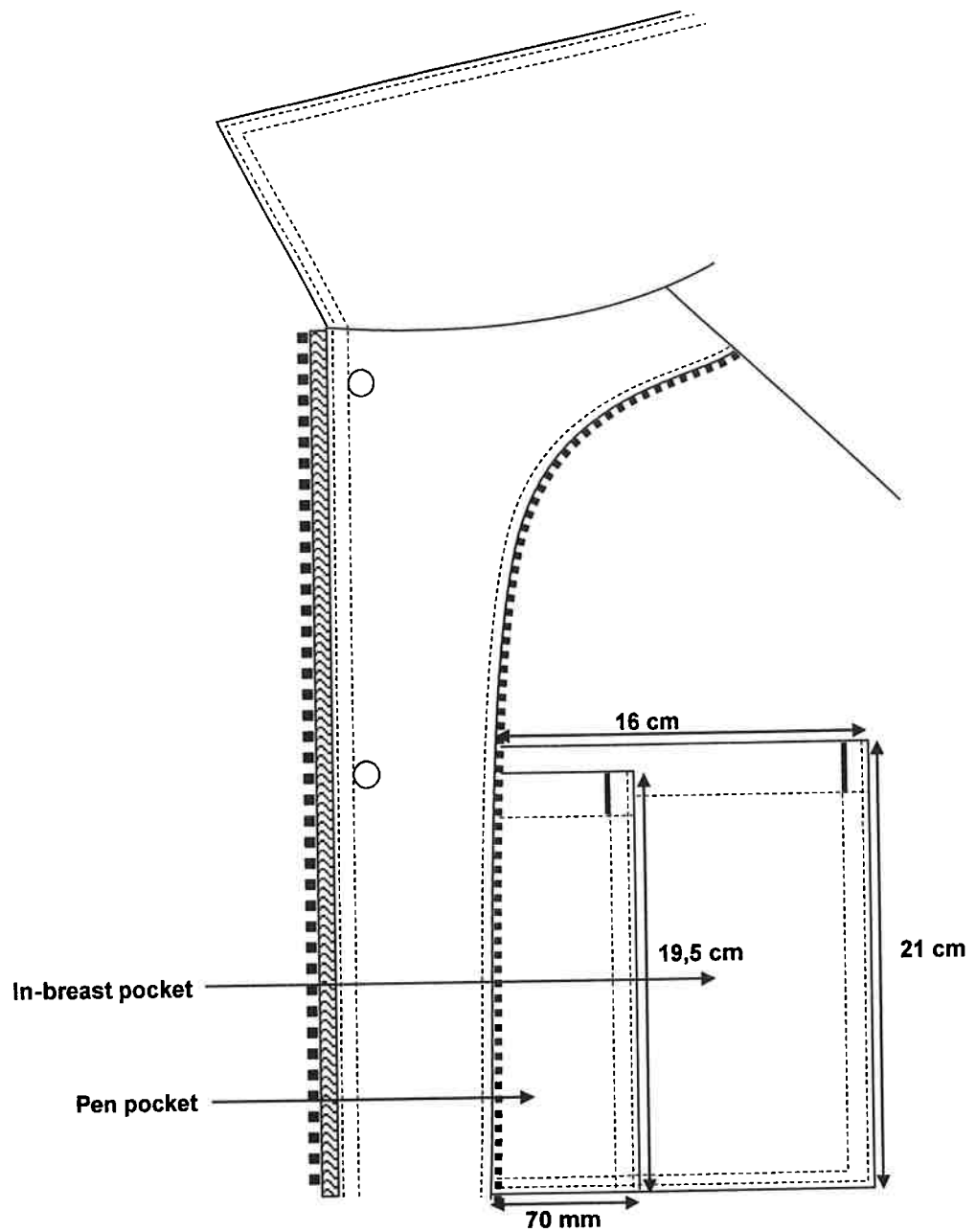

Figure 8 – Right inside

9.7 Back

Back to:

- ◆ consist of two parts:
 - **back yoke** that extends from 20 mm forward of the natural shoulder line to the back sleeve pitch point
 - **lower section**
 - to consist of a single panel
- ◆ be top-stitched 2 mm and 8 mm along the back yoke seam
- ◆ be fitted with embroidery
- ◆ be fitted with embroidery
 - embroidered with embroidery thread and centrally positioned above the back yoke seam
 - dimensions and positioning as given in figure 9

Doc No	Date	Responsibility	Version	Pages
CBCU 013	September 2016	SARS	02.0	Page 18 of 32

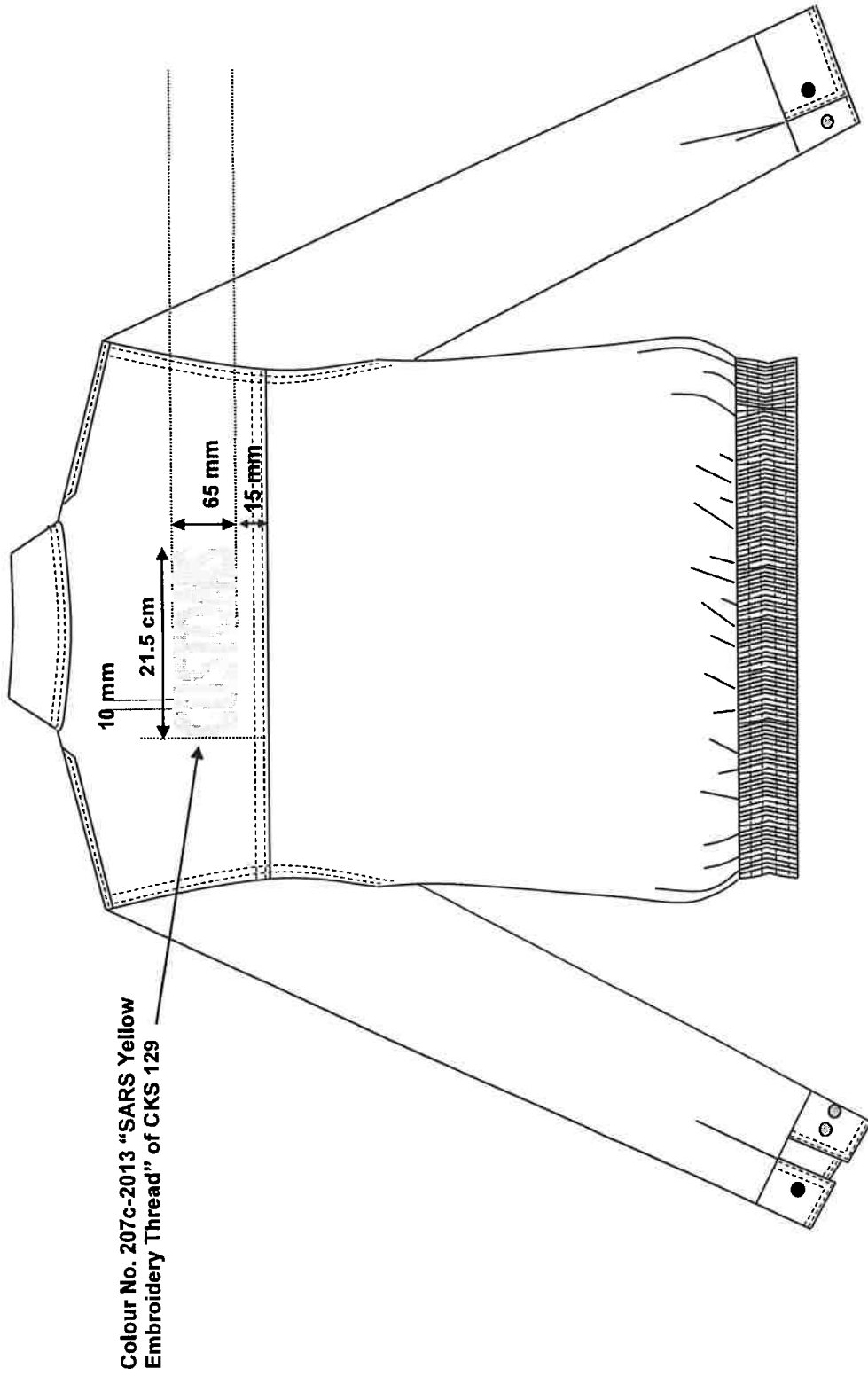

Figure 9 – Back embroidery

Doc No	Date	Responsibility	Version	Pages
CBCU 013	September 2016	SARS	02.0	Page 19 of 32

9.8 Collar

The collar to be:

- ◆ a one-piece, turned-down collar
- ◆ of outer material
- ◆ lined with outer material
- ◆ interlined with interlining
- ◆ constructed in such a way that the:
 - collar shall be of finished depth 80 mm at the centre back
 - collar shall be of finished depth 70 mm at the points
- ◆ such that it shall extend from the right front edge to the left front edge (to meet at centre front)
- ◆ edge-stitched 2 mm and 8 mm along the free edges

NOTE: Collar to form an approximate angle of 110° with the centre front edge of the jacket when laid flat (given for guidance).

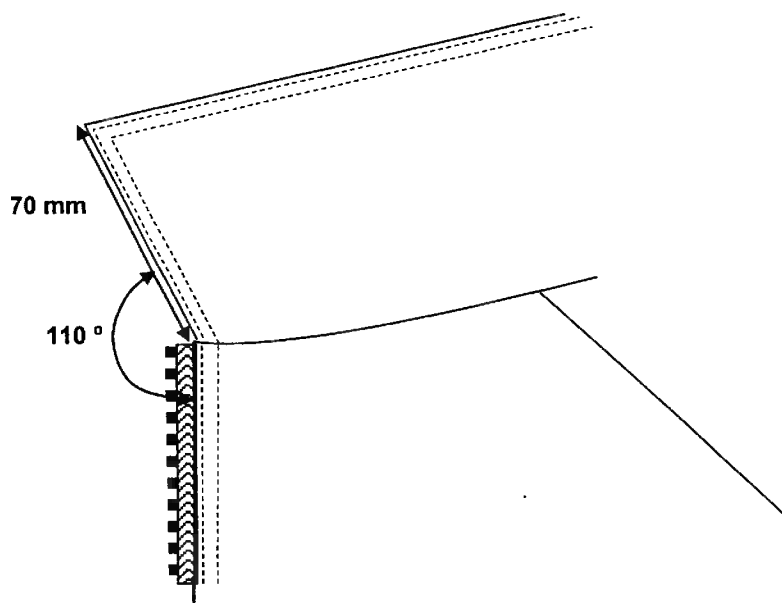

Figure 9 - Collar

9.9 Waistband

The waistband shall be:

- ◆ of finished width 50 mm
- ◆ of double folded outer material
- ◆ may be cut in one continuous length OR cut in three sections
- ◆ if cut in one continuous length, it shall be as follows (see figure 10(a))
 - fitted with a length of elastic webbing
 - rucked with 4 rows of equidistantly spaced stitchings
 - of such length that the extended measurement of the waistband shall comply with the relevant values given table 2
 - *the relaxed measurement of the waistband shall be as agreed upon between SARS and the supplier*
 - elastic to extend from 25 mm from the left front edge to 25 mm from the right front edge of the jacket
 - outer edges of elastic to be properly secured with two rows of vertical stitchings

Doc No	Date	Responsibility	Version	Pages
CBCU 013	September 2016	SARS	02.0	Page 20 of 32

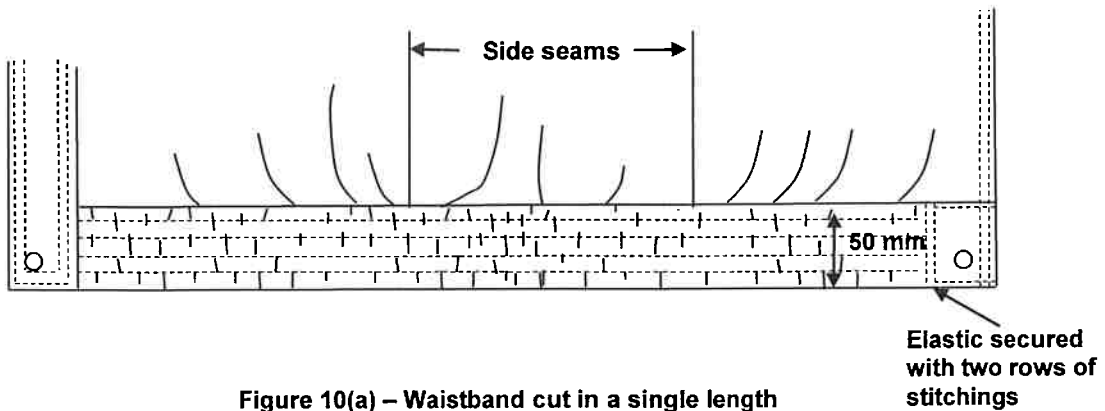

- ◆ if cut in three sections, it shall be as follows (see figure 10(b))
 - two front sections
 - plain and of finished length 25 mm
 - interlined with interlining
 - edge-stitched 2 mm along the bottom edges
 - one back section
 - to extend from the left front section seam, around the back to the right front section seam
 - fitted with a length of elastic webbing
 - ruched with 4 rows of equidistantly spaced stitchings
 - of such length that the extended measurement of the waistband shall comply with the relevant values given table 3
 - *the relaxed measurement of the waistband shall be as agreed upon between SARS and the supplier*

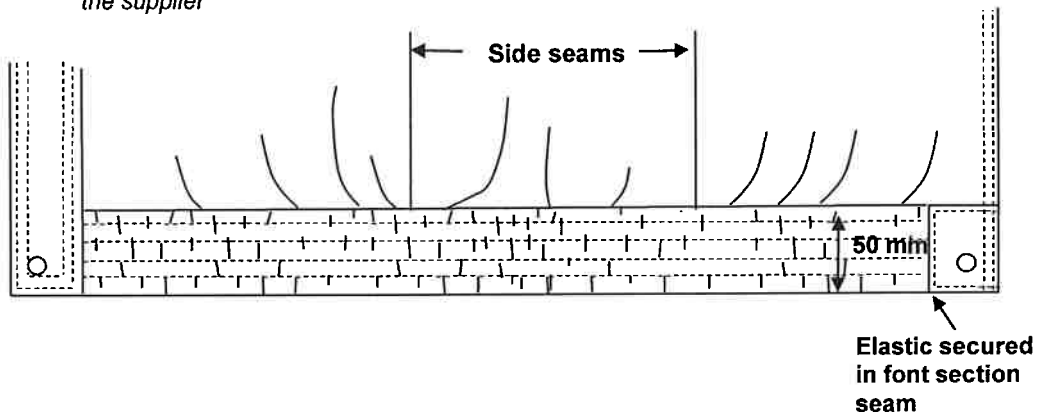

9.10 Shoulder straps

IMPORTANT NOTE: *Shoulder strap dimensions are subject to the dimensions of the shoulder boards worn with this specific item. SARS Customs shall provide sample shoulder boards to the successful bidder to manufacture shoulder straps that shall neatly accommodate the relevant shoulder insignia.*

- ◆ have mitred points
 - mitre to be of length 20 mm (measured from the base of the mitre to the point)
- ◆ be of outer material
- ◆ lined with outer material
- ◆ interlined with interlining
- ◆ be of width 50 mm at the sleeve insertion seams, tapered to 40 mm at the base of the mitre
- ◆ fasten with a press-stud fastener
- ◆ **shoulder straps to be of such length that if worn with shoulder flashes, the flashes shall lie flat against the sleeve**

Doc No	Date	Responsibility	Version	Pages
CBCU 013	September 2016	SARS	02.0	Page 21 of 32

- ◆ edge-stitched 2 mm and 8 mm along all free edges
- ◆ be sewn into the sleeve insertion seam
- ◆ fitted with a press-stud
 - female section
 - positioned centrally at the base of the mitre
 - positioned 35 mm from the body-to-collar seam (centres)
 - positioned 30 mm forward of the natural shoulder line (centres)
- ◆ positioned in such a way that when the jacket is worn:
 - the centre line of the shoulder strap shall be positioned 20 mm forward of the natural shoulder line
 - the rear edge of the strap at the sleeve seam shall be positioned 5 mm behind the natural shoulder line

Note: The shoulder seam shall be positioned 20 mm forward of the natural shoulder line.

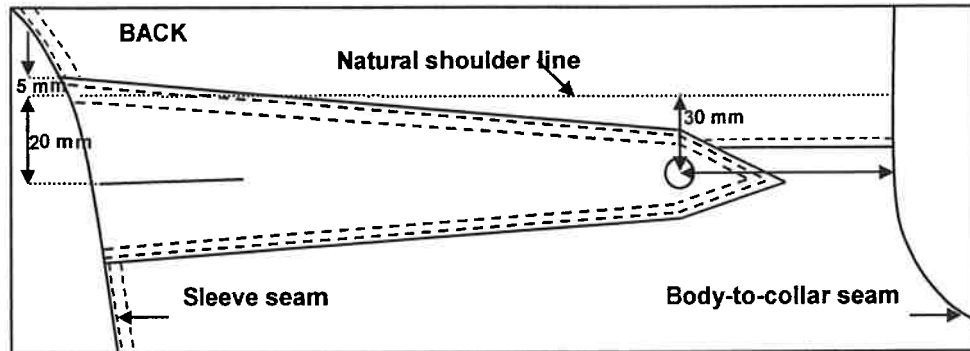

Figure 11 – Shoulder strap

9.11 Sleeves

Sleeves to:

- ◆ be long
- ◆ be one-piece
- ◆ be set-in
- ◆ seamed under the arms
- ◆ bottom edge of sleeve to be folded around the one free end of the cuff edge and tacked 10 mm to the inside of the cuff to form a pleat when it is fastened to the pres-studs
- ◆ be edge-stitched 2 mm and 8 mm along the sleeve insertion seam
- ◆ have attached cuffs
 - to be of double folded outer material
 - interlined with interlining
 - of finished width 55 mm
 - finished circumference to comply with the requirements as given in table 2
 - attached to the end of the sleeve in such a way that there shall be a 40 mm gap between the edges of the cuff
 - edge-stitched 2 mm and 8 mm around the free edges
 - each cuff to be fitted with two male pres-stud fasteners
 - two male sections and their backing sections to be attached to the under sleeve end of the cuff
 - centred in the width of the cuff
 - positioned 15 mm and 50 mm (centres) respectively from the free outer edge
 - each cuff to be fitted with one female pres-stud fastener
 - female section and it's backing section to be attached to the top sleeve end of the cuff
 - centred in the width of the cuff
 - positioned 15 mm (centres) from the free outer edge of the cuff

Doc No	Date	Responsibility	Version	Pages
CBCU 013	September 2016	SARS	02.0	Page 22 of 32

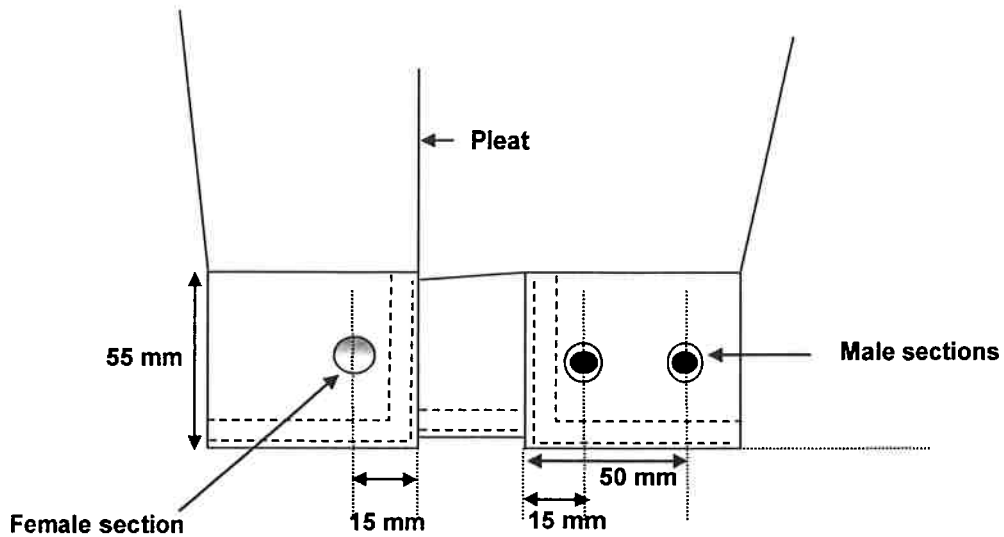

Figure 12 - Cuff

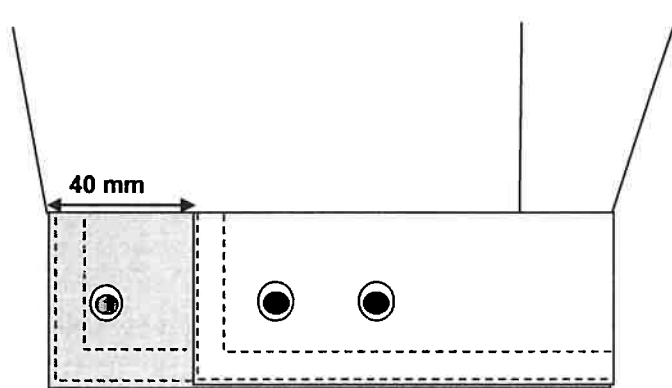

Figure 13 – Gap formed by cuff

9.12 Hanger loop

The hanger to be:

- ◆ of double folded outer material or acceptable woven tape
- ◆ of finished length 80 mm
- ◆ of width 10 mm
- ◆ securely sewn in with the collar seam at the centre back neck on the inside of the jacket

9.13 Detachable lining

The detachable lining shall:

- ◆ consist of two fronts and a single back panel
- ◆ be made from laminated fleece fabric and cut in such a way that when the detachable inner is zipped in, the polar fleece side of the fabric shall be against the wearer's body
- ◆ be sleeveless
- ◆ be such that it shall conform to the shape of the outer garment
- ◆ be 40 mm shorter than the outer jacket
- ◆ bound with bias-cut body lining strips along the armhole openings (scye), front edges, bottom edges, neck and slit for access to the inside lining pocket

Doc No	Date	Responsibility	Version	Pages
CBCU 013	September 2016	SARS	02.0	Page 23 of 32

- of finished width 12 mm -15 mm after attachment
- at the base of the scye and bottom edge of side seams to be securely tacked
- ◆ stringer of slide fastener to be attached to the outer edge of the warm lining
 - in a corresponding position to the stringer sewn to the facing-to-lining seam on the outer garment
- ◆ one front panel to have a through opening that is bound with binding tape
 - positioned in a corresponding position to the pocket mouth of the in-breast lining pocket
 - horizontal
 - to extend from the front edge of the detachable warm lining (sewn together with the binding tape along the front edge)
 - to correspond with the length of the in-breast pocket (unless not possible on small sizes)
- ◆ be fitted with an in-breast pocket and pencil pocket

In-breast pocket:

- ◆ of outer material
- ◆ to be a patch pocket
- ◆ to have square corners
- ◆ to be of finished width 17 cm
- ◆ to be of finished depth 21 cm
- ◆ positioned with the top edge of the pocket 30 mm above the base of the scye
- ◆ front edge to be sewn in with the binding
- ◆ mouth end to be vertically bar-tacked
- ◆ pocket mouth hem to be of finished width 20 mm
- ◆ side and bottom edges to be turned in 10 mm and stitched down 2 mm and 8 mm from the edges

Pen pocket:

- ◆ to be sewn on top of the in-breast patch pocket
- ◆ to be a patch pocket
- ◆ of outer material
- ◆ to have square corners
- ◆ to be of finished width 80 mm
- ◆ to be of finished depth 20 cm
- ◆ bottom edge to be aligned with the bottom edge of the in-breast pocket
- ◆ front edge to be sewn in with the binding along the free edges of the detachable warm lining
- ◆ mouth end to be vertically bar-tacked
 - pocket mouth hem to be of finished width 15 mm
 - side and bottom edges to be turned in 10 mm and stitched down 2 mm and 8 mm from the edges

Doc No	Date	Responsibility	Version	Pages
CBCU 013	September 2016	SARS	02.0	Page 24 of 32

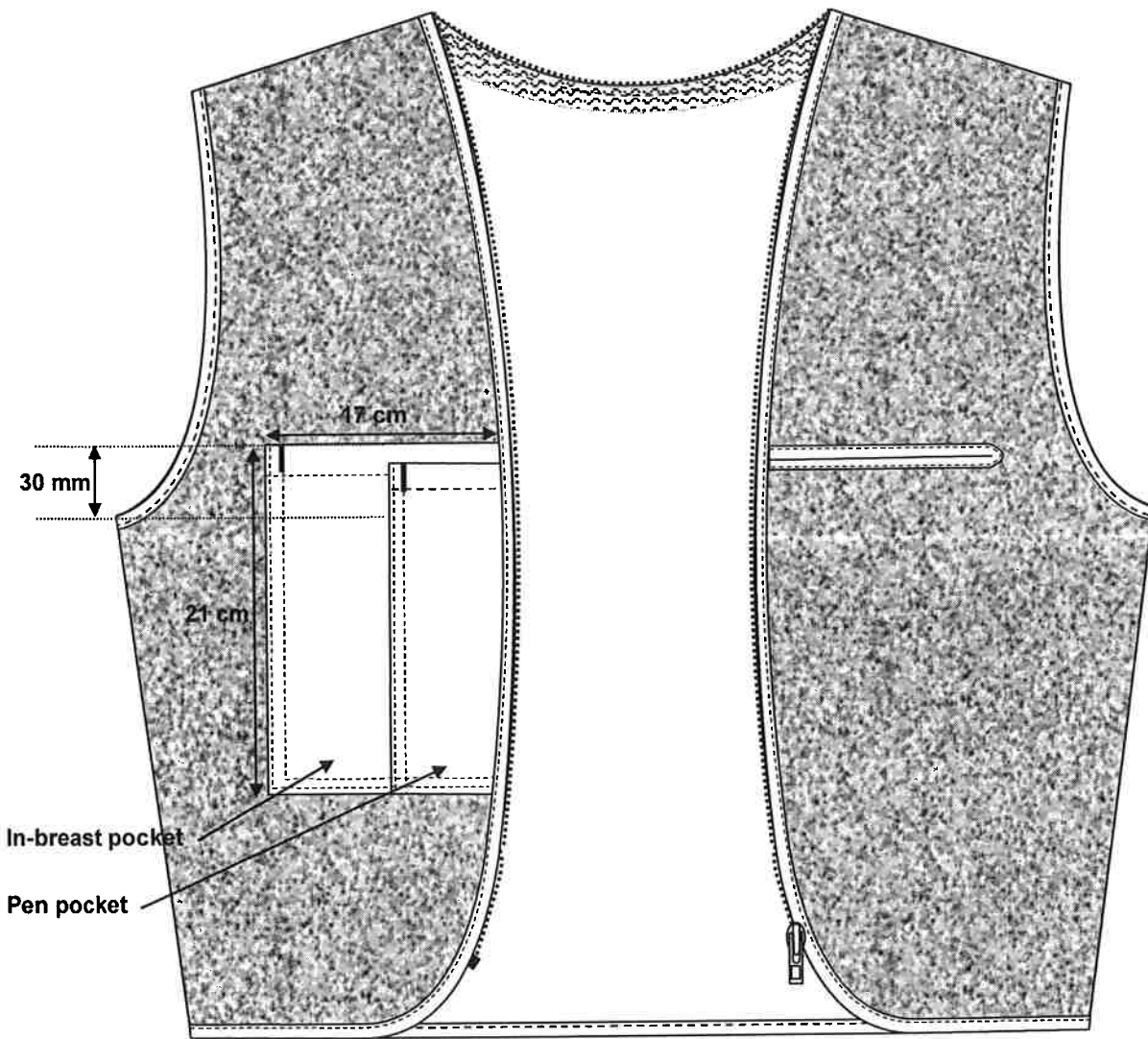

Figure 14 – Detachable warm lining

10. Stitches, Seams and Stitchings

10.1 Stitches

Main seaming of jacket: single needle lock stitch or safety stitch

Detachable warm lining seams: safety stitch

Overlocking: three-thread overlocking stitch

Other stitches: single needle lock stitch

Doc No	Date	Responsibility	Version	Pages
CBCU 013	September 2016	SARS	02.0	Page 25 of 32

10.2 Seams

Seams to be at least 10 mm wide (unless otherwise stated):

Main seams: seam type SSa-1

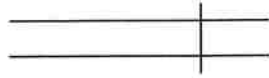

Superimpose two or more plies of material and seam with one row of stitches positioned at the specific distance(s) from the aligned edges.

Free edges of collar, cuffs and shoulder straps: seam type SSe-3

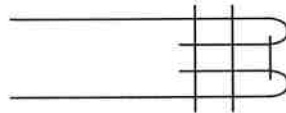

Form seam Type SSa-1, using two plies of material. Then turn back each ply at the seam and seam through the turned edges with the appropriate number of rows of stitches.

Front edges of foreparts: Seam type SSq-3

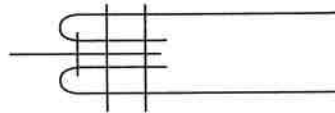

Form seam Type SSa-1, using three or more plies of material. Then turn each outer ply back at the seam and seam with the appropriate number of rows of stitches.

Attachment of in-breast and pen pockets: Seam type LSd-2

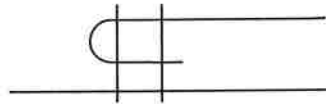

Turn in the edge of one ply of material, lap it on the body of a second ply (at the specified distance from the edge of the second ply), and seam with the appropriate number of rows of stitches.

Sleeve insertion seams and yoke seams: seam type LSq-3

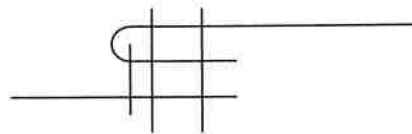

Form seam type SSa-1, using two plies of material. Then turn back the top ply at the seam and seam with the appropriate number of rows of stitches.

Attaching storm flap: seam type LSbl-3

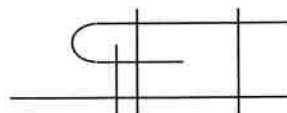

Form seam type LSbj-1. Then turn the strip back at the seam and seam with one row of stitches through the strip and ply.

Doc No	Date	Responsibility	Version	Pages
CBCU 013	September 2016	SARS	02.0	Page 26 of 32

Edges of detachable warm lining: Seam type BSc-1

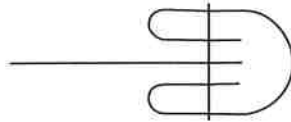

Turn in both edges of a binding strip, fold it round the edge of a ply or plies of material, and seam with the appropriate number of rows of stitches.

10.3 Stitchings

Patch pocket mouth hems: stitching type Efb

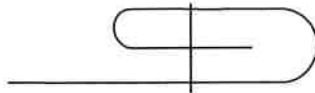

Turn in the specified width at the edge of a ply of material, fold back the turned edge, and stitch the turned-in and folded portion with the appropriate number of rows of stitches.

All exposed raw edges: stitching type Efd



Stitch over the edge of a ply of material with one row of stitches.

10.4 Number of stitches

The determination of sewing stitches per unit length: use SANS 5278 "Sewing stitches per unit length"

all seams and top-stitching: 40 ± 2 per 10 cm

11. Garment labels

11.1 Label identification

Each garment shall be fitted with the labels as given in table 3

Table 3 – Label identification

Type		Requirements
1.	a woven jacquard label	See 11.2
2.	a printed size label	See 11.3
3.	a care-label	See 11.4

11.2 Jacquard label

Each label shall:

- ◆ be a woven jacquard label with edges to be properly finished to prevent fraying
- ◆ be soft to prevent it from scratching the wearer

Doc No	Date	Responsibility	Version	Pages
CBCU 013	September 2016	SARS	02.0	Page 27 of 32

- ◆ permanently secured and sewn to the back lining **and** detachable inner on the inside at centre back
- ◆ dimensions to be as agreed upon between the South African Revenue Service and the successful tenderer
 - include the registered full-colour South African Revenue Service logo in the centre of label (see figure 15)

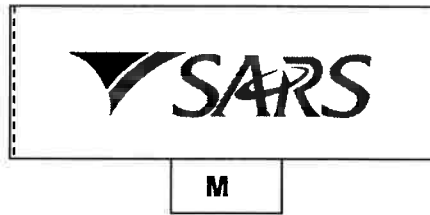

Figure 15 – Jacquard label and attached printed size label

11.3 Printed size labels

Each label shall:

- ◆ be a woven rayon label that is printed
- ◆ comply with SANS 1309 "Printed labels for textiles"
 - information to be in legible and indelible block letters of height at least 3 mm
- ◆ permanently secured below the jacquard label
- ◆ be such that they outlast the garments (including the markings)
- ◆ include the following information:
 - the size designation (see figure 15)

11.4 Printed care-labelling

Each label shall:

- ◆ be white woven rayon loop label that is printed
- ◆ comply with SANS 1309 "Printed labels for textiles"
 - information to be in legible and indelible block letters of height at least 3 mm
- ◆ be sewn in with the side seam
- ◆ be such that they outlast the garments (including the markings)
- ◆ to provide appropriate care instructions (in accordance with SANS 10011 "Care-labelling of textile piece-goods, textile articles and clothing") in words and symbols
- ◆ provide the fibre composition of the fabric in accordance with the requirements of SANS 10235 "Fibre content labelling of textiles and textile products"
- ◆ provide the year of manufacture
- ◆ provide the manufacturer's name or trade mark
- ◆ provide the VAT no of the contractor
- ◆ provide the country of origin, e.g. "Made in the RSA"
- ◆ the word "MEN"

12. Packaging and marking of packaging

12.1 Packing

12.1.1 The jackets shall be:

NOTE: *Supplier to remove all sobar labelling on the garments before delivery.*

- ◆ delivered in a commercially dry condition

Doc No	Date	Responsibility	Version	Pages
CBCU 013	September 2016	SARS	02.0	Page 28 of 32

- ◆ so packed that they will not be damaged in transit or in storage
- ◆ neatly pressed and individually packed in a plastics envelope of suitable size and shape
- ◆ unless otherwise specified in the order or contract, acceptably packed for transportation in acceptable bulk containers

12.1.2 Contents of bulk container:

- ◆ jackets intended for personnel of a specific province (e.g. Gauteng) shall be packed together in a bulk container (if relevant and as agreed upon between the SARS and the successful bidder)

12.2 Marking

12.2.1 Plastics envelopes

Each envelope to be clearly marked with the following information:

- ◆ the item description
- ◆ the size designation
- ◆ the province name, e.g. "GAUTENG" (if relevant)
- ◆ the PERSAL NUMBER of the wearer that correlates with the PERSAL NUMBER on the embossed badge

12.2.2 Bulk containers

Each bulk container shall have a label securely attached to the outside. This label shall be visible when the containers are stacked and shall provide the information in legible and indelible markings as follows:

- ◆ the province name, e.g. "GAUTENG" (if relevant)
- ◆ the manufacturer's name or trade mark or both
- ◆ the order number or contract number
- ◆ the item description
- ◆ the quantity of the item
- ◆ the year of manufacture
- ◆ the invoice number(s)
- ◆ the total mass of the packed container
- ◆ the SABS Inspection Certificate Number (if relevant)
- ◆ number of bulk containers per province, e.g. 1 of 10
- ◆ a list of all the PERSAL NUMBERS and correlating names of the intended wearers

In addition to the above, a duplicated list of the persal numbers and correlating names of the wearers shall be placed on the inside of the bulk container (if relevant).

12.3 Additional marking

When so required by the South African Revenue Service, jackets, envelopes or containers (or any combination of these) to bear information additional to that specified above.

Doc No	Date	Responsibility	Version	Pages
CBCU 013	September 2016	SARS	02.0	Page 29 of 32

13. Normative References

The following standard documents contain provisions which, through reference in this text, constitute provisions of this specification. All documents are subject to revision and, since any reference to a document is deemed to be a reference to the latest edition of a standard, parties to agreements based on this specification are encouraged to take steps to ensure the use of the most recent editions of the standards indicated below. Information on currently valid national and international standards may be obtained from SABS Standards Division.

AATCC test method 20, *Fiber analysis: Qualitative*. Available from World Wide Web http://www.aatcc.org/Technical/Test_Methods/scopes/tm20.cfm

CKS 129, *Colours for textiles*.

CKS 627, *Fusible interlinings*.

SANS 79, *Textiles – Mass per unit area of conditioned fabrics*.

SANS 105-B02/ISO 105-B02, *Textiles – Tests for colour fastness – Part B02: Colour fastness to artificial light: Xenon arc fading lamp test*.

SANS 105-C10:2006/ISO 105-C10, *Textiles – Tests for colour fastness – Part C10: Colour fastness to washing with soap or soap and soda*.

SANS 105-E04/ISO 105-E04, *Textiles – Tests for colour fastness – Part E04: Colour fastness to perspiration*.

SANS 142, *Narrow elastic fabric and strip*.

SANS 960, *Textiles - Dimensional stability during washing and drying procedures*.

SANS 1309, *Printed labels for textiles*.

SANS 1362, *Sewing threads*.

SANS 1387-7, *Woven cotton and similar apparel fabrics – Part 7: Jacket linings*.

SANS 1387-11, *Woven cotton and similar apparel fabrics – Part 11: Polyester-and-cellulosic raincoat fabrics*.

SANS 1822, *Slide fasteners*.

SANS 5278, *Sewing stitches per unit length*.

SANS 5726, *Seaming properties of woven textile fabrics*.

SANS 6116, *Resistance of textile fabrics to pilling and fuzzing (Random tumble method)*.

SANS 10011, *Care-labelling of textile piece-goods, textile articles and clothing*.

SANS 10076-1, *The assessment of defects in textile piece-goods and made-up articles – Part 1: Defects in woven piece-goods (cellulosic and cellulosic blends)*.

SANS 10235, *Fibre-content labelling of textiles and textile products*.

SANS 10371, *Terms and definitions for clothing*.

Doc No	Date	Responsibility	Version	Pages
CBCU 013	September 2016	SARS	02.0	Page 30 of 32

ANNEX A

(Normative)

Special conditions of tender

A-1 GENERAL

- A-1.1** Unless otherwise stated, SARS (or an organization deputed by it) shall be the inspecting authority.
- A-1.2** Three pre-production sample jackets, shall have been inspected, tested and approved by the inspecting authority before bulk production is commenced. Each one of these sample jackets shall be accompanied by a trim chart containing a sample of each component material (as given in 6) and the relevant conformance certificates (including the outer material). It shall be the duty of the manufacturer to give adequate notice to the inspecting authority of the availability of these samples.
- A-1.3** The jackets shall be subject to inspection during the course of manufacture. The inspector shall, during normal working hours, be given all reasonable facilities for carrying out his duties and shall have the right of entry into the contractor's factory and the factory or works of any subcontractor where work on jackets supplied to this specification may be in progress
- A-1.4** The contractor shall inspect the finished jackets for compliance with the specification before submitting them to the inspecting authority for final inspection.
- A-1.5** Before acceptance, the jackets shall have been inspected and tested by the inspecting authority and found to comply with the requirements of the specification.

A-2 DOCUMENTATION

One container of each consignment shall be marked "DOCUMENTS" and in addition to the jackets, shall contain the following:

- a) The packaging slip or delivery note;
- b) where applicable the inspection certificate(s);
- c) a copy of the invoice containing the following information:
 - the order number
 - the financial authority number
 - a full description of the consignment, i.e. quantity, etc

Doc No	Date	Responsibility	Version	Pages
CBCU 013	September 2016	SARS	02.0	Page 31 of 32

ANNEX B
(Normative)
CKS 129 Colours

Due to the fact that colours can change over a period of time, any colour standard which has been registered for a period of SEVEN YEARS or more shall be considered obsolete. These standards shall then be allocated an archived status (as opposed to current status) and re-registration shall be required.

A. The following scenarios require a submission of three metres of fabric from the successful bidder:

1. A colour standard is archived.
2. First time registration is required (CKS 129 colour number does not exist).
3. Colour swatch stock at the SABS is no longer available.

B. Requirements for the submission of fabric as identified in A:

1. The colour shall be as agreed upon between the SARS Customs and the successful bidder.
2. The fabric shall be used to make new colour swatches which shall be the responsibility of the SABS.
3. The cost of the three metres of fabric shall be incorporated in the relevant tender submission.

HISTORY SHEET				
VERSION	DATE	AMENDMENTS	CHECKED	
			NAME	INIT.
01.0	January 2014	First release		
01.1	September 2015	Change colour of outer material to be black		
01.2	October 2015	Change colour back to charcoal Change labelling to align with other garment specs (jacquard labels) Change section 5 Add reference to persal numbers		
01.3	December 2015	Waistband to be fully elasticated Change waist circumference		
02.0	September 2016	Change embroidery		

Doc No	Date	Responsibility	Version	Pages
CBCU 013	September 2016	SARS	02.0	Page 32 of 32