



KZN HEALTH

# KZN Health Intranet

Search this site



HOME CORPORATE INFORMATION COMPONENTS DIRECTORY DISTRICT OFFICES HEALTH FACILITIES

KZN Health &gt; Components &gt; Supply Chain Management

## AdvertQuote



KWAZULU-NATAL PROVINCE  
HEALTH  
REPUBLIC OF SOUTH AFRICA

## Quotation Advert

Opening Date: 2021-01-27

Closing Date: 2021-02-04

Closing Time: 11:00

### INSTITUTION DETAILS

Institution Name: Benedictine hospital

Province: KwaZulu-Natal

Department or Entity: Department of Health

Division or section: Central Supply Chain Management

Place where goods / services is required: Maintenance

Date Submitted: 2021-01-27

### ITEM CATEGORY AND DETAILS

Quotation Number: ZNQ:  
Ben 359 / 20-21

Item Category: Services

Item Description:  
1. Renovation of building - Pharmacy  
2. 2GB CIBD grading allowed  
3. Document / specification attached  
3. Provide your own PPE's in a site meeting

Quantity (if supplies):

### COMPULSORY BRIEFING SESSION / SITE VISIT

Select Type: Both

Date: 2021-01-29

Time: 09H00

Venue: Sisters Lounge

QUOTES CAN BE COLLECTED FROM: Download from website

QUOTES SHOULD BE DELIVERED TO: To be deposited in the tender box next to PRO office ONLY

### ENQUIRIES REGARDING THE ADVERT MAY BE DIRECTED TO:

Name: Phakathi AA

Email: hlengiwe.mthembu@kznhealth.gov.za

Contact Number: 035 8317062

Finance Manager Name:

Gumede PN

Finance Manager Signature:

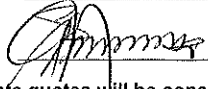

No late quotes will be considered



DESCRIPTION: **RENOVATION OF PHARMACY**

SIGNATURE OF BIDDER ..... DATE.....

[By signing this document I hereby agree to all terms and conditions]

CAPACITY UNDER WHICH THIS QUOTE IS SIGNED.....

Item No	Quantity	Description	Brand & model	Country of manufacture	Price	
					R	c
1.	Service	RENOVATION OF PHARMACY				
		NB: CIDB grading 2GB plus allowed to tender specification attached				
<b>VALUE ADDED TAX @ 15% (Only if VAT Vendor)</b>						
<b>TOTAL QUOTATION PRICE (VALIDITY PERIOD 60 Days)</b>						

Does This Offer Comply With The Specification? Is The Price Firm?	Does The Article Conform To The S.A.N.S. / S.A.B.S. Specification? State Delivery Period E.G. E.G. 1day, 1week	
--	---	--

<p><b>Enquiries regarding the <u>quote</u> may be directed to:</b></p> <p>Contact Person: <b>Phakathi AA</b> ..... Tel: <b>035 8317062</b></p> <p>E-Mail Address: <b>hlengiwe.mthembu@kznhealth.ac</b></p>	<p><b>Enquiries regarding <u>technical information</u> may be directed to:</b></p> <p>Contact Person: <b>Dlamini SB</b> ..... Tel: <b>035 8317048</b></p>
--	---

DECLARATION OF INTEREST

1. Any legal person, including persons employed by the state<sup>1</sup>, or persons having a kinship with persons employed by the state, including a blood relationship, may make an offer or offers in terms of this invitation to quote (includes a price quotation, advertised competitive quote, limited quote or proposal). In view of possible allegations of favouritism, should the resulting quote, or part thereof, be awarded to persons employed by the state, or to persons connected with or related to them, it is required that the bidder or his/her authorised representative declare his/her position in relation to the evaluating/adjudicating authority where-

- the bidder is employed by the state; and/or
- the legal person on whose behalf the bidding document is signed, has a relationship with persons/a person who are/is involved in the evaluation and or adjudication of the quote(s), or where it is known that such a relationship exists between the person or persons for or on whose behalf the declarant acts and persons who are involved with the evaluation and or adjudication of the quote.

2. In order to give effect to the above, the following questionnaire must be completed and submitted with the quote.

2.1. Full Name of bidder/representative..... 2.4. Company Registration Number: .....  
 2.2. Identity Number: ..... 2.5. Tax Reference Number: .....  
 2.3. Position occupied in the Company (director, trustee, shareholder<sup>2</sup>):..... 2.6. VAT Registration Number: .....

2.7. The names of all directors / trustees / shareholders / members, their individual identity numbers, tax reference numbers and, if applicable, employee / persal numbers must be indicated in paragraph 3 below. [TICK APPLICABLE]

2.8. Are you or any person connected with the bidder presently employed by the state? YES  NO

2.8.1. If so, furnish the following particulars:  
 Name of person / director / trustee / shareholder/ member: .....  
 Name of state institution at which you or the person connected to the bidder is employed:.....  
 Position occupied in the state institution: ..... Any other particulars:.....

2.8.2. If you are presently employed by the state, did you obtain the appropriate authority to undertake remunerative work outside employment in the public sector? YES  NO

2.8.2.1. If yes, did you attach proof of such authority to the quote document?

*(Note: Failure to submit proof of such authority, where applicable, may result in the disqualification of the quote.)*

2.8.2.2. If no, furnish reasons for non-submission of such proof: .....

2.9. Did you or your spouse, or any of the company's directors / trustees / shareholders / members or their spouses conduct business with the state in the previous twelve months? YES  NO

2.9.1. If so, furnish particulars:.....

2.10. Do you, or any person connected with the bidder, have any relationship (family, friend, other) with a person employed by the state and who may be involved with the evaluation and or adjudication of this quote? YES  NO

2.10.1. If so, furnish particulars:.....

2.11. Are you, or any person connected with the bidder, aware of any relationship (family, friend, other) between any other bidder and any person employed by the state who may be involved with the evaluation and or adjudication of this quote? YES  NO

2.11.1. If so, furnish particulars:.....

2.12. Do you or any of the directors / trustees / shareholders / members of the company have any interest in any other related companies whether or not they are bidding for this contract? YES  NO

2.12.1. If so, furnish particulars:.....

3. Full details of directors / trustees / members / shareholders.

NB: The Department Of Health will validate details of directors / trustees / members / shareholders on CSD. It is the suppliers' responsibility to ensure that their details are up-to-date and verified on CSD. If the Department cannot validate the information on CSD, the quote will not be considered and passed over as non-compliant according to National Treasury Instruction Note 4 (a) 2016/17.

4. DECLARATION

I, THE UNDERSIGNED (NAME)..... CERTIFY THAT THE INFORMATION FURNISHED IN PARAGRAPHS 2.

I ACCEPT THAT THE STATE MAY REJECT THE QUOTE OR ACT AGAINST ME SHOULD THIS DECLARATION PROVE TO BE FALSE.

Name of bidder ..... Signature ..... Position ..... Date .....

<sup>1</sup>"State" means -

- a) any national or provincial department, national or provincial public entity or constitutional institution within the meaning of the Public Finance Management Act, 1999 (Act No. 1 of 1999);
- b) any municipality or municipal entity;
- c) provincial legislature;
- d) national Assembly or the national Council of provinces; or
- e) Parliament.

<sup>2</sup>"Shareholder" means a person who owns shares in the company and is actively involved in the management of the enterprise or business and exercises control over the enterprise.

## SPECIAL CONTRACT CONDITIONS OF QUOTATIONS

### 1. AMENDMENT OF CONTRACT

- 1.1. Any amendment to or renunciation of the provisions of the contract shall at all times be done in writing and shall be signed by both parties.

### 2. CHANGE OF ADDRESS

- 2.1. Bidders must advise the Department of Health (institution where the offer was submitted) should their address (*domicilium citandi et executandi*) details change from the time of bidding to the expiry of the contract.

### 3. GENERAL CONDITIONS ATTACHED TO THIS QUOTATION

- 3.1. The institution is under no obligation to accept the lowest or any quote.
- 3.2. The price quoted must include VAT (if VAT vendor). However, it must be noted that the department reserves the right to evaluate all quotations excluding VAT as some bidders may not be VAT vendors.
- 3.3. The bidder must ensure the correctness & validity of quote:
- (i) *that the price(s), rate(s) & preference quoted cover all for the work/item (s) & accept that any mistakes regarding the price (s) & calculations will be at the bidder's risk*
- 3.4. The bidder must accept full responsibility for the proper execution & fulfillment of all obligations conditions devolving on under this agreement, as the Principal (s) liable for the due fulfillment of this contract.
- 3.5. This quotation will be evaluated based on the 80/20 points system, specification & correctness of information. All required documentation must be completed in full and submitted.
- 3.6. Offers must comply strictly with the specification.
- 3.7. Only offers that meet or are greater than the specification will be considered.
- 3.8. Late quotes will not be considered.
- 3.9. Expired product/s will not be accepted. All products supplied must be valid for a minimum period of six months.
- 3.10. A bidder not registered on the Central Suppliers Database or verification has failed will not be considered.
- 3.11. All delivery costs must be included in the quote price, for delivery at the prescribed destination.
- 3.12. Only firm prices will be accepted. Such prices must remain firm for the contract period. Non-firm prices (including rates of exchange variations) will not be considered.
- 3.13. In cases where different delivery points influence the pricing, a separate pricing schedule must be submitted for each delivery point.
- 3.14. In the event of a bidder having multiple quotes, only the cheapest according to specification will be considered. Furthermore a verification will be done to identify if bidders have multiple companies and are quoting (cover-quoting) for this bid. In such instances only the cheapest bid according to specification will be considered.

### 4. SPECIAL INSTRUCTIONS AND NOTICES TO BIDDERS REGARDING THE COMPLETION OF THIS QUOTATION.

- 4.1. Unless inconsistent with or expressly indicated otherwise by the context, the singular shall include the plural and vice versa and with words importing the masculine gender shall include the feminine and the neuter.
- 4.2. Under no circumstances whatsoever may the quotation/bid forms be retyped or redrafted. Photocopies of the original bid documentation may be used, but an original signature must appear on such photocopies.
- 4.3. The bidder is advised to check the number of pages and to satisfy himself that none are missing or duplicated.
- 4.4. Quotation submitted must be complete in all respects.
- 4.5. Any alteration made by the bidder must be initialled.
- 4.6. Use of correcting fluid is prohibited
- 4.7. Quotation will be opened in public as soon as practicable after the closing time of quotation.
- 4.8. Where practical, prices are made public at the time of opening quotations.
- 4.9. If it is desired to make more than one offer against any individual item, such offers should be given on a photocopy of the page in question. Clear indication thereof must be stated on the schedules attached.

### 5. SPECIAL INSTRUCTIONS REGARDING HAND DELIVERED QUOTATIONS

- 5.1. Quotation shall be lodged at the address indicated not later than the closing time specified for their receipt, and in accordance with the directives in the quotation documents.
- 5.2. Each quotation shall be addressed in accordance with the directives in the quotation documents and shall be lodged in a separate sealed envelope, with the name and address of the bidder, the quotation number and closing date indicated on the envelope. The envelope shall not contain documents relating to any quotation other than that shown on the envelope. If this provision is not complied with, such quotations/bids may be rejected as being invalid.
- 5.3. All quotations received in sealed envelopes with the relevant quotation numbers on the envelopes are kept unopened in safe custody until the closing time of the quotation/bids. Where, however, a quotation is received open, it shall be sealed. If it is received without a quotation/bid number on the envelope, it shall be opened, the quotation number ascertained, the envelope sealed and the quotation number written on the envelope.
- 5.4. A specific box is provided for the receipt of quotations, and no quotation found in any other box or elsewhere subsequent to the closing date and time of quotation will be considered.

### 13. PENALTIES

- 13.1. If at any time during the contract period, the service provider is unable to perform in a timely manner, the service provider must notify the institution in writing/email of the cause of and the duration of the delay. Upon receipt of the notification, the institution should evaluate the circumstances and, if deemed necessary, the institution may extend the service provider's time for performance.
- 13.2. In the event of delayed performance that extends beyond the delivery period, the institution is entitled to purchase commodities of a similar quantity and quality as a substitution for the outstanding commodities, without terminating the contract, as well as return commodities delivered at a later stage at the service provider's expense.
- 13.3. Alternatively, the institution may elect to terminate the contract and procure the necessary commodities in order to complete the contract. In the event that the contract is terminated the institution may claim damages from the service provider in the form of a penalty. The service provider's performance should be captured on the service provider database in order to determine whether or not the service provider should be awarded any contracts in the future.
- 13.4. If the supplier fails to deliver any or all of the goods or to perform the services within the period(s) specified in the contract, the purchaser shall, without prejudice to its other remedies under the contract, deduct from the contract price, as a penalty, a sum calculated on the delivered price of the delayed goods or unperformed services using the current prime interest rate calculated for each day of the delay until actual delivery or performance.

### 14. TERMINATION FOR DEFAULT

- 14.1. The purchaser, without prejudice to any other remedy for breach of contract, by written notice of default sent to the supplier, may terminate this contract in whole or in part:
  - (i) if the supplier fails to deliver any or all of the goods within the period(s) specified in the contract,
  - (ii) if the supplier fails to perform any other obligation(s) under the contract; or
  - (iii) if the supplier, in the judgment of the purchaser, has engaged in corrupt or fraudulent practices in competing for or in executing the contract.
- 14.2. In the event the purchaser terminates the contract in whole or in part, the purchaser may procure, upon such terms and in such manner as it deems appropriate, goods, works or services similar to those undelivered, and the supplier shall be liable to the purchaser for any excess costs for such similar goods, works or services.
- 14.3. Where the purchaser terminates the contract in whole or in part, the purchaser may decide to impose a restriction penalty on the supplier by prohibiting such supplier from doing business with the public sector for a period not exceeding 10 years.

### 15. FAILURE TO COMPLY WITH ABOVE WILL RESULT IN YOUR QUOTE BEING PASSED OVER.

**PREFERENCE POINTS CLAIM FORM IN TERMS OF THE PREFERENTIAL PROCUREMENT REGULATIONS 2017**

This preference form must form part of all quotes invited. It contains general information and serves as a claim form for preference points for Broad-Based Black Economic Empowerment (B-BBEE) Status Level of Contribution

**NB: BEFORE COMPLETING THIS FORM, BIDDERS MUST STUDY THE GENERAL CONDITIONS, DEFINITIONS AND DIRECTIVES APPLICABLE IN RESPECT OF B-BBEE, AS PRESCRIBED IN THE PREFERENTIAL PROCUREMENT REGULATIONS, 2017.**

**1. GENERAL CONDITIONS**

1.1 The following preference point systems are applicable to all quotes:

- the 80/20 system for requirements with a Rand value of up to R50 000 000 (all applicable taxes included); and

1.2 The value of this quote is estimated to not exceed R50 000 000 (all applicable taxes included) and therefore the 80/20 preference point system shall be applicable.

1.3 Points for this quote shall be awarded for:

- (a) Price; and
- (b) B-BBEE Status Level of Contributor.

1.4 The maximum points for this quote is allocated as follows:

	<b>POINTS</b>
<b>PRICE</b>	80
<b>B-BBEE STATUS LEVEL OF CONTRIBUTOR</b>	20
<b>Total points for Price and B-BBEE must not exceed</b>	<b>100</b>

1.5 Failure on the part of a bidder to submit proof of B-BBEE Status level of contributor together with the quote, will be interpreted to mean that preference points for B-BBEE status level of contribution are not claimed.

1.6 The purchaser reserves the right to require of a bidder, either before a quote is adjudicated or at any time subsequently, to substantiate any claim in regard to preferences, in any manner required by the purchaser.

**2. DEFINITIONS**

- (a) **"B-BBEE"** means broad-based black economic empowerment as defined in section 1 of the Broad-Based Black Economic Empowerment Act;
- (b) **"B-BBEE status level of contributor"** means the B-BBEE status of an entity in terms of a code of good practice on black economic empowerment, issued in terms of section 9(1) of the Broad-Based Black Economic Empowerment Act;
- (c) **"bid"** means a written offer in a prescribed or stipulated form in response to an invitation by an organ of state for the provision of goods or services, through price quotations, advertised competitive bidding processes or proposals;
- (d) **"Broad-Based Black Economic Empowerment Act"** means the Broad-Based Black Economic Empowerment Act, 2003 (Act No. 53 of 2003);
- (e) **"EME"** means an Exempted Micro Enterprise in terms of a code of good practice on black economic empowerment issued in terms of section 9 (1) of the Broad-Based Black Economic Empowerment Act;
- (f) **"functionality"** means the ability of a tenderer to provide goods or services in accordance with specifications as set out in the tender documents.
- (g) **"prices"** includes all applicable taxes less all unconditional discounts;
- (h) **"proof of B-BBEE status level of contributor"** means:
  - 1) B-BBEE Status level certificate issued by an authorized body or person;
  - 2) A sworn affidavit as prescribed by the B-BBEE Codes of Good Practice;
  - 3) Any other requirement prescribed in terms of the B-BBEE Act;
- (i) **"QSE"** means a qualifying small business enterprise in terms of a code of good practice on black economic empowerment issued in terms of section 9 (1) of the Broad-Based Black Economic Empowerment Act;
- (j) **"rand value"** means the total estimated value of a contract in Rand, calculated at the time of bid-invitation, and includes all applicable taxes;



**3. POINTS AWARDED FOR PRICE**

**3.1 THE 80/20 PREFERENCE POINT SYSTEMS**

A maximum of 80 points is allocated for price on the following basis:

$$Ps = 80 \left( 1 - \frac{Pt - P \min}{P \min} \right) \text{ Where}$$

- Ps = Points scored for price of bid under consideration
- Pt = Price of bid under consideration
- Pmin = Price of lowest acceptable bid

**4. POINTS AWARDED FOR B-BBEE STATUS LEVEL OF CONTRIBUTOR**

4.1 In terms of Regulation 6 (2) and 7 (2) of the Preferential Procurement Regulations, preference points must be awarded to a bidder for attaining the B-BBEE status level of contribution in accordance with the table below:

B-BBEE Status Level of Contributor	Number of points (80/20 system)
1	20
2	18
3	14
4	12
5	8
6	6
7	4
8	2
Non-compliant contributor	0

**5. BID DECLARATION**

5.1 Bidders who claim points in respect of B-BBEE Status Level of Contribution must complete the following:

**6. B-BBEE STATUS LEVEL OF CONTRIBUTOR CLAIMED IN TERMS OF PARAGRAPHS 1.4 AND 4.1**

6.1 B-BBEE Status Level of Contributor: = .....(maximum of 20 points)

(Points claimed in respect of paragraph 7.1 must be in accordance with the table reflected in paragraph 4.1 and must be substantiated by relevant proof of B-BBEE status level of contributor.

**7. SUB-CONTRACTING**

(Tick applicable box)

7.1 Will any portion of the contract be sub-contracted?

YES	<input type="checkbox"/>	NO	<input type="checkbox"/>
-----	--------------------------	----	--------------------------

7.1.1 If yes, indicate:

- i) What percentage of the contract will be subcontracted.....%
- ii) The name of the sub-contractor.....
- iii) The B-BBEE status level of the sub-contractor.....

8. Whether the sub-contractor is an EME or QSE

(Tick applicable box)

iv) Specify, by ticking the appropriate box, if subcontracting with an enterprise in terms of Preferential Procurement Regulations, 2017:

YES	<input type="checkbox"/>	NO	<input type="checkbox"/>
-----	--------------------------	----	--------------------------

Designated Group: An EME or QSE which is at last 51% owned by:	EME	QSE
Black people	√	√
Black people who are youth		
Black people who are women		
Black people with disabilities		
Black people living in rural or underdeveloped areas or townships		
Cooperative owned by black people		
Black people who are military veterans		
OR		
Any EME		
Any QSE		

9. DECLARATION WITH REGARD TO COMPANY/FIRM

9.1 Name of company/firm:.....

9.2 VAT registration number:.....

9.3 Company registration number:.....

9.4 TYPE OF COMPANY/ FIRM [TICK APPLICABLE BOX]

- Partnership/Joint Venture / Consortium
- One person business/sole propriety
- Close corporation
- Company
- (Pty) Limited

9.5 DESCRIBE PRINCIPAL BUSINESS ACTIVITIES

.....  
.....

9.6 COMPANY CLASSIFICATION [TICK APPLICABLE BOX]

- Manufacturer
- Supplier
- Professional service provider
- Other service providers, e.g. transporter, etc.

9.7 Total number of years the company/firm has been in business:.....

9.8 I/we, the undersigned, who is / are duly authorised to do so on behalf of the company/firm, certify that the points claimed, based on the B-BBE status level of contributor indicated in paragraphs 1.4 and 6.1 of the foregoing certificate, qualifies the company/ firm for the preference(s) shown and I / we acknowledge that:

- i) The information furnished is true and correct;
- ii) The preference points claimed are in accordance with the General Conditions as indicated in paragraph 1 of this form;
- iii) In the event of a contract being awarded as a result of points claimed as shown in paragraphs 1.4 and 6.1, the contractor may be required to furnish documentary proof to the satisfaction of the purchaser that the claims are correct;
- iv) If the B-BBEE status level of contributor has been claimed or obtained on a fraudulent basis or any of the conditions of contract have not been fulfilled, the purchaser may, in addition to any other remedy it may have –

- (a) disqualify the person from the bidding process;
- (b) recover costs, losses or damages it has incurred or suffered as a result of that person's conduct;
- (c) cancel the contract and claim any damages which it has suffered as a result of having to make less favourable arrangements due to such cancellation;
- (d) recommend that the bidder or contractor, its shareholders and directors, or only the shareholders and directors who acted on a fraudulent basis, be restricted by the National Treasury from obtaining business from any organ of state for a period not exceeding 10 years, after the *audi alteram partem* (hear the other side) rule has been applied; and
- (e) forward the matter for criminal prosecution.

<b>WITNESSES</b>
1. ....
2. ....

..... <b>SIGNATURE(S) OF BIDDERS(S)</b>
DATE: .....
ADDRESS..... ..... .....



**health**

Department:  
Health  
PROVINCE OF KWAZULU-NATAL

*FIGHTING DISEASE, FIGHTING POVERTY, GIVING HOPE*

**PAINTING OF WALLS, REPLACING OF VINYL SHEET  
ALSO INSTALLATION OF 2 MAIN CODED DOORS  
(RENOVATION) IN PHARMACY.**

**(TECHNICAL SPECIFICATIONS)**

**Artisan Painter: B.M. MBATHA**

**Foreman: S.B. Dlamini (Hospital Foreman)**

**Institution : Benedictine Hospital**

## PROJECT SPECIFICATION

The work to be carried out in terms of this section of the project comprises the supply and installation *of all the materials necessary, as per the Schedule of Rates*

### PART 1

#### 1.1. SCOPE OF WORK

- 1.1.1 Cleaning and preparation of wall for painting.
- 1.1.2 Painting of walls
- 1.1.3 Replacing of floor tiles with Vinyl sheet
- 1.1.4 Supplying and installation of 7 tier industrial shelving.

## **PAINTING OF WALLS, REPLACING OF VINYL SHEET, ALSO INSTALLATION OF 2 MAIN CODED DOORS (RENOVATION) IN PHARMACY.**

### PART 2

#### 2.1 TECHNICAL SPECIFICATION

This TECHNICAL SPECIFICATION shall be read in conjunction with all other sections of the SPECIFICATION and cognisance shall be taken of the clauses relevant to these particular renovations, whether any specific clauses are referred to or not. **NB. Contract period for this work 08 weeks.**

#### Part 3

#### 3.1 Requirements.

- 3.1.1. CIDB grading = 2GB plus
- 3.1.2. The contractor to submit Trade Test Certificate together with documents for the person who will monitor the work and will be onsite every day. (This will be considered on evaluation and awarding).
- 3.1.3. The contractor to submit work plan.
- 3.1.4. The contractor to return fully filled Bill of Quantity.
- 3.1.5. The contractor to comply with EPWP projects specification.

#### **4.1. MATERIALS:**

- 4.1.1 Proprietary materials where specified are to be of the brand specified or other approved by the Department.
- 4.1.2 All primers, emulsion paints, enamels, stains, varnishes, etc. are to comply with the relevant SANS specification. Paints, etc. shall be suitable for application on the surfaces to which they are being applied and those used externally shall be of exterior quality or suitable for exterior use. For any particular work the priming coat and subsequent coats of paint are to be executed with paints from the same manufacturer and in accordance with that manufacturer's instructions.
- 4.1.3 The materials are to be brought to the site in unopened containers and no adulteration will be permitted, except thinners of a quantity and quality directed by the manufacturer.
- 4.1.4 The Department shall at all times be permitted to take samples for testing purposes from open containers of any brand of paint being used on the work.
- 4.1.5 All materials, if and when required by the Department, will be subject to tests by the South African Bureau of Standards, and the cost of such tests, should the material under test not meet the requirements of this specification, shall be borne by the Contractor. Fillers and stoppings are to be suitable for use with the material being filled or stopped and to the approval of the Department.

#### **4.2. PREPARATORY WORK:**

- 4.2.1 All new and existing surfaces are to be thoroughly dry and are to be cleaned of all dust, dirt, grease, oil, rust, scale, efflorescence, fungus, loose or flaking material, etc. rubbed down, stopped, filled, knotted and sanded smooth as required in accordance with the paint manufacturer's recommendations and to the approval of the Department prior to the application of paint, etc.
- 4.2.2 Asbestos cement shall be primed with an approved alkali resistant primer before the application of subsequent coats which are not, in themselves, alkali resistant.
- 4.2.3 Iron, steel and other ferrous metals shall be cleaned in accordance with SANS Code of Practice 064 to remove rust, scale, grease, oil, etc. and the surface brought to a bright metallic condition. Galvanized iron and zinc shall be cleaned in accordance with SANS Code of Practice 062 to remove the manufacturer's temporary protective coating, white rust, etc.
- 4.2.4 Other non-ferrous metals shall be thoroughly cleaned to remove all milling oils, temporary protective coatings, etc. and the surface abraded with fine water-paper and white spirit.
- 4.2.4 Woodwork to be painted shall have all knots and resinous areas treated with an approved knotting, the surface shall then be primed and all holes, etc. stopped and rubbed down smooth,
- 4.2.5 Woodwork to be oiled, stained, varnished, etc. shall be free of all stains, pencil marks and other surface discolorations and all holes, etc. stopped with tinted stopping and rubbed down smooth.
- 4.2.6 In preparing existing glazed sashes and sash doors, all loose putty is to be removed, the rebates primed and glass re-sprigged and re-puttied as necessary before the painting is commenced.

- 4.2.7 Previously distempered or lime washed surfaces to receive any other type of paint, are to have the existing distemper or lime wash completely removed by scraping or wire brushing and the surfaces treated with an approved bonding liquid.
- 4.2.8 Where existing paint film are in good condition any flaking or bared patches are to be properly feathered into the surrounding paint and spot primed as necessary.
- 4.2.9 Where existing paint films are in poor condition and require to be removed completely, they are to be removed by means of wire brushing, paint remover, burning off, or other approved method.
- 4.2.10 Paint removers shall be free of wax and caustic substances and shall preferably be of water rinse able type. When burning off paint from wood, care must be taken to avoid charring the wood.
- 4.2.11 The final state of preparatory work to existing decorated surfaces shall in all cases produce in the finished decorated surfaces a condition similar to new work.
- 4.2.12 The Contractor will be held responsible for the proper and adequate preparation of the surfaces and any work which fails to meet the manufacturer's recommendations must be made good at the Contractor's expense to the satisfaction of the Department.

### **4.3. APPLICATION OF PAINTS, ETC.**

- 4.3.1 Painting may be carried out by brush, roller or spray as recommended by the manufacturer and to the approval of the Department. All paints, etc. are to be applied in strict accordance with the manufacturer's instructions. Each coat of paint is to be adequately and permanently keyed onto the previous coat or surface and shall be evenly distributed and continuous and shall dry to a smooth film, free from sags, runs or other imperfections. Each coat of paint is to be of a colour distinctive from previous or succeeding coats.
- 4.3.2 All painting must be done in accordance with a colour scheme which will be provided by the Department and rates for painting etc. are to include for all cutting in of contrasting colours and masking as required. No distinction has been made where more than one colour of the same material is required on the walls or ceiling of the same room.
- 4.3.3 Samples of colours for the final coats are to be prepared in all cases to the approval of the Department and all work must be finished to the approved colours.
- 4.3.4 Backs of wood door and similar frames and the surfaces of other new or prefixed joinery in contact with brickwork, etc. and built in as the work proceeds, shall be primed or sealed before building in to prevent moisture seeping into the wood from the mortar bedding.
- 4.3.5 Tongued and grooved and rebated edges of boards in batten doors and other such like inaccessible parts of new joinery shall, before assembly, be primed, or where the joinery is to receive a finish other than paint, be given one coat of such other finishing material.

4.3.6 All new external structural timbers shall be primed before the timbers are fixed in position and shall include all surfaces such as backs of fascia's and barge boards.

**4.4. PAINTWORK TO PREVIOUSLY PAINTED PREPARATORY WORK EXISTING SURFACES**

4.4.1 All previously painted surfaces must be sanded and thoroughly washed down and allowed to dry completely before paints is applied. Blistering or peeling shall be completely removed and cracks shall be opened, filled with suitable filler and finished smooth.

4.4.2 Previously painted metal surface shall be thoroughly rubbed and cleaned down. Blistered or peeling shall be completely removed.

4.4.3 Previously painted wood surface shall be thoroughly cleaned down, Blistered or peeling paint shall be peeling paint shall be completely removed and cracks and crevices shall be primed, filled with suitable filler and finished smooth.

**4.5. RATES:**

4.5.1 Rates for painting, etc. are to include for all preparatory work, and where spraying is employed, are to include or adequately masking all surrounding areas.

4.5.2 Where diameters of pipes are stated these are the nominal internal diameters, and rates for painting pipes are to include for painting the holder bats, hangers, clips, etc. supporting the pipes.

4.5.3 Rates are to include for providing all necessary dust sheets, covers, etc. taking all necessary precautions to prevent marking the surfaces of joinery, walls, floors, glass, electrical fittings, etc. All surfaces disfigured or otherwise damaged shall be completely renovated or replaced as necessary to the approval of the Department at the Contractor's own expense.

**SCHEDULE OF RATES**

**5. WORK TO BE DONE AND SCHEDULE OF PRICES:  
BENEDICTINE HOSPITAL**

Item	DESCRIPTION	UNIT	QTY	RATE/UNIT		TOTAL	
				R	c	R	c
	<p><b>NOTE:</b> All rates for items contained in this Schedule of Prices must be filled <b>excluding</b> the applicable Value Added Tax. All prices shall include labour and transport. The Administration reserves the right to Negotiate prices in the Bill of Quantities</p> <ol style="list-style-type: none"> <li>1. The contractor to provide their own water and electricity</li> <li>2. The contractor is not allowed to sleep on site</li> <li>3. The contractor is not allowed to work during the</li> </ol>						

	weekends 4. All rubbles must be removed and the contractor to comply with OHS Act 5. The contractor to give a safety plan and work hand in hand with Hospital safety officer(This will be considered on evaluation) 6. The contractor to bring safety plan.						
<b>INSTITUTION: BENEDICTINE HOSPITAL</b>							
<b>PROPRIETARY ARTICLES:</b> All equipment and material used in this contract shall be that which is specified or other approved by SABS.							
<b>EPWP Program</b>							
1.	Allow for complying with the Project EPWP Specification	Sum	1				
<b>Main passage PS2 (Inside painting)</b>							
1.	Prepare wall also supply and paint sure coat white undercoat SUC1.	m <sup>2</sup>	99				
2.	Supply and paint 2 coats for Cashmere 15 years product guarantee B2-2 Ocean Sault.	m <sup>2</sup>	99				
3.	Also prepare and painting of ceiling board with SABS Approved PVA.	m <sup>2</sup>	48				
<b>STORE ROOM 1 PS3(Inside painting)</b>							
1.	Prepare wall also supply and paint sure coat white undercoat SUC1.	m <sup>2</sup>	52				
2.	Supply and paint 2 coats for Cashmere 15 years product guarantee B2-2 Ocean Sault.	m <sup>2</sup>	52				
3.	Also prepare and painting of ceiling board with SABS Approved PVA.	m <sup>2</sup>	27				
4.	<b>PROCESS</b> Remove all existing floor tiles, the contractor shall carefully clean up the place and floors must be clean and free of obstacles before starting to work.  <b>LAYING:</b> All floor coverings and skirting to be laid by workmen experienced in laying the particular type of floor covering. In strict accordance with the instructions issued by the Manufacturer of the materials being used.  All adhesive must be the correct adhesives as supplied or recommended by the manufacturer of the material being used.	m <sup>2</sup>	27				



	<p>Floor sheeting : Supply and fix 2.0/2.5mm thick 1.2m wide Marley Super flex fully flexible vinyl floor sheeting manufactured to SABS Specification.</p> <p>ADHESIVE : Use Marley No 60 Acrylic Adhesive spread with notched trowel having 1.5mm x 1.5mm x 1.5mm triangular notches at 4.0mm centers at the rate of between 5.5m<sup>2</sup> and 6.5m<sup>2</sup></p> <p>WELDING RODS: Welded sheet flooring is to have the seams welded together by approved process to form the seamless floor or lining. Patterned sheet floorings are to be matched at joints. Vinyl skirting and edging strips are to be fully bonded to the backing surfaces. Marley Super flex may, 24hours after installation be welded using Marley Welding Rod.</p> <p>POLISHING: The newly laid floor should after 72hours are scrubbed with diluted neutral detergent complying with SABS825 and thoroughly rinsed. Three coats of a water based floor dressing complying with SABS 1042.</p>						
<b>STORE ROOM 2 PS4(Inside painting and vinyl sheeting)</b>							
1.	Prepare wall also supply and paint sure coat white undercoat SUC1.	m <sup>2</sup>	52				
2.	Supply and paint 2 coats for Cashmere 15 years product guarantee B2-2 Ocean Sault.	m <sup>2</sup>	52				
3.	Also prepare and painting of ceiling board with SABS Approved PVA.	m <sup>2</sup>	27				
4.	<p>PROCESS Remove all existing floor tiles, the contractor shall carefully clean up the place and floors must be clean and free of obstacles before starting to work.</p> <p>LAYING: All floor coverings and skirting to be laid by workmen experienced in laying the particular type of floor covering. In strict accordance with the instructions issued by the Manufacturer of the materials being used.</p> <p>All adhesive must be the correct adhesives as supplied or recommended by the manufacturer of the material being used.</p>	m <sup>2</sup>	27				

	<p>Floor sheeting : Supply and fix 2.0/2.5mm thick 1.2m wide Marley Super flex fully flexible vinyl floor sheeting manufactured to SABS Specification.</p> <p>ADHESIVE : Use Marley No 60 Acrylic Adhesive spread with notched trowel having 1.5mm x 1.5mm x 1.5mm triangular notches at 4.0mm centers at the rate of between 5.5m<sup>2</sup> and 6.5m<sup>2</sup></p> <p>WELDING RODS: Welded sheet flooring is to have the seams welded together by approved process to form the seamless floor or lining. Patterned sheet floorings are to be matched at joints. Vinyl skirting and edging strips are to be fully bonded to the backing surfaces. Marley Super flex may, 24hours after installation be welded using Marley Welding Rod.</p> <p>POLISHING: The newly laid floor should after 72hours are scrubbed with diluted neutral detergent complying with SABS825 and thoroughly rinsed. Three coats of a water based floor dressing complying with SABS 1042.</p>						
<b>STORE ROOM 3 PS5(Inside painting and vinyl sheeting)</b>							
1.	Prepare wall also supply and paint sure coat white undercoat SUC1.	m <sup>2</sup>	52				
2.	Supply and paint 2 coats for Cashmere 15 years product guarantee B2-2 Ocean Sault.	m <sup>2</sup>	52				
3.	Also prepare and painting of ceiling board with SABS Approved PVA.	m <sup>2</sup>	27				
4.	<p>PROCESS</p> <p>Remove all existing floor tiles, the contractor shall carefully clean up the place and floors must be clean and free of obstacles before starting to work.</p> <p>LAYING: All floor coverings and skirting to be laid by workmen experienced in laying the particular type of floor covering. In strict accordance with the instructions issued by the Manufacturer of the materials being used.</p> <p>All adhesive must be the correct adhesives as supplied or recommended by the manufacturer of the material being</p>	m <sup>2</sup>	27				

	<p>used.</p> <p>Floor sheeting : Supply and fix 2.0/2.5mm thick 1.2m wide Marley Super flex fully flexible vinyl floor sheeting manufactured to SABS Specification.</p> <p>ADHESIVE : Use Marley No 60 Acrylic Adhesive spread with notched trowel having 1.5mm x 1.5mm x 1.5mm triangular notches at 4.0mm centers at the rate of between 5.5m<sup>2</sup> and 6.5m<sup>2</sup></p> <p>WELDING RODS: Welded sheet flooring is to have the seams welded together by approved process to form the seamless floor or lining. Patterned sheet floorings are to be matched at joints. Vinyl skirting and edging strips are to be fully bonded to the backing surfaces. Marley Super flex may, 24hours after installation be welded using Marley Welding Rod.</p> <p>POLISHING: The newly laid floor should after 72hours are scrubbed with diluted neutral detergent complying with SABS825 and thoroughly rinsed. Three coats of a water based floor dressing complying with SABS 1042.</p>						
<b>STORE ROOM 4 IV FLUID PS6(Inside painting and vinyl sheeting)</b>							
1.	Prepare wall also supply and paint sure coat white undercoat SUC1.	m <sup>2</sup>	44				
2.	Supply and paint 2 coats for Cashmere 15 years product guarantee B2-2 Ocean Sault.	m <sup>2</sup>	44				
3.	Also prepare and painting of ceiling board with SABS Approved PVA.	m <sup>2</sup>	20				
4.	<p>PROCESS</p> <p>Remove all existing floor tiles, the contractor shall carefully clean up the place and floors must be clean and free of obstacles before starting to work.</p> <p>LAYING: All floor coverings and skirting to be laid by workmen experienced in laying the particular type of floor covering. In strict accordance with the instructions issued by the Manufacturer of the materials being used.</p>	m <sup>2</sup>	20				

	<p>All adhesive must be the correct adhesives as supplied or recommended by the manufacturer of the material being used.</p> <p>Floor sheeting : Supply and fix 2.0/2.5mm thick 1.2m wide Marley Super flex fully flexible vinyl floor sheeting manufactured to SABS Specification.</p> <p>ADHESIVE : Use Marley No 60 Acrylic Adhesive spread with notched trowel having 1.5mm x 1.5mm x 1.5mm triangular notches at 4.0mm centers at the rate of between 5.5m<sup>2</sup> and 6.5m<sup>2</sup></p> <p>WELDING RODS: Welded sheet flooring is to have the seams welded together by approved process to form the seamless floor or lining. Patterned sheet floorings are to be matched at joints. Vinyl skirting and edging strips are to be fully bonded to the backing surfaces. Marley Super flex may, 24hours after installation be welded using Marley Welding Rod.</p> <p>POLISHING: The newly laid floor should after 72hours are scrubbed with diluted neutral detergent complying with SABS825 and thoroughly rinsed. Three coats of a water based floor dressing complying with SABS 1042.</p>						
<b>IN PATIENT PS7(Inside painting and vinyl sheeting)</b>							
1.	Prepare wall also supply and paint sure coat white undercoat SUC1.	m <sup>2</sup>	50				
2.	Supply and paint 2 coats for Cashmere 15 years product guarantee B2-2 Ocean Sault.	m <sup>2</sup>	50				
3.	Also prepare and painting of ceiling board with SABS Approved PVA.	m <sup>2</sup>	25				
4.	<p><b>PROCESS</b> Remove all existing floor tiles, the contractor shall carefully clean up the place and floors must be clean and free of obstacles before starting to work.</p> <p><b>LAYING:</b> All floor coverings and skirting to be laid by workmen experienced in laying the particular type of floor covering. In strict accordance with the instructions issued by the Manufacturer of the materials being used.</p>	m <sup>2</sup>	25				

	<p>All adhesive must be the correct adhesives as supplied or recommended by the manufacturer of the material being used.</p> <p>Floor sheeting : Supply and fix 2.0/2.5mm thick 1.2m wide Marley Super flex fully flexible vinyl floor sheeting manufactured to SABS Specification.</p> <p>ADHESIVE : Use Marley No 60 Acrylic Adhesive spread with notched trowel having 1.5mm x 1.5mm x 1.5mm triangular notches at 4.0mm centers at the rate of between 5.5m<sup>2</sup> and 6.5m<sup>2</sup></p> <p>WELDING RODS: Welded sheet flooring is to have the seams welded together by approved process to form the seamless floor or lining. Patterned sheet floorings are to be matched at joints. Vinyl skirting and edging strips are to be fully bonded to the backing surfaces. Marley Super flex may, 24hours after installation be welded using Marley Welding Rod.</p> <p>POLISHING: The newly laid floor should after 72hours are scrubbed with diluted neutral detergent complying with SABS825 and thoroughly rinsed. Three coats of a water based floor dressing complying with SABS 1042.</p>						
5.	<p>Supplying of 2 doors 813 x 2032 x 40mm solid. 1½ pairs butt hinges. Multiple access ways for host controller. Support card, password, password and card.</p> <p><b><u>SPECIFICATION</u></b></p> <p><b>RFID Controller:</b></p> <ul style="list-style-type: none"> <li>➤ Working voltage: DC 12V±10%</li> <li>➤ Temperature: -10° C-55°C</li> <li>➤ Max User Capacity: 4000</li> <li>➤ Reading distance 5-15cm</li> <li>➤ Card type: ID Card</li> <li>➤ Size: Approx. 108 X 85 X 21mm/ 4.25 x 3.35 x 0.83"</li> </ul>	ITEM	02				

	<p><b>Electric magnetic lock:</b></p> <ul style="list-style-type: none"> <li>➤ Material: aluminium</li> <li>➤ Size: Approx. 170 x 38 x 20mm/ 6.69 x 1.50 x 0.79</li> <li>➤ Voltage: DC 12V</li> <li>➤ Working temperature:-10° C-55°C</li> <li>➤ Working humidity: 0-90%</li> <li>➤ Holding power: 280 KGS, 380KGS</li> <li>➤ Maximum card distance: 10-15cm</li> </ul> <p><b>Power supply:</b></p> <ul style="list-style-type: none"> <li>➤ DC Output: DC 12V 3A</li> <li>➤ AC Input: AC110V 240V 50-60Hz</li> <li>➤ Temperature: -20°C -65°C</li> <li>➤ Size: Approx. 113 x 68 x 33mm/ 4.45 x 68 x 1.30"</li> </ul> <p><b>Exit button:</b></p> <ul style="list-style-type: none"> <li>➤ Material plastic</li> <li>➤ Size: Approx.86 x 86mm /3.39 x 3.39"</li> <li>➤ Power rating: 3A/36V DC</li> </ul> <p><b>Package includes:</b></p> <ul style="list-style-type: none"> <li>➤ 1 x host controller</li> <li>➤ 1 x electric magnetic lock</li> <li>➤ 1 x door switch</li> <li>➤ 1 x power supply</li> <li>➤ 5 x card</li> <li>➤ 5 x key fob</li> <li>➤ 1 x screws set</li> <li>➤ 1 x user manual.</li> </ul>								
<b>STORES OFFICE PS8(Inside painting and vinyl sheeting)</b>									
1.	Prepare wall also supply and paint sure coat white undercoat SUC1.	m <sup>2</sup>	46						
2.	Supply and paint 2 coats for Cashmere 15 years product guarantee B2-2 Ocean Sault.	m <sup>2</sup>	46						
3.	Also prepare and painting of ceiling board with SABS Approved PVA.	m <sup>2</sup>	19						
4.	PROCESS Remove all existing floor tiles, the contractor shall carefully clean up the place and floors must be clean and free of	m <sup>2</sup>	19						

	<p>obstacles before starting to work.</p> <p>LAYING: All floor coverings and skirting to be laid by workmen experienced in laying the particular type of floor covering. In strict accordance with the instructions issued by the Manufacturer of the materials being used.</p> <p>All adhesive must be the correct adhesives as supplied or recommended by the manufacturer of the material being used.</p> <p>Floor sheeting : Supply and fix 2.0/2.5mm thick 1.2m wide Marley Super flex fully flexible vinyl floor sheeting manufactured to SABS Specification.</p> <p>ADHESIVE : Use Marley No 60 Acrylic Adhesive spread with notched trowel having 1.5mm x 1.5mm x 1.5mm triangular notches at 4.0mm centers at the rate of between 5.5m<sup>2</sup> and 6.5m<sup>2</sup></p> <p>WELDING RODS: Welded sheet flooring is to have the seams welded together by approved process to form the seamless floor or lining. Patterned sheet floorings are to be matched at joints. Vinyl skirting and edging strips are to be fully bonded to the backing surfaces. Marley Super flex may, 24hours after installation be welded using Marley Welding Rod.</p> <p>POLISHING: The newly laid floor should after 72hours are scrubbed with diluted neutral detergent complying with SABS825 and thoroughly rinsed. Three coats of a water based floor dressing complying with SABS 1042.</p>					
<b>TOILET PS9(Inside painting and tiling)</b>						
1.	Prepare wall also supply and paint sure coat white undercoat SUC1.	m <sup>2</sup>	7			
2.	Supply and paint 2 coats for Cashmere 15 years product guarantee B2-2 Ocean Sault.	m <sup>2</sup>	7			
3.	Also prepare and painting of ceiling board with SABS Approved PVA.	m <sup>2</sup>	2.4			
4.	Prepare 4m x 4.2m floor also supplying and installation of GN 573 330 x 330 Johnson Granite floor tiles including 100mm	m <sup>2</sup>	2.4			

	skirting. Tile fixer 6hrs.						
<b>KITCHEN PS10(Inside painting and tiling)</b>							
1.	Prepare wall also supply and paint sure coat white undercoat SUC1.	m <sup>2</sup>	46				
2.	Supply and paint 2 coats for Cashmere 15 years product guarantee B2-2 Ocean Sault.	m <sup>2</sup>	46				
3.	Also prepare and painting of ceiling board with SABS Approved PVA.	m <sup>2</sup>	12				
<b>MANAGER'S OFFICE PS11(Inside painting and tiling)</b>							
1.	Prepare wall also supply and paint sure coat white undercoat SUC1.	m <sup>2</sup>	36				
2.	Supply and paint 2 coats for Cashmere 15 years product guarantee B2-2 Ocean Sault.	m <sup>2</sup>	36				
3.	Also prepare and painting of ceiling board with SABS Approved PVA.	m <sup>2</sup>	12				
4.	Prepare 4m x 4.2m floor also supplying and installation of GN 573 330 x 330 Johnson Granite floor tiles including 100mm skirting. Tile fixer 6hrs	m <sup>2</sup>	12				
<b>OPD Dispatch PS12(Inside painting and tiling)</b>							
1.	Prepare wall also supply and paint sure coat white undercoat SUC1.	m <sup>2</sup>	46				
2.	Supply and paint 2 coats for Cashmere 15 years product guarantee B2-2 Ocean Sault.	m <sup>2</sup>	46				
3.	Also prepare and painting of ceiling board with SABS Approved PVA.	m <sup>2</sup>	19				
4.	<p><b>PROCESS</b> Remove all existing floor tiles, the contractor shall carefully clean up the place and floors must be clean and free of obstacles before starting to work.</p> <p><b>LAYING:</b> All floor coverings and skirting to be laid by workmen experienced in laying the particular type of floor covering. In strict accordance with the instructions issued by the Manufacturer of the materials being used.</p> <p>All adhesive must be the correct adhesives as supplied or recommended by the manufacturer of the material being used.</p>	m <sup>2</sup>	19				



	<p>Floor sheeting : Supply and fix 2.0/2.5mm thick 1.2m wide Marley Super flex fully flexible vinyl floor sheeting manufactured to SABS Specification.</p> <p>ADHESIVE : Use Marley No 60 Acrylic Adhesive spread with notched trowel having 1.5mm x 1.5mm x 1.5mm triangular notches at 4.0mm centers at the rate of between 5.5m<sup>2</sup> and 6.5m<sup>2</sup></p> <p>WELDING RODS: Welded sheet flooring is to have the seams welded together by approved process to form the seamless floor or lining. Patterned sheet floorings are to be matched at joints. Vinyl skirting and edging strips are to be fully bonded to the backing surfaces. Marley Super flex may, 24hours after installation be welded using Marley Welding Rod.</p> <p>POLISHING: The newly laid floor should after 72hours are scrubbed with diluted neutral detergent complying with SABS825 and thoroughly rinsed. Three coats of a water based floor dressing complying with SABS 1042.</p>							
--	---	--	--	--	--	--	--	--

**Supplying and installation shelving cubicle PS13**

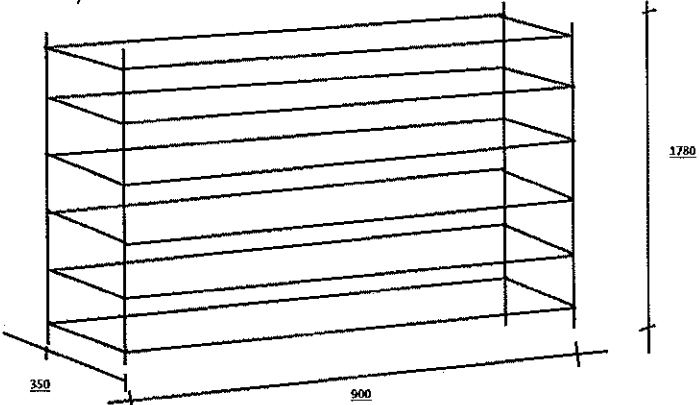
<p>1.</p>	<ul style="list-style-type: none"> <li>➤ Supplying and installation of light weight powder coated metal heavy duty 7 tier shelving units to all store rooms.</li> <li>➤ BIGDUG Garage shelving 7 level boltless storage.</li> <li>➤ Value garage shelving-flexible all-purpose boltless shelving.</li> <li>➤ Dimensions 1780mm High x 900mm Wide x 350mm Depth.</li> </ul> <p>NB. (The contractor will be advised where the installation to be made)</p> 	<p>UNI T</p>	<p>60</p>					
-----------	--	------------------	-----------	--	--	--	--	--

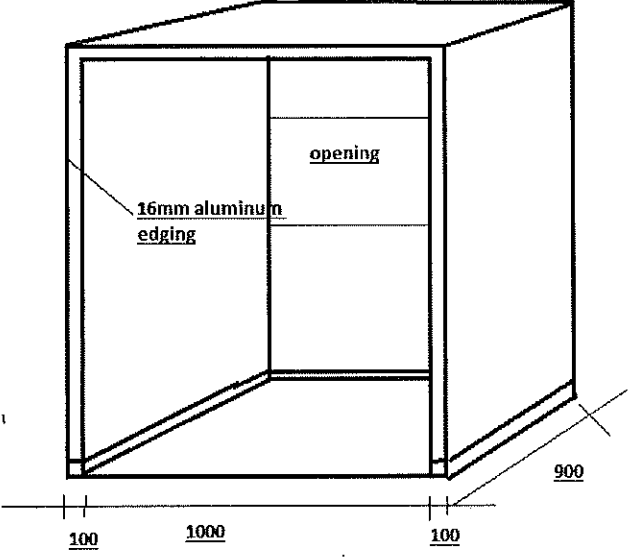
2.	<p>Contractor to supply and build pharmacy privacy counter.</p> <ul style="list-style-type: none"> <li>➤ 1 cubicle x 2300 High x 1000mm Wide x 90mm Depth using white cheap board edged with 16mm aluminium edging and 75mm aluminium skirting.</li> </ul> 							

**COLLECTION SUMMARY**

**INSTITUTION: BENEDICTINE HOSPITAL**

**PROJECT: PAINTING OF WALLS, REPLACING OF VINYL SHEET ALSO INSTALLATION OF 2 MAIN CODED DOORS (RENOVATION) IN PHARMACY.**

**NOTE:**

**THIS COLLECTION SUMMARY MUST BE COMPLETED IN FULL BY THE CONTRACTOR AND RETURNED TOGETHER WITH THE TENDER FORM.**

Collection Summary	PS 1	R					
Collection Summary	PS 2	R					
Collection Summary	PS 3	R					
Collection Summary	PS 4	R					

Collection Summary	PS 5	R		
Collection Summary	PS 6	R		
Collection Summary	PS 7	R		
Collection Summary	PS 8	R		
Collection Summary	PS 9	R		
Collection Summary	PS 10	R		
Collection Summary	PS 11	R		
Collection Summary	PS 12	R		
<b>SUB-TOTAL</b>		R		
ADD Provision for Value Added Tax. Allow 15% of SUB-TOTAL				
<b>TOTAL: CARRIED TO FORM</b>		R		