



KWAZULU-NATAL PROVINCE
HEALTH
REPUBLIC OF SOUTH AFRICA

Quotation Advert

Opening Date: 28/01/2026

Closing Date: 05/02/2026

Closing Time: 11:00

INSTITUTION DETAILS

Institution Name: Christ the King Hospital

Province: KwaZulu-Natal

Department of entity: Department of Health

Division or section: Central Supply Chain Management

Place where goods/ **Maintenance**

Services required: **CHRIST THE KING HOSPITAL**

Date Submitted: 28/01/2026

ITEM CATEGORY AND DETAILS

Quotation number: CTK138/25/26

Item Category: Services

Item Description: Repairing of aluminium doors

Quantity (if supplies): As per Quotation

COMPULSORY BRIEFING SESSION /SITE VISIT

Select Type: Compulsory Site Meeting

Date: 30/01/2026

Venue: Christ the King Assembly Point

QUOTES CAN BE COLLECTED FROM: Download from KZN Health Website

QUOTATION MUST BE DEPOSITED ON THE TENDER BOX SITUATED NEXT TO MAIN GATE AT CHRIST THE KING HOSPITAL ,BEFORE THE CLOSING TIME ANAD DATE.

ENQUIRIES REGARDING ADVERT MAY BE DIRECTED TO:

Name: Mrs CP Dlamini

Email: Clementine.Hlongwa@kznhealth.gov.za

Contact number: 039 834 7519/13

Finance Manager: Mr. B.E NZIMANDE

Finance Manager Signature

OFFICIAL PRICE PAGE FOR QUOTATIONS UP TO R1 000 000

QUOTE NUMBER: ZNQ / CTK / 138 / 2025 _ 26

DESCRIPTION: REPAIRING TO ALUMINIUM DOORS

THE BELOW PREFERENCE POINTS WILL BE ALLOCATED IN COMPLIANCE WITH THE DEPARTMENTAL PREFERENCE PROCUREMENT POLICY (KNOWN AS SCM PPP):	POINTS ALLOCATED
RDP Goal: Full points allocated to promote South African owned enterprises	20

ICN NUMBER	QUANTITY	UNIT OF MEASURE	DESCRIPTION	BRAND & MODEL	COUNTRY OF MANUFACTURE	PRICE	
						R	C
01	AS PER	ITEM	REPAIRING TO ALUMINUM DOORS AT				
	SPEC		MAIN KITCHEN AND LECTURE HALL AND				
			VERANDA COVER AT PHYSIO DEPARTM				
			ENT				
			COMPULSORY SITE BRIEFING				
			Date: 30 JANUARY 2026				
			Time: 11h00				
			Venue: CHRIST THE KING - ASSEMBLY				
			POINT				
		NB	EVALUATION CRITERIA AND				
			SPECIFICATION IS ATTACHED				
		NB	ALL BID DOCUMENTS TO BE HAND				
			DELIVERED				
		NB	NO BID DOCUMENTS WILL BE				
			AVAILABLE ON SITE BRIEFING				
VALUE ADDED TAX @ 15% (Only if VAT Vendor)							
TOTAL QUOTATION PRICE (VALIDITY PERIOD 90 Days)							

DOES THIS OFFER COMPLY WITH THE SPECIFICATION? YES / NO
 IS THE PRICE FIRM? YES / NO
 DOES THE ARTICLE CONFORM TO THE S.A.N.S. / S.A.B.S. SPECIFICATION? YES / NO
 STATE DELIVERY PERIOD (E.G. 3 DAYS, 1 WEEK) _____
 NAME OF BIDDER: _____ SIGNATURE OF BIDDER: _____
 [By signing this document, I hereby agree to all terms and conditions]
 CAPACITY UNDER WHICH THIS QUOTE IS SIGNED: _____ DATE: _____



CLARITY ON DECLARATION OF INTEREST SBD 4 (a)

BIDDER NAME	
LEGISLATION ON DISCLOSURE OF INTEREST	
<p>The Public Service Act 103 of 1994 indicates in section 30(1) that "No employee shall perform or engage himself or herself to perform remunerative work outside his or her employment in the relevant department, except with the written permission of the executive authority of the department."</p> <p>Furthermore, in terms of the Public Service Regulations paragraph 13(c), "An employee shall not conduct business with any organ of state or be a director of a public or private company conducting business with an organ of state, unless such employee is in an official capacity a director of a company listed in schedule 2 and 3 of the Public Finance Management Act"</p> <p>Treasury Regulations 16A8.4 further indicates that "If a supply chain management official or other role player, or any close family member, partner or associate of such official or other role player, has any private or business interest in any contract to be awarded, that official or other role player must-(a) disclose that interest; and (b) withdraw from participating in any manner whatsoever in the process relating to that contract."</p>	
CLARITY ON HOW TO DISCLOSE	
<p>Clause 2.2 of the Bidders Disclosure (SBD4), require the bidder to disclose a relationship with any person employed by the entire KZN Department of Health, even if that person is not employed by the procuring institution. The Department may use other Computer Assisted Techniques to verify possible interest, should you be found to have failed to disclose correctly, your bid/quotation will be treated as a false declaration, treated as non-responsive and disqualified.</p> <p>For example, if the tender is advertised or invited by Addington Hospital, yet the person with interest is employed by Manguzi Hospital, as long as that official is employed by the Department of Health, the bidder is required to disclose interest. Therefore the question is, do you, or any person connected with the bidder, have a relationship with any person who is employed by the KZN Department of Health? If so, please furnish particulars on Bidders Disclosure (SBD4) section 2.2.1, as attached below,</p>	

I read the above clarity on disclosure of interest and I commit to disclose as directed, should I fail to disclose correctly, I am aware of the consequences, which may include disqualification of my offer.

BIDDER SURNAME AND INITIALS

SIGNATURE

DATE

BIDDER'S DISCLOSURE

1 PURPOSE OF THE FORM

Any person (natural or juristic) may make an offer or offers in terms of this invitation to bid. In line with the principles of transparency, accountability, impartiality, and ethics as enshrined in the Constitution of the Republic of South Africa and further expressed in various pieces of legislation, it is required for the bidder to make this declaration in respect of the details required hereunder.

Where a person/s are listed in the Register for Tender Defaulters and / or the List of Restricted Suppliers, that person will automatically be disqualified from the bid process.

2 BIDDER'S DECLARATION

2.1. Is the bidder, or any of its directors / trustees / shareholders / members / partners or any person having a controlling interest¹ in the enterprise, employed by the state? **YES / NO**

2.1.1. If so, furnish particulars of the names, individual identity numbers, and, if applicable, state employee numbers of sole proprietor/ directors / trustees / shareholders / members/ partners or any person having a controlling interest in the enterprise, in table below.

FULL NAME	IDENTITY NUMBER	NAME OF STATE INSTITUTION

2.2. Do you, or any person connected with the bidder, have a relationship with any person who is employed by the procuring institution²? **YES / NO**

2.2.1. If so, furnish particulars: _____

2.3. Does the bidder or any of its directors / trustees / shareholders / members / partners or any person having a controlling interest in the enterprise have any interest in any other related enterprise whether or not they are bidding for this contract? **YES / NO**

2.3.1. If so, furnish particulars: _____

3 DECLARATION

I, the undersigned, (name) _____ in submitting the accompanying bid, do hereby make the following statements that I certify to be true and complete in every respect:

- 3.1. I have read and I understand the contents of this disclosure;
- 3.2. I understand that the accompanying bid will be disqualified if this disclosure is found not to be true and complete in every respect;
- 3.3. The bidder has arrived at the accompanying bid independently from, and without consultation, communication, agreement or arrangement with any competitor. However, communication between partners in a joint venture or consortium³ will not be construed as collusive bidding. In addition, there have been no consultations, communications, agreements or arrangements with any competitor regarding the quality, quantity, specifications, prices, including methods, factors or formulas used to calculate prices, market allocation, the intention or decision to submit or not to submit the bid, bidding with the intention not to win the bid and conditions or delivery particulars of the products or services to which this bid invitation relates.
- 3.5. The terms of the accompanying bid have not been, and will not be, disclosed by the bidder, directly or indirectly, to any competitor, prior to the date and time of the official bid opening or of the awarding of the contract.
- 3.6. There have been no consultations, communications, agreements or arrangements made by the bidder with any official of the procuring institution in relation to this procurement process prior to and during the bidding process except to provide clarification on the bid submitted where so required by the institution; and the bidder was not involved in the drafting of the specifications or terms of reference for this bid.
- 3.7. I am aware that, in addition and without prejudice to any other remedy provided to combat any restrictive practices related to bids and contracts, bids that are suspicious will be reported to the Competition Commission for investigation and possible imposition of administrative penalties in terms of section 59 of the Competition Act No 89 of 1998 and or may be reported to the National Prosecuting Authority (NPA) for criminal investigation and or may be restricted from conducting business with the public sector for a period not exceeding ten (10) years in terms of the Prevention and Combating of Corrupt Activities Act No 12 of 2004 or any other applicable legislation.

I CERTIFY THAT THE INFORMATION FURNISHED IN PARAGRAPHS 1, 2 and 3 ABOVE IS CORRECT.

I ACCEPT THAT THE STATE MAY REJECT THE BID OR ACT AGAINST ME IN TERMS OF PARAGRAPH 6 OF PFMA SCM INSTRUCTION 03 OF 2021/22 ON PREVENTING AND COMBATING ABUSE IN THE SUPPLY CHAIN MANAGEMENT SYSTEM SHOULD THIS DECLARATION PROVE TO BE FALSE.

NAME OF BIDDER	SIGNATURE	POSITION	DATE
----------------	-----------	----------	------

¹ The power, by one person or a group of persons holding the majority of the equity of an enterprise, alternatively, the person/s having the deciding vote or power to influence or to direct the course and decisions of the enterprise.
² "Procuring Institution" refers to all institutions under the Accounting Officer of the Department of Health.
³ Joint venture or Consortium means an association of persons for the purpose of combining their expertise, property, capital, efforts, skill and knowledge in an activity for the execution of a contract.

GENERAL CONDITIONS OF CONTRACT

NOTES

The purpose of this document is to:

- (i) Draw special attention to certain general conditions applicable to government bids, contracts and orders; and
- (ii) To ensure that clients be familiar with regard to the rights and obligations of all parties involved in doing business with government.

In this document words in the singular also mean in the plural and vice versa and words in the masculine also mean in the feminine and neuter.

- The General Conditions of Contract will form part of all bid/quotation documents and may not be amended.
- Special Conditions of Contract (SCC) relevant to a specific bid, should be compiled separately for every bid (if applicable) and will supplement the General Conditions of Contract. Whenever there is a conflict, the provisions in the SCC shall prevail.

1. Definitions

The following terms shall be interpreted as indicated:

- 1.1. "Closing time" means the date and hour specified in the bidding documents for the receipt of bids.
- 1.2. "Contract" means the written agreement entered into between the purchaser and the supplier, as recorded in the contract form signed by the parties, including all attachments and appendices thereto and all documents incorporated by reference therein.
- 1.3. "Contract price" means the price payable to the supplier under the contract for the full and proper performance of his contractual obligations.
- 1.4. "Corrupt practice" means the offering, giving, receiving, or soliciting of any thing of value to influence the action of a public official in the procurement process or in contract execution.
- 1.5. "Countervailing duties" are imposed in cases where an enterprise abroad is subsidized by its government and encouraged to market its products internationally.
- 1.6. "Country of origin" means the place where the goods were mined, grown or produced or from which the services are supplied. Goods are produced when, through manufacturing, processing or substantial and major assembly of components, a commercially recognized new product results that is substantially different in basic characteristics or in purpose or utility from its components.
- 1.7. "Day" means calendar day.
- 1.8. "Delivery" means delivery in compliance of the conditions of the contract or order.
- 1.9. "Delivery ex stock" means immediate delivery directly from stock actually on hand.
- 1.10. "Delivery into consignees store or to his site" means delivered and unloaded in the specified store or depot or on the specified site in compliance with the conditions of the contract or order, the supplier bearing all risks and charges involved until the supplies are so delivered and a valid receipt is obtained.
- 1.11. "Dumping" occurs when a private enterprise abroad market its goods on own initiative in the RSA at lower prices than that of the country of origin and which have the potential to harm the local industries in the RSA
- 1.12. "Force majeure" means an event beyond the control of the supplier and not involving the supplier's fault or negligence and not foreseeable. Such events may include, but is not restricted to, acts of the purchaser in its sovereign capacity, wars or revolutions, fires, floods, epidemics, quarantine restrictions and freight embargoes.
- 1.13. "Fraudulent practice" means a misrepresentation of facts in order to influence a procurement process or the execution of a contract to the detriment of any bidder, and includes collusive practice among bidders (prior to or after bid submission) designed to establish bid prices at artificial non-competitive levels and to deprive the bidder of the benefits of free and open competition.
- 1.14. "GCC" means the General Conditions of Contract.
- 1.15. "Goods" means all of the equipment, machinery, and/or other materials that the supplier is required to supply to the purchaser under the contract.
- 1.16. "Imported content" means that portion of the bidding price represented by the cost of components, parts or materials which have been or are still to be imported (whether by the supplier or his subcontractors) and which costs are inclusive of the costs abroad, plus freight and other direct importation costs such as landing costs, dock dues, import duty, sales duty or other similar tax or duty at the South African place of entry as well as transportation and handling charges to the factory in the Republic where the supplies covered by the bid will be manufactured.
- 1.17. "Local content" means that portion of the bidding price which is not included in the imported content provided that local manufacture does take place.
- 1.18. "Manufacture" means the production of products in a factory using labour, materials, components and machinery and includes other related value-adding activities.
- 1.19. "Order" means an official written order issued for the supply of goods or works or the rendering of a service.
- 1.20. "Project site," where applicable, means the place indicated in bidding documents.
- 1.21. "Purchaser" means the organization purchasing the goods.
- 1.22. "Republic" means the Republic of South Africa.
- 1.23. "SCC" means the Special Conditions of Contract.
- 1.24. "Services" means those functional services ancillary to the supply of the goods, such as transportation and any other incidental services, such as installation, commissioning, provision of technical assistance, training, catering, gardening, security, maintenance and other such obligations of the supplier covered under the contract.
- 1.25. "Written" or "in writing" means handwritten in ink or any form of electronic or mechanical writing.

2. Application

- 2.1. These general conditions are applicable to all bids, contracts and orders including bids for functional and professional services, sales, hiring, letting and the granting or acquiring of rights, but excluding immovable property, unless otherwise indicated in the bidding documents.
- 2.2. Where applicable, special conditions of contract are also laid down to cover specific supplies, services or works.
- 2.3. Where such special conditions of contract are in conflict with these general conditions, the special conditions shall apply.

3. General

- 3.1. Unless otherwise indicated in the bidding documents, the purchaser shall not be liable for any expense incurred in the preparation and submission of a bid. Where applicable a non-refundable fee for documents may be charged.
- 3.2. With certain exceptions, invitations to bid are only published in the Government Tender Bulletin. The Government Tender Bulletin may be obtained directly from the Government Printer, Private Bag X85, Pretoria 0001, or accessed electronically from www.treasury.gov.za



4. Standards

- 4.1. The goods supplied shall conform to the standards mentioned in the bidding documents and specifications.

5. Use of contract documents and information; inspection.

- 5.1. The supplier shall not, without the purchaser's prior written consent, disclose the contract, or any provision thereof, or any specification, plan, drawing, pattern, sample, or information furnished by or on behalf of the purchaser in connection therewith, to any person other than a person employed by the supplier in the performance of the contract. Disclosure to any such employed person shall be made in confidence and shall extend only so far as may be necessary for purposes of such performance.
- 5.2. The supplier shall not, without the purchaser's prior written consent, make use of any document or information mentioned in GCC clause 5.1 except for purposes of performing the contract.
- 5.3. Any document, other than the contract itself mentioned in GCC clause 5.1 shall remain the property of the purchaser and shall be returned (all copies) to the purchaser on completion of the supplier's performance under the contract if so required by the purchaser.
- 5.4. The supplier shall permit the purchaser to inspect the supplier's records relating to the performance of the supplier and to have them audited by auditors appointed by the purchaser, if so required by the purchaser.

6. Patent rights

- 6.1. The supplier shall indemnify the purchaser against all third-party claims of infringement of patent, trademark, or industrial design rights arising from use of the goods or any part thereof by the purchaser.

7. Performance security

- 7.1. Within thirty (30) days of receipt of the notification of contract award, the successful bidder shall furnish to the purchaser the performance security of the amount specified in SCC.
- 7.2. The proceeds of the performance security shall be payable to the purchaser as compensation for any loss resulting from the supplier's failure to complete his obligations under the contract.
- 7.3. The performance security shall be denominated in the currency of the contract, or in a freely convertible currency acceptable to the purchaser and shall be in one of the following forms:
- (a) a bank guarantee or an irrevocable letter of credit issued by a reputable bank located in the purchaser's country or abroad, acceptable to the purchaser, in the form provided in the bidding documents or another form acceptable to the purchaser; or
 - (b) a cashier's or certified cheque
- 7.4. The performance security will be discharged by the purchaser and returned to the supplier not later than thirty (30) days following the date of completion of the supplier's performance obligations under the contract, including any warranty obligations, unless otherwise specified in SCC.

8. Inspections, tests and analyses

- 8.1. All pre-bidding testing will be for the account of the bidder.
- 8.2. If it is a bid condition that supplies to be produced or services to be rendered should at any stage during production or execution or on completion be subject to inspection, the premises of the bidder or contractor shall be open, at all reasonable hours, for inspection by a representative of the Department or an organization acting on behalf of the Department.
- 8.3. If there are no inspection requirements indicated in the bidding documents and no mention is made in the contract, but during the contract period it is decided that inspections shall be carried out, the purchaser shall itself make the necessary arrangements, including payment arrangements with the testing authority concerned.
- 8.4. If the inspections, tests and analyses referred to in clauses 8.2 and 8.3 show the supplies to be in accordance with the contract requirements, the cost of the inspections, tests and analyses shall be defrayed by the purchaser.
- 8.5. Where the supplies or services referred to in clauses 8.2 and 8.3 do not comply with the contract requirements, irrespective of whether such supplies or services are accepted or not, the cost in connection with these inspections, tests or analyses shall be defrayed by the supplier.
- 8.6. Supplies and services which are referred to in clauses 8.2 and 8.3 and which do not comply with the contract requirements may be rejected.
- 8.7. Any contract supplies may on or after delivery be inspected, tested or analyzed and may be rejected if found not to comply with the requirements of the contract. Such rejected supplies shall be held at the cost and risk of the supplier who shall, when called upon, remove them immediately at his own cost and forthwith substitute them with supplies which do comply with the requirements of the contract. Failing such removal the rejected supplies shall be returned at the suppliers cost and risk. Should the supplier fail to provide the substitute supplies forthwith, the purchaser may, without giving the supplier further opportunity to substitute the rejected supplies, purchase such supplies as may be necessary at the expense of the supplier.
- 8.8. The provisions of clauses 8.4 to 8.7 shall not prejudice the right of the purchaser to cancel the contract on account of a breach of the conditions thereof, or to act in terms of Clause 23 of GCC.

9. Packing

- 9.1. The supplier shall provide such packing of the goods as is required to prevent their damage or deterioration during transit to their final destination, as indicated in the contract. The packing shall be sufficient to withstand, without limitation, rough handling during transit and exposure to extreme temperatures, salt and precipitation during transit, and open storage. Packing, case size and weights shall take into consideration, where appropriate, the remoteness of the goods' final destination and the absence of heavy handling facilities at all points in transit.
- 9.2. The packing, marking, and documentation within and outside the packages shall comply strictly with such special requirements as shall be expressly provided for in the contract, including additional requirements, if any, specified in SCC, and in any subsequent instructions ordered by the purchaser.

10. Delivery and documents

- 10.1. Delivery of the goods shall be made by the supplier in accordance with the terms specified in the contract. The details of shipping and/or other documents to be furnished by the supplier are specified in SCC.
- 10.2. Documents to be submitted by the supplier are specified in SCC.

11. Insurance

- 11.1. The goods supplied under the contract shall be fully insured in a freely convertible currency against loss or damage incidental to manufacture or acquisition, transportation, storage and delivery in the manner specified in the SCC.

- 12. Transportation**
- 12.1. Should a price other than an all-inclusive delivered price be required, this shall be specified in the SCC.
- 13. Incidental services**
- 13.1. The supplier may be required to provide any or all of the following services, including additional services, if any, specified in SCC:
- (a) performance or supervision of on-site assembly and/or commissioning of the supplied goods;
 - (b) furnishing of tools required for assembly and/or maintenance of the supplied goods;
 - (c) furnishing of a detailed operations and maintenance manual for each appropriate unit of the supplied goods;
 - (d) performance or supervision or maintenance and/or repair of the supplied goods, for a period of time agreed by the parties, provided that this service shall not relieve the supplier of any warranty obligations under this contract; and
 - (e) training of the purchaser's personnel, at the supplier's plant and/or on-site, in assembly, start-up, operation, maintenance, and/or repair of the
- 13.2. Prices charged by the supplier for incidental services, if not included in the contract price for the goods, shall be agreed upon in advance by the parties and shall not exceed the prevailing rates charged to other parties by the supplier for similar services.
- 14. Spare parts**
- As specified in SCC, the supplier may be required to provide any or all of the following materials, notifications, and information pertaining to spare parts manufactured or distributed by the supplier:
- 14.1. (a) such spare parts as the purchaser may elect to purchase from the supplier, provided that this election shall not relieve the supplier of any warranty obligations under the contract; and
- (b) in the event of termination of production of the spare parts:
- (i) Advance notification to the purchaser of the pending termination, in sufficient time to permit the purchaser to procure needed requirements; and
 - (ii) following such termination, furnishing at no cost to the purchaser, the blueprints, drawings, and specifications of the spare parts, if requested.
- 15. Warranty**
- 15.1. The supplier warrants that the goods supplied under the contract are new, unused, of the most recent or current models, and that they incorporate all recent improvements in design and materials unless provided otherwise in the contract. The supplier further warrants that all goods supplied under this contract shall have no defect, arising from design, materials, or workmanship (except when the design and/or material is required by the purchaser's specifications) or from any act or omission of the supplier, that may develop under normal use of the supplied goods in the conditions prevailing in the country of final destination.
- 15.2. This warranty shall remain valid for twelve (12) months after the goods, or any portion thereof as the case may be, have been delivered to and accepted at the final destination indicated in the contract, or for eighteen (18) months after the date of shipment from the port or place of loading in the source country, whichever period concludes earlier, unless specified otherwise in SCC.
- 15.3. The purchaser shall promptly notify the supplier in writing of any claims arising under this warranty.
- 15.4. Upon receipt of such notice, the supplier shall, within the period specified in SCC and with all reasonable speed, repair or replace the defective goods or parts thereof, without costs to the purchaser.
- 15.5. If the supplier, having been notified, fails to remedy the defect(s) within the period specified in SCC, the purchaser may proceed to take such remedial action as may be necessary, at the supplier's risk and expense and without prejudice to any other rights which the purchaser may have against the supplier under the contract.
- 16. Payment**
- 16.1. The method and conditions of payment to be made to the supplier under this contract shall be specified in SCC.
- 16.2. The supplier shall furnish the purchaser with an invoice accompanied by a copy of the delivery note and upon fulfillment of other obligations stipulated in the contract.
- 16.3. Payments shall be made promptly by the purchaser, but in no case later than thirty (30) days after submission of an invoice or claim by the supplier.
- 16.4. Payment will be made in Rand unless otherwise stipulated in SCC.
- 17. Prices**
- 17.1. Prices charged by the supplier for goods delivered and services performed under the contract shall not vary from the prices quoted by the supplier in his bid, with the exception of any price adjustments authorized in SCC or in the purchaser's request for bid validity extension, as the case may be.
- 18. Contract amendments**
- 18.1. No variation in or modification of the terms of the contract shall be made except by written amendment signed by the parties concerned.
- 19. Assignment**
- 19.1. The supplier shall not assign, in whole or in part, its obligations to perform under the contract, except with the purchaser's prior written consent.
- 20. Subcontracts**
- 20.1. The supplier shall notify the purchaser in writing of all subcontracts awarded under this contracts if not already specified in the bid. Such notification, in the original bid or later, shall not relieve the supplier from any liability or obligation under the contract.
- 21. Delays in the supplier's performance**
- 21.1. Delivery of the goods and performance of services shall be made by the supplier in accordance with the time schedule prescribed by the purchaser in the contract.
- 21.2. If at any time during performance of the contract, the supplier or its subcontractor(s) should encounter conditions impeding timely delivery of the goods and performance of services, the supplier shall promptly notify the purchaser in writing of the fact of the delay, its likely duration and its cause(s). As soon as practicable after receipt of the supplier's notice, the purchaser shall evaluate the situation and may at his discretion extend the supplier's time for performance, with or without the imposition of penalties, in which case the extension shall be ratified by the parties by amendment of contract.
- 21.3. No provision in a contract shall be deemed to prohibit the obtaining of supplies or services from a national department, provincial department, or a local authority.
- 21.4. The right is reserved to procure outside of the contract small quantities or to have minor essential services executed if an emergency arises, the supplier's point of supply is not situated at or near the place where the supplies are required, or the supplier's services are not readily available.



- 21.5. Except as provided under GCC Clause 25, a delay by the supplier in the performance of its delivery obligations shall render the supplier liable to the imposition of penalties, pursuant to GCC Clause 22, unless an extension of time is agreed upon pursuant to GCC Clause 21.2 without the application of penalties.
- 21.6. Upon any delay beyond the delivery period in the case of a supplies contract, the purchaser shall, without canceling the contract, be entitled to purchase supplies of a similar quality and up to the same quantity in substitution of the goods not supplied in conformity with the contract and to return any goods delivered later at the supplier's expense and risk, or to cancel the contract and buy such goods as may be required to complete the contract and without prejudice to his other rights, be entitled to claim damages from the supplier.
- 22. Penalties**
- 22.1. Subject to GCC Clause 25, if the supplier fails to deliver any or all of the goods or to perform the services within the period(s) specified in the contract, the purchaser shall, without prejudice to its other remedies under the contract, deduct from the contract price, as a penalty, a sum calculated on the delivered price of the delayed goods or unperformed services using the current prime interest rate calculated for each day of the delay until actual delivery or performance. The purchaser may also consider termination of the contract pursuant to GCC Clause 23.
- 23. Termination for default**
- 23.1. The purchaser, without prejudice to any other remedy for breach of contract, by written notice of default sent to the supplier, may terminate this contract in whole or in part:
- (a) if the supplier fails to deliver any or all of the goods within the period(s) specified in the contract, or within any extension thereof granted by the purchaser pursuant to GCC Clause 21.2;
 - (b) if the Supplier fails to perform any other obligation(s) under the contract; or
 - (c) if the supplier, in the judgment of the purchaser, has engaged in corrupt or fraudulent practices in competing for or in executing the contract.
- 23.2. In the event the purchaser terminates the contract in whole or in part, the purchaser may procure, upon such terms and in such manner as it deems appropriate, goods, works or services similar to those undelivered, and the supplier shall be liable to the purchaser for any excess costs for such similar goods, works or services. However, the supplier shall continue performance of the contract to the extent not terminated.
- 23.3. Where the purchaser terminates the contract in whole or in part, the purchaser may decide to impose a restriction penalty on the supplier by prohibiting such supplier from doing business with the public sector for a period not exceeding 10 years.
- 23.4. If a purchaser intends imposing a restriction on a supplier or any person associated with the supplier, the supplier will be allowed a time period of not more than fourteen (14) days to provide reasons why the envisaged restriction should not be imposed. Should the supplier fail to respond within the stipulated fourteen (14) days the purchaser may regard the intended penalty as not objected against and may impose it on the supplier.
- 23.5. Any restriction imposed on any person by the Accounting Officer / Authority will, at the discretion of the Accounting Officer / Authority, also be applicable to any other enterprise or any partner, manager, director or other person who wholly or partly exercises or exercised or may exercise control over the enterprise of the first-mentioned person, and with which enterprise or person the first-mentioned person, is or was in the opinion of the Accounting Officer / Authority actively associated.
- 23.6. If a restriction is imposed, the purchaser must, within five (5) working days of such imposition, furnish the National Treasury, with the following information:
- (i) the name and address of the supplier and / or person restricted by the purchaser;
 - (ii) the date of commencement of the restriction
 - (iii) the period of restriction; and
 - (iv) the reasons for the restriction.
- These details will be loaded in the National Treasury's central database of suppliers or persons prohibited from doing business with the public sector.
- 23.7. If a court of law convicts a person of an offence as contemplated in sections 12 or 13 of the Prevention and Combating of Corrupt Activities Act, No. 12 of 2004, the court may also rule that such person's name be endorsed on the Register for Tender Defaulters. When a person's name has been endorsed on the Register, the person will be prohibited from doing business with the public sector for a period not less than five years and not more than 10 years. The National Treasury is empowered to determine the period of restriction and each case will be dealt with on its own merits. According to section 32 of the Act the Register must be open to the public. The Register can be perused on the National Treasury website.
- 24. Anti-dumping and countervailing duties and rights**
- 24.1. When, after the date of bid, provisional payments are required, or antidumping or countervailing duties are imposed, or the amount of a provisional payment or anti-dumping or countervailing right is increased in respect of any dumped or subsidized import, the State is not liable for any amount so required or imposed, or for the amount of any such increase. When, after the said date, such a provisional payment is no longer required or any such anti-dumping or countervailing right is abolished, or where the amount of such provisional payment or any such right is reduced, any such favourable difference shall on demand be paid forthwith by the contractor to the State or the State may deduct such amounts from moneys (if any) which may otherwise be due to the contractor in regard to supplies or services which he delivered or rendered, or is to deliver or render in terms of the contract or any other contract or any other amount which may be due to him.
- 25. Force Majeure**
- 25.1. Notwithstanding the provisions of GCC Clauses 22 and 23, the supplier shall not be liable for forfeiture of its performance security, damages, or termination for default if and to the extent that his delay in performance or other failure to perform his obligations under the contract is the result of an event of force majeure.
- 25.2. If a force majeure situation arises, the supplier shall promptly notify the purchaser in writing of such condition and the cause thereof. Unless otherwise directed by the purchaser in writing, the supplier shall continue to perform its obligations under the contract as far as is reasonably practical, and shall seek all reasonable alternative means for performance not prevented by the force majeure event.
- 26. Termination for insolvency**
- 26.1. The purchaser may at any time terminate the contract by giving written notice to the supplier if the supplier becomes bankrupt or otherwise insolvent. In this event, termination will be without compensation to the supplier, provided that such termination will not prejudice or affect any right of action or remedy which has accrued or will accrue thereafter to the purchaser.
- 27. Settlement of Disputes**
- 27.1. If any dispute or difference of any kind whatsoever arises between the purchaser and the supplier in connection with or arising out of the contract, the parties shall make every effort to resolve amicably such dispute or difference by mutual consultation.



- 27.2. If, after thirty (30) days, the parties have failed to resolve their dispute or difference by such mutual consultation, then either the purchaser or the supplier may give notice to the other party of his intention to commence with mediation. No mediation in respect of this matter may be commenced unless such notice is given to the other party.
- 27.3. Should it not be possible to settle a dispute by means of mediation, it may be settled in a South African court of law.
- 27.4. Mediation proceedings shall be conducted in accordance with the rules of procedure specified in the SCC.
- 27.5. Notwithstanding any reference to mediation and/or court proceedings herein,
(a) the parties shall continue to perform their respective obligations under the contract unless they otherwise agree; and
(b) the purchaser shall pay the supplier any monies due the supplier.
- 28. Limitation of liability**
- 28.1. Except in cases of criminal negligence or willful misconduct, and in the case of infringement pursuant to Clause 6;
(a) the supplier shall not be liable to the purchaser, whether in contract, tort, or otherwise, for any indirect or consequential loss or damage, loss of use, loss of production, or loss of profits or interest costs, provided that this exclusion shall not apply to any obligation of the supplier to pay penalties and/or damages to the purchaser; and
(b) the aggregate liability of the supplier to the purchaser, whether under the contract, in tort or otherwise, shall not exceed the total contract price, provided that this limitation shall not apply to the cost of repairing or replacing defective equipment.
- 29. Governing language**
- 29.1. The contract shall be written in English. All correspondence and other documents pertaining to the contract that is exchanged by the parties shall also be written in English.
- 30. Applicable law**
- 30.1. The contract shall be interpreted in accordance with South African laws, unless otherwise specified in SCC.
- 31. Notices**
- 31.1. Every written acceptance of a bid shall be posted to the supplier concerned by registered or certified mail and any other notice to him shall be posted by ordinary mail to the address furnished in his bid or to the address notified later by him in writing and such posting shall be deemed to be proper service of such notice
- 31.2. The time mentioned in the contract documents for performing any act after such aforesaid notice has been given, shall be reckoned from the date of posting of such notice.
- 32. Taxes and duties**
- 32.1. A foreign supplier shall be entirely responsible for all taxes, stamp duties, license fees, and other such levies imposed outside the purchaser's country.
- 32.2. A local supplier shall be entirely responsible for all taxes, duties, license fees, etc., incurred until delivery of the contracted goods to the purchaser.
- 32.3. No contract shall be concluded with any bidder whose tax matters are not in order. Prior to the award of a bid the Department must be in possession of a tax clearance certificate, submitted by the bidder. This certificate must be an original issued by the South African Revenue Services.
- 33. National Industrial Participation (NIP) Programme**
- 33.1. The NIP Programme administered by the Department of Trade and Industry shall be applicable to all contracts that are subject to the NIP obligation.
- 34. Prohibition of Restrictive practices**
- 34.1. In terms of section 4 (1) (b) (iii) of the Competition Act No. 89 of 1998, as amended, an agreement between, or concerted practice by, firms, or a decision by an association of firms, is prohibited if it is between parties in a horizontal relationship and if a bidder (s) is / are or a contractor(s) was / were involved in collusive bidding (or bid rigging).
- 34.2. If a bidder(s) or contractor(s), based on reasonable grounds or evidence obtained by the purchaser, has / have engaged in the restrictive practice referred to above, the purchaser may refer the matter to the Competition Commission for investigation and possible imposition of administrative penalties as contemplated in the Competition Act No. 89 of 1998.
- 34.3. If a bidder(s) or contractor(s), has / have been found guilty by the Competition Commission of the restrictive practice referred to above, the purchaser may, in addition and without prejudice to any other remedy provided for, invalidate the bid(s) for such item(s) offered, and / or terminate the contract in whole or part, and / or restrict the bidder(s) or contractor(s) from conducting business with the public sector for a period not exceeding ten (10) years and / or claim damages from the bidder(s) or contractor(s) concerned.

SPECIAL CONDITIONS OF CONTRACT

1. **AMENDMENT OF CONTRACT**
 - 1.1. Any amendment to or renunciation of the provisions of the contract shall at all times be done in writing and shall be signed by both parties.
2. **CHANGE OF ADDRESS**
 - 2.1. Bidders must advise the Department of Health (institution where the offer was submitted) should their address (domicilium citandi et executandi) details change from the time of bidding to the expiry of the contract.
3. **GENERAL CONDITIONS ATTACHED TO THIS QUOTATION**
 - 3.1. The Department is under no obligation to accept the lowest or any quote.
 - 3.2. The Department reserves the right to communicate in writing with vendors in cases where information is incomplete or where there are obscurities regarding technical aspects of the offer, to obtain confirmation of prices or preference claims in cases where it is evident that a typing, written, transfer or unit error has been made, to investigate the vendor's standing and ability to complete the supply/service satisfactorily.
 - 3.3. **ALL DECISIONS TAKEN BY THE DEPARTMENT ARE FINAL, INCLUDING THE AWARD OR CANCELLATION OF THIS QUOTATION.**
 - 3.4. The price quoted must include VAT (if VAT vendor).
 - 3.5. Should a bidder become a VAT vendor after award or during the implementation of a contract, they may not request the VAT percentage from the Department as the service provider made an offer during the period they were not registered as a VAT vendor. The Department is only liable for any VAT from registered VAT vendors as originally stated on the quotation document.
 - 3.6. The bidder must ensure the correctness & validity of the quotation:
 - (i) that the price(s), rate(s) & preference quoted cover all for the work/item (s) & accept that any mistakes regarding the price (s) & calculations will be at the bidder's risk;
 - (ii) it is the responsibility of the bidder to confirm receipt of their quotation and to keep proof thereof.
 - 3.7. The bidder must accept full responsibility for the proper execution & fulfilment of all obligations conditions devolving on under this agreement, as the Principal (s) liable for the due fulfilment of this contract.
 - 3.8. This quotation will be evaluated based on the preferential procurement points system, specification, correctness of information and/or functionality criteria. All required documentation must be completed in full and submitted.
 - 3.9. Offers must comply strictly with the specification.
 - 3.10. Only offers that meet or are greater than the specification will be considered.
 - 3.11. Late offers will not be considered.
 - 3.12. Expired product/s will not be accepted. All products supplied must be valid for a minimum period of six months.
 - 3.13. Used/ second-hand products will not be accepted.
 - 3.14. A bidder not registered on the Central Suppliers Database or whose verification has failed will not be considered.
 - 3.15. All delivery costs must be included in the quoted price for delivery at the prescribed destination.
 - 3.16. Only firm prices will be accepted. Such prices must remain firm for the contract period. Non-firm prices (including rates of exchange variations) will not be considered.
 - 3.17. In cases where different delivery points influence the pricing, a separate pricing schedule must be submitted for each delivery point.
 - 3.18. In the event of a bidder having multiple quotes, only the cheapest according to specification will be considered.
 - 3.19. Verification will be conducted to identify if bidders have multiple companies and are cover-quoting for this bid.
 - 3.20. In such instances, the Department reserves the right to immediately disqualify such bidders as cover-quoting is an offence that represents both corruption and acquisition fraud.
 - 3.21. Should there be a variation in price and such variation is above the order amount, the Department will reserve the right to place a new order.
4. **NEGOTIATIONS**
 - 4.1. The Department reserves the right to negotiate with the shortlisted bidder/s prior or post award. The terms and conditions for negotiations will be communicated to the shortlisted bidder/s prior to invitation to negotiations. This will be done to ensure value for money and where the bidder/s price is deemed to be exorbitant, uneconomical or not market related.
5. **SPECIAL INSTRUCTIONS AND NOTICES TO BIDDERS REGARDING THE COMPLETION OF THIS QUOTATION.**
 - 5.1. Unless inconsistent with or expressly indicated otherwise by the context, the singular shall include the plural and vice versa and with words importing the masculine gender shall include the feminine and the neuter.
 - 5.2. Under no circumstances whatsoever may the quotation/bid forms be retyped or redrafted. Photocopies of the original bid documentation may be used, but an original signature must appear on such photocopies.
 - 5.3. The bidder is advised to check the number of pages and to satisfy himself that none are missing or duplicated.
 - 5.4. Quotations submitted must be complete in all respects. However, where it is identified that information in a bidder's response, which does not affect the preference points or price, is incomplete in any respect, the said supplier meets all specification requirements and scores the highest points in terms of preference points and price, the Department reserves the right to request the bidder to complete/ submit such information.
 - 5.5. Any alteration made by the bidder must be initialled; failure to do so may render the response invalid.
 - 5.6. Use of correcting fluid is prohibited and may render the response invalid.
 - 5.7. Quotations will be opened in public as soon as practicable after the closing time of quotation.
 - 5.8. Where practical, prices are made public at the time of opening quotations.
 - 5.9. If it is desired to make more than one offer against any individual item, such offers should be given on a photocopy of the page in question. Clear indication thereof must be stated on the schedules attached.
 - 5.10. The Department is under no obligation to pay suppliers in part for work done if the supplier can no longer for fulfil their obligation.
6. **SPECIAL INSTRUCTIONS REGARDING HAND DELIVERED QUOTATIONS**
 - 6.1. Quotation shall be lodged at the address indicated not later than the closing time specified for their receipt, and in accordance with the directives in the quotation documents.



- 6.2. Each quotation shall be addressed in accordance with the directives in the quotation documents and shall be lodged in a separate sealed envelope, with the name and address of the bidder, the quotation number and closing date indicated on the envelope. The envelope shall not contain documents relating to any quotation other than that shown on the envelope. If this provision is not complied with, such quotations/bids may be rejected as being invalid.
- 6.3. All quotations received in sealed envelopes with the relevant quotation numbers on the envelopes are kept unopened in safe custody until the closing time of the quotation/bids. Where, however, a quotation is received open, it shall be sealed. If it is received without a quotation/bid number on the envelope, it shall be opened, the quotation number ascertained, the envelope sealed and the quotation number written on the envelope.
- 6.4. A specific box is provided for the receipt of quotations, and no quotation found in any other box or elsewhere subsequent to the closing date and time of quotation will be considered.
- 6.5. Quotation documents must not be included in packages containing samples. Such quotations may be rejected as being invalid.

7. SAMPLES

- 7.1. In the case of the quote document stipulating that samples are required, the supplier will be informed in due course when samples should be provided to the institution. (This decreases the time of safety and storage risk that may be incurred by the respective institution). The bidders sample will be retained if such bidder wins the contract.
 - (i) If a company/s who has not won the quote requires their samples, they must advise the institution in writing of such.
 - (ii) If samples are not collected within three months of close of quote the institution reserves the right to dispose of them at their discretion.
- 7.2. **Samples must be made available when requested in writing or if stipulated on the document.**
 - If a Bidder fails to provide a sample of their product on offer for scrutiny against the set specification when requested, their offer will be rejected. All (i) testing will be for the account of the bidder.

8. COMPULSORY SITE INSPECTION / BRIEFING SESSION

- 8.1. Bidders who fail to attend the compulsory meeting will be disqualified from the evaluation process.

(i) The institution has determined that a compulsory site meeting Will take place.

(ii) Date: 30 / 01 / 2026 Time: 11 : 00 Place: CHRIST THE KING -ASSEMBLY POINT

Institution Stamp:	Institution Site Inspection / briefing session Official: Full Name: _____ Signature: _____ Date: _____
--------------------	---

9. STATEMENT OF SUPPLIES AND SERVICES

- 9.1. The contractor shall, when requested to do so, furnish particulars of supplies delivered or services executed. If he/she fails to do so, the Department may, without prejudice to any other rights which it may have, institute inquiries at the expense of the contractor to obtain the required particulars.

10. SUBMISSION AND COMPLETION OF SBD 6.1

- 10.1. Should a bidder wish to qualify for preference points they must complete a SBD 6.1 document. Failure by a bidder to provide all relevant information required, will result in such a bidder not being considered for preference point's allocation. The preferences applicable on the closing date will be utilized. Any changes after the closing date will not be considered for that particular quote.

11. TAX COMPLIANCE REQUIREMENTS

- 11.1. In the event that the tax compliance status has failed on CSD, it is the suppliers' responsibility to provide a SARS pin in order for the institution to validate the tax compliance status of the supplier.
- 11.2. In the event that the institution cannot validate the suppliers' tax clearance on SARS as well as the Central Suppliers Database, the quote will not be considered and passed over as non-compliant according to National Treasury Instruction Note 4 (a) 2016/17.

12. TAX INVOICE

- 12.1. A tax invoice shall be in the currency of the Republic of South Africa and shall contain the following particulars:
 - (i) the name, address and registration number of the supplier;
 - (ii) the name and address of the recipient;
 - (iii) an individual serialized number and the date upon which the tax invoice
 - (iv) a description and quantity or volume of the goods or services supplied;
 - (v) the official department order number issued to the supplier;
 - (vi) the value of the supply, the amount of tax charged;
 - (vii) the words tax invoice in a prominent place.

13. PATENT RIGHTS

- 13.1. The supplier shall indemnify the KZN Department of Health (hereafter known as the purchaser) against all third-party claims of infringement of patent, trademark, or industrial design rights arising from use of the goods or any part thereof by the purchaser.

14. PENALTIES

- 14.1. If at any time during the contract period, the service provider is unable to perform in a timely manner, the service provider must notify the institution in writing/email of the cause of and the duration of the delay. Upon receipt of the notification, the institution should evaluate the circumstances and, if deemed necessary, the institution may extend the service provider's time for performance.

- 14.2. In the event of delayed performance that extends beyond the delivery period, the institution is entitled to purchase commodities of a similar quantity and quality as a substitution for the outstanding commodities, without terminating the contract, as well as return commodities delivered at a later stage at the service provider's expense.
- 14.3. Alternatively, the institution may elect to terminate the contract and procure the necessary commodities in order to complete the contract. In the event that the contract is terminated the institution may claim damages from the service provider in the form of a penalty. The service provider's performance should be captured on the service provider database in order to determine whether or not the service provider should be awarded any contracts in the future.
- 14.4. If the supplier fails to deliver any or all of the goods or to perform the services within the period(s) specified in the contract, the purchaser shall, without prejudice to its other remedies under the contract, deduct from the contract price, as a penalty, a sum calculated on the delivered price of the delayed goods or unperformed services using the current prime interest rate calculated for each day of the delay until actual delivery or performance.
- 15. TERMINATION FOR DEFAULT**
- 15.1. The purchaser, without prejudice to any other remedy for breach of contract, by written notice of default sent to the supplier, may terminate this contract in whole or in part:
(i) if the supplier fails to deliver any or all of the goods within the period(s) specified in the contract,
(ii) if the supplier fails to perform any other obligation(s) under the contract; or
(iii) if the supplier, in the judgment of the purchaser, has engaged in corrupt or fraudulent practices in competing for or in executing the contract.
- 15.2. In the event the purchaser terminates the contract in whole or in part, the purchaser may procure, upon such terms and in such manner as it deems appropriate, goods, works or services similar to those undelivered, and the supplier shall be liable to the purchaser for any excess costs for such similar goods, works or services.
- 15.3. Where the purchaser terminates the contract in whole or in part, the purchaser may decide to impose a restriction penalty on the supplier by prohibiting such supplier from doing business with the public sector for a period not exceeding 10 years.
16. **THE DEPARTMENT RESERVES THE RIGHT TO PASS OVER ANY QUOTATION WHICH FAILS TO COMPLY WITH THE ABOVE.**

PREFERENCE POINTS CLAIM FORM IN TERMS OF THE PREFERENTIAL PROCUREMENT REGULATIONS 2022

This preference form must form part of all tenders invited. It contains general information and serves as a claim form for preference points for specific goals.

NB: BEFORE COMPLETING THIS FORM, TENDERERS MUST STUDY THE GENERAL CONDITIONS, DEFINITIONS AND DIRECTIVES APPLICABLE IN RESPECT OF THE TENDER AND PREFERENTIAL PROCUREMENT REGULATIONS, 2022

1. GENERAL CONDITIONS

- 1.1. The following preference point systems are applicable to invitations to tender:
- the 80/20 system for requirements with a Rand value of up to R50 000 000 (all applicable taxes included); and
 - the 90/10 system for requirements with a Rand value above R50 000 000 (all applicable taxes included).

1.2. The applicable preference point system for this tender is the 80/20 preference point system.

- 1.3. Points for this tender (even in the case of a tender for income-generating contracts) shall be awarded for:
- (a) Price; and
 - (b) Specific Goals.

1.4. The maximum points for this tender are allocated as follows:

	POINTS
PRICE	80
SPECIFIC GOALS	20
Total points for Price and Specific Goals	100

1.5. Failure on the part of a tenderer to submit proof or documentation required in terms of this tender to claim points for specific goals with the tender, will be interpreted to mean that preference points for specific goals are not claimed.

1.6. The organ of state reserves the right to require of a tenderer, either before a tender is adjudicated or at any time subsequently, to substantiate any claim in regard to preferences, in any manner required by the organ of state.

2. DEFINITIONS

- (a) "tender" means a written offer in the form determined by an organ of state in response to an invitation to provide goods or services through price quotations, competitive tendering process or any other method envisaged in legislation;
- (b) "price" means an amount of money tendered for goods or services, and includes all applicable taxes less all unconditional discounts;
- (c) "rand value" means the total estimated value of a contract in Rand, calculated at the time of bid invitation, and includes all applicable taxes;
- (d) "tender for income-generating contracts" means a written offer in the form determined by an organ of state in response to an invitation for the origination of income-generating contracts through any method envisaged in legislation that will result in a legal agreement between the organ of state and a third party that produces revenue for the organ of state, and includes, but is not limited to, leasing and disposal of assets and concession contracts, excluding direct sales and disposal of assets through public auctions; and
- (e) "the Act" means the Preferential Procurement Policy Framework Act, 2000 (Act No. 5 of 2000).

3. FORMULAE FOR PROCUREMENT OF GOODS AND SERVICES

3.1. POINTS AWARDED FOR PRICE

3.1.1. THE 80/20 OR 90/10 PREFERENCE POINT SYSTEMS

A maximum of 80 or 90 points is allocated for price on the following basis:

$$\begin{array}{ccc}
 \text{80/20} & & \text{90/10} \\
 \text{Ps} = 80 \left(1 - \frac{\text{Pt} - \text{Pmin}}{\text{Pmin}} \right) & \text{OR} & \text{Ps} = 90 \left(1 - \frac{\text{Pt} - \text{Pmin}}{\text{Pmin}} \right)
 \end{array}$$

Where

- Ps = Points scored for price of tender under consideration
- Pt = Price of tender under consideration
- Pmin = Price of lowest acceptable tender

3.2. FORMULAE FOR DISPOSAL OR LEASING OF STATE ASSETS AND INCOME GENERATING PROCUREMENT

3.2.1. POINTS AWARDED FOR PRICE

A maximum of 80 or 90 points is allocated for price on the following basis:

$$\begin{array}{ccc}
 \text{80/20} & & \text{90/10} \\
 \text{Ps} = 80 \left(1 + \frac{\text{Pt} - \text{Pmax}}{\text{Pmax}} \right) & \text{OR} & \text{Ps} = 90 \left(1 + \frac{\text{Pt} - \text{Pmax}}{\text{Pmax}} \right)
 \end{array}$$

Where

- Ps = Points scored for price of tender under consideration
- Pt = Price of tender under consideration
- Pmax = Price of highest acceptable tender

4. POINTS AWARDED FOR SPECIFIC GOALS

- 4.1. In terms of Regulation 4(2); 5(2); 6(2) and 7(2) of the Preferential Procurement Regulations, preference points must be awarded for specific goals stated in the tender. For the purposes of this tender the tenderer will be allocated points based on the goals stated in table 1 below as may be supported by proof/ documentation stated in the conditions of this tender:
- 4.2. In cases where organs of state intend to use Regulation 3(2) of the Regulations, which states that, if it is unclear whether the 80/20 or 90/10 preference point system applies, an organ of state must, in the tender documents, stipulate in the case of--
- (a) an invitation for tender for income-generating contracts, that either the 80/20 or 90/10 preference point system will apply and that the highest acceptable tender will be used to determine the applicable preference point system; or
 - (b) any other invitation for tender, that either the 80/20 or 90/10 preference point system will apply and that the lowest acceptable tender will be used to determine the applicable preference point system,
- then the organ of state must indicate the points allocated for specific goals for both the 90/10 and 80/20 preference point system.

**Table 1: Specific goals for the tender and points claimed are indicated per the table below.
Note to tenderers: The tenderer must indicate how they claim points for each preference point system.**

The specific goal/s allocated points in terms of this tender	Number of points allocated (80/20 system)	Number of points claimed (80/20 system)
RDP Goal: Full points allocated to promote South African owned enterprises	20	

DECLARATION WITH REGARD TO COMPANY/FIRM

- 4.3. Name of company/firm: _____
- 4.4. Company registration number: _____
- 4.5. TYPE OF COMPANY/ FIRM [tick applicable box]
- Partnership/Joint Venture / Consortium
 - One-person business/sole propriety
 - Close corporation
 - Public Company
 - Personal Liability Company
 - (Pty) Limited
 - Non-Profit Company
 - State Owned Company

- 4.6. I, the undersigned, who is duly authorised to do so on behalf of the company/firm, certify that the points claimed, based on the specific goals as advised in the tender, qualifies the company/ firm for the preference(s) shown and I acknowledge that:
- i) The information furnished is true and correct;
 - ii) The preference points claimed are in accordance with the General Conditions as indicated in paragraph 1 of this form;
 - iii) In the event of a contract being awarded as a result of points claimed as shown in paragraphs 1.4 and 4.2, the contractor may be required to furnish documentary proof to the satisfaction of the organ of state that the claims are correct;
 - iv) If the specific goals have been claimed or obtained on a fraudulent basis or any of the conditions of contract have not been fulfilled, the organ of state may, in addition to any other remedy it may have –
 - (a) disqualify the person from the tendering process;
 - (b) recover costs, losses or damages it has incurred or suffered as a result of that person's conduct;
 - (c) cancel the contract and claim any damages which it has suffered as a result of having to make less favourable arrangements due to such cancellation;
 - (d) recommend that the tenderer or contractor, its shareholders and directors, or only the shareholders and directors who acted on a fraudulent basis, be restricted from obtaining business from any organ of state for a period not exceeding 10 years, after the audi alteram partem (hear the other side) rule has been applied; and
 - (e) forward the matter for criminal prosecution, if deemed necessary.

<p>_____</p> <p>SIGNATURE(S) OF TENDERER(S)</p> <p>SURNAME AND NAME: _____</p> <p>DATE: _____</p> <p>ADDRESS: _____</p> <p>_____</p> <p>_____</p>

PROVINCE OF KWAZULU-NATAL
DEPARTMENT OF HEALTH

ZNQ –

**CHRIST THE KING HOSPITAL – REPAIRS TO ALUMINIUM DOORS (LECTURE HALL
MAIN KITCHEN AND VERANDA COVER AT PHYSIO DEPARTMENT) AT CHRIST THE
KING HOSPITAL**

1.1 SCOPE OF CONTRACT

This Contract is for the execution of the project indicated above.

1.2 CONTRACT DRAWINGS

No Drawing attached

1.3 CONDITIONS OF CONTRACT AND PRELIMINARIES

1.3.1 PERIOD OF CONTRACT

Six (06) *Weeks* as the Contract Period for the completion of the Work from date of Site handover.

1.3.2 CONTRACT GUARANTEE:

The Successful Bidder will **NOT** be required to submit a contract guarantee.

1.3.3 GUARANTEE PERIOD

The guarantee period for the completion of the Structural work and all materials must be a minimum of Three (3) Calendar Months from the date of first delivery.

1.3.4 SITE AND MODE OF PROCEDURE

The work contained in this contract will be carried out on the site of the existing at **Christ the King Hospital**.

The Bidder is advised that the existing premises will be occupied throughout the period of the contract, and that the minimum amount of disruption to services is of the utmost importance.

Damage to the existing buildings - Bidders to note that any damages done or occurring to any of the buildings will be repaired at the expense of the contractor/ Bidder.

The repairs must be to the satisfaction of the Kwazulu - Natal Department of Health. Bidders are advised to visit the site prior to tendering and to acquaint themselves with the nature of the work to be done and access to the siting of the existing buildings etc., as no claim whatsoever will be allowed on the grounds of ignorance of the conditions under which the work will be executed.

NB: Bidders are advised to examine the drawings and visit the site prior to quoting and to acquaint themselves with the nature of the work to be done

and access to the siting of the existing buildings etc., as no claim will be allowed on the grounds of ignorance of the conditions under which the work will be executed.

1.3.5 SATISFACTORY INSTALLATION

The whole of the installation shall be carried out in accordance with the South African Bureau of Standards Code of Practice for the application of National Building Regulations, the KZNPA Standard Preambles to all Trades, the KZNPA General Electrical Specification, ICASA, Telecommunications regulations, the South African Bureau of Standards Code of Practice for the Wiring of Premises SABS 0142 and the Occupational Health and Safety Act and Regulations 85/1993 as amended.

Copies of the KZNPA Standard Preambles to all Trades and the KZNPA General Electrical Specification are available at the office of the Secretary for Health – KwaZulu-Natal and can be obtained on request.

PROVINCE OF KWAZULU-NATAL
DEPARTMENT OF HEALTH

ZNQ –

CHRIST THE KING HOSPITAL – REPAIRS TO ALUMINIUM DOORS (LECTURE HALL
MAIN KITCHEN AND VERANDA COVER AT PHYSIO DEPARTMENT) AT CHRIST THE
KING HOSPITAL

TECHNICAL SPECIFICATIONS

2. TECHNICAL SPECIFICATION

2.1 GENERAL

This TECHNICAL SPECIFICATION shall be read in conjunction with all other sections of the SPECIFICATION and cognisance shall be taken of the clauses relevant to this particular installation, whether any specific clauses are referred to or not.

2.2 *Standard Preambles*

This is available from the department on request.

2.3 *Health and Safety Specification*

Health and Safety Plan with Risk assessment schedule is to be compiled taking cognisance of the specific type of patient's that walk around the institution all day. All areas are to be protected at all times from patients falling in. All new and old materials are to be securely stored during construction to eliminate any person from rolling them around or playing inside them.

Grading: 1 GB and above

CIDB COMPLIANCE

- 2.4 Amendments: Functionality in different contracting strategies in line with regulations 4.3.3 of the CIDB regulations, where functionality is evaluated, at least three Persons who are fully conversant with the Technical aspects of the scope of works shall undertake such evaluation.

**PROVINCE OF KWAZULU-NATAL
DEPARTMENT OF HEALTH**

ZNQ –

**CHRIST THE KING HOSPITAL – REPAIRS TO ALUMINIUM DOORS (LECTURE HALL
MAIN KITCHEN AND VERANDA COVER AT PHYSIO DEPARTMENT) AT CHRIST THE
KING HOSPITAL**

3. SCOPE OF WORK

The work to be carried out under this contract includes the supply of all materials, and including all labour to carry out all electrical work and leaving in service condition to the satisfaction of the Secretary for Health: KwaZulu-Natal.

3.1. The work comprises of

3.2 Supply and install the following

- a) alterations (Removal of aluminum doors, handles, locks etc.
- b) new cylinder lock etc.
- c) cabin hook.
- d) Door stopper.
- e) Supply and install aluminum windows

Note all work will be re measured on completion.

ALTERATIONS SITE VISIT:

Tenderers are advised to visit the site prior to tendering and satisfy themselves as to the nature and extent of the work to be done, also to examine the condition of all existing buildings as no claim will be entertained on the grounds of ignorance of the conditions under which the work was to be executed. **MATERIALS FROM THE ALTERATIONS:** — unless otherwise stated, will become the property of the Contractor and all these materials, together with all rubbish and debris must be carried away and the site left clean and unencumbered. Items described as “removed” shall mean removed from the site. Credit for the value of materials from the alterations is to be allowed for on the Summary/ Final Summary page. Items described as to be re-used or to be handed over to the Administration are to be dismantled where necessary and stacked on site where directed, and the Contractor will be responsible for their removal and storage until required, and shall make good all items missing, damaged or broken at his own expense. Unless otherwise described, no materials from the alterations shall be re-used in any new work without the written approval of the Department. Prior to the removal of any timbers from the site, these are to be inspected by Government Entomologists. If any of these timbers are infested by wood destroying agencies, these timbers are to be disposed of in the manner prescribed by the Government Entomologist. In taking down and removing existing work, particular care must be taken to avoid any structural or other damage to the remaining portions of the buildings.

PARTITIONS: These are to be of an approved system of standard construction, with an average sound rating of not less than 30 decibels taken over the whole face area. Framing is to be natural finish anodised aluminium comprising posts at 1200mm centres unless otherwise described, with transom rails where specified, fitted between the posts, a STANDARD PREAMBLES TO ALL TRADES 40 Rev 3 January 2009 rail against ceiling and an aluminium standard skirting on each side at base, all neatly and securely fixed together. Provision is to be made at the base of the partitions and in the ceiling rails and posts for electrical wiring, which will be installed under the electrical sub-contract, and the ceiling tails and end posts are to be fitted with continuous removable access plates. Solid panelling is to be approved solid chip core panels of the thickness specified faced on both sides as described in the items. Glazed panels are to be glazed as required, complete with all necessary natural finish anodised aluminium glazing beads and vinyl glazing strips. Louver panels where specified are to be approved natural finish anodised aluminium adjustable louver sets each comprising head and sill weather bars and two jamb strips each fitted with louver brackets with spring loaded clips for and fitted with and including louvers as required and complete with tilt bars and operating lever handles. Where the openings are not the correct size to suit a full number of standard width louver blades, an alternate head weather bar must be provided to suit a fixed louver blade of the required width. The louver sets are to be fitted with the jamb strips positioned horizontally so that the louvers will be fixed vertically. Partitions are to be in 1200mm modules, unless otherwise specified, except at ends where the odd lengths are to be made up by a narrow width at one end of the partition. Ends of partitions against walls, window frames, etc. and the top edge of partitions against ceilings are to be fitted on both sides of partition with approved vinyl scribing sections fitted between the structure and the end post or top rail of the partition. Plain openings are to have aluminium frames similar to door openings neatly fitted into the framing. Doors are to be solid laminated flush doors complying with SANS Specification 545. The doors are to be finished on both sides with veneer as described in the items and concealed on both stiles with matching hardwood edge strips. Where doors are described as having observation openings, these openings are to be of the sizes stated, glazed as specified with all edges bedded in approved neoprene gaskets and fixed with 10 x 25mm wrot matching hardwood rebated glazing beads mitred round and bradded to both sides. Rates for doors are to include for all necessary additional aluminium framing to form door openings, and for hanging the doors on and including one and a half pairs of 102mm satin chrome finish brass hinges to each door. All locks to doors in demountable partitions are to be supplied with two keys, and are to be controlled by the same master key as the mortise locks used elsewhere in the Contract when specified. Unless otherwise specified all veneered solid panelling and doors are to be finished as follows: — Prepare, stop with tinted stopping, apply an approved stain as necessary to achieve uniform colour appearance, and three coats of approved clear matt polyurethane finish including burnishing with steel wool between coats. Rates for demountable partitions are to include for supplying, assembling, erecting, finishing, glazing and fixing complete between finished surfaces of concrete floors, plastered walls and ceilings, and all in accordance with the manufacturer's ins

IRONMONGERY

Ironmongery is to be to the approval of the Department and rates are to include for fixing screws of corresponding metal and finish and for oiling and easing as required at completion. Where catalogue references are given, the articles are to be of the brand specified or other approved. No two-lever mortise locks are to be used. Mortise locks, cylinder locks, cupboard locks, etc. are to differ so that no key will pass a second lock, unless otherwise specified. Where mortise locks, cylinders, locks, etc. are specified to be "en-suite" they are to be made "en-suite" in the specified number of "suites". The "suites" are to be controlled by differing

sub-master keys with a grand master key controlling all "suites", and no sub-master is to pass any lock of another "suite". All locks are to be fitted with two keys and the locks are to be stamped with consecutive numbers and the keys to each are to be stamped to correspond with the lock. Items of ironmongery specified as chrome plated or satin chrome finish are, unless otherwise specified, to be chromium plated or satin chrome finish on solid brass. Items of ironmongery specified aluminium are to be natural anodised. Where items of ironmongery are specified as fixed to pressed steel door frames, the Contractor is to ensure that the suppliers of the steel frames prepare the frames for all keeps and do all mortising and drilling required and receive all information necessary

**PROVINCE OF KWAZULU-NATAL
DEPARTMENT OF HEALTH**

ZNQ –

**CHRIST THE KING HOSPITAL – REPAIRS TO ALUMINIUM DOORS (LECTURE HALL
MAIN KITCHEN AND VERANDA COVER AT PHYSIO DEPARTMENT) AT CHRIST THE
KING HOSPITAL**

SCHEDULE OF RATES

4.1 ITEMS AND PRICING

The Department reserves the right to place an order for any quantities of items included in the Schedules. The Schedule of Rates must also not be assumed to include and describe every detail of the supply requirement, but must be taken and read in conjunction with the other parts of the document. Thus the supplier shall not have claim for further payment in respect of any order which may be described or implied in the contract, although apparently no corresponding items are given in the Schedule of Rates. The supplier shall be deemed to have satisfied himself before quoting as to the correctness and sufficiency of his quote for the contract and of the rates and prices stated in the Schedule of Rates.

4.2 TAX AND DUTIES

Prices, quoted and paid, must include all customs, excise and import duties, and any other tariffs or taxes levied by the government or statutory body having jurisdiction on the goods provided under this contract, **including Value Added Tax (applicable to the current rate).**

3.3 RATES

Except where provision is made in the Schedule of Rates, the rates and prices inserted shall be the full rates and prices for the service delivered described under the respective items and shall cover all labour, transport, overhead charges and profit, etc. as well as the general liabilities, obligations and risks arising out of the Conditions of Contract, the overhead charges and profit being spread proportionately over the rates of the relative items in the Schedule of Rates.

Item no.	Description	Qty	Rate	Amount
	<p style="text-align: center;"><u>BILL NO 1</u></p> <p>ALTERATIONS</p> <p>The Tenderer is referred to the relevant Clauses in the Model Preambles to All Trades and to the Supplementary Preambles which are incorporated at the back of these Bills of Quantities.</p> <p>Unless otherwise described the preambles and full Descriptions of all items appearing in all the bills of the preceding sections are to apply equally to this section.</p> <p>NOTES</p> <p>The materials to be used and the work to be done are to be similar and equal to the new work Contained in all the subsequent Bills.</p> <p>Unless otherwise described, the preambles and full Descriptions of the items appearing in all the subsequent Bills are to apply equally to this Bill.</p> <p>Items described as to be re-used or to be handed over to the Director are to be carefully dismantled where necessary and stacked on site</p> <p>where directed, and the Contractor will be responsible for their removal and storage until required, and shall make good all items missing, damaged or broken at his own expense.</p> <p>Unless otherwise described, no materials from the alterations shall be re-used in any new work without the written approval of the Director,</p> <p>with the exception of facing bricks required in filling to openings, etc., which may be re-used if free of cracks and chips and properly cleaned of all mortar.</p>			

Item No.	Description	Qty	Rate	Amount
	<p>The Contractor is to take all dimensions affecting the existing buildings on the site as he will be solely responsible for all new work being to the correct sizes.</p> <p>Prices are to include for carting away from site all materials not specifically mentioned as being stored on site for re-use or handed over to the Director and all rubbish, debris, etc., arising from the alterations, etc., and for making good all work damaged or disturbed to the approval of the Director.</p> <p>Tenderers are to include in pricing for the statutory Requirements with regard to the demolition and disposal of asbestos cement material arising from the works.</p> <p>MATERIALS FROM THE ALTERATIONS:</p> <p>Unless otherwise stated, will become the property of the Contractor and all these materials, together with all rubbish and debris must be carried away and the site left clean and unencumbered.</p>			

Item no.	Description	Unit	Qty.	Rate	Amount
REMOVAL OF EXISTING:					
<u>LECTURE HALL</u>					
<u>Front door</u>					
1.	cylinder lock on the aluminum door, handles, cabin hook etc. and make good.	no	01.		
<u>Back sliding door 1</u>					
2.	aluminum sliding door, handles etc. and make good.	no.	01.		
3.	Glass and need to be reduced in order to fit on modified aluminium door size of the aluminium door is 2030mm height x 850mm wide	no.	01.		
<u>Back sliding door 2</u>					
4.	aluminum sliding door, handles etc. and make good.	no.	01.		
5.	glass and need to be reduced in order to fit on modified aluminium door size of the aluminium door is 2030mm height x 850mm wide	no.	01.		
<u>MAIN KITCHEN</u>					
6.	Aluminium double doors (along the passage)	no.	01.		
7.	Locking mechanism, cylinder lock complete and make good	no.	02.		
8.	Handles and make good., flat barrel bolts, etc. and make good.	no.	02.		
9.	Aluminium double doors (facing outside)	no.	01.		
10.	Locking mechanism, cylinder lock complete and make good	no.	02.		
11.	Handles and make good., flat barrel bolts, etc. and make good.	no.	02.		
Carried to Collection Summary Alterations					R

Item no.	Description	Unit	Qty.	Rate	Amount
1.	<p style="text-align: center;">REMOVAL OF EXISTING:</p> <p><u>Veranda: Physio department</u></p> <p>Take old wooden window frame 118cm x 166 cm and make good for installation of the new aluminum windows all the area as per figure 1 and 2. Ensure that measurements are taken before the windows are made so that any disturbance can be reported to the chief artisan and be ratified before new installation</p> <p>Carried to Collection Summary Alterations</p>	ITEM	01.		R

Item no.	Description	Unit	Qty.	Rate	Amount
	BILL NO. 2				
	IRONMONGERY:				
	SUPPLEMENTARY PREAMBLES				
	Finishes to ironmongery				
	Where applicable finishes to ironmongery are indicated by suffixes in accordance with the following list: BS Satin bronze lacquered CH Chromium plated SC Satin chromium plated				
	HINGES, FLOOR SPRING HINGES, BOLTS, PANIC BOLTS, ETC.				
	Supply, deliver and install:				
	<u>LECTURE HALL</u>				
	<u>Front door</u>				
	<u>Aluminium Door handles + cylinder lock and insert lock. Suitable for aluminium door</u>				
1.	Lock	no.	01		
	<u>cabin hook, chrome plated, 150mm</u>				
	<u>width: 34mm</u>				
	<u>height: 23mm</u>				
2.	cabin hook	no.	01.		
	<u>Back sliding door 1</u>				
	<u>Aluminium Door handles + cylinder lock and insert lock. Suitable for aluminium door</u>				
3.	Lock	no.	01.		
	<u>aluminium sinkless hinge</u>				
	<u>Length : 200mm</u>				
	<u>Width : 44mm</u>				
4.	aluminium sinkless hinge	no.	02.		
	<u>door stopper, half moon satin nickel length 44mm height 21mm</u>				
5.	door stopper	no.	01.		
	Carried to Collection Summary				
	Ironmongery				R

Item no.	Description	Unit	Qty.	Rate	Amount
	Back sliding door 2				
	<u>Aluminium Door handles + cylinder lock and insert lock.</u> <u>Suitable for aluminium door</u>				
1.	Lock	no.	01		
	<u>aluminium sinkless hinge</u> <u>Length : 200mm</u> <u>Width : 44mm</u>				
2.	aluminium sinkless hinge	no.	02.		
	<u>door stopper, half moon satin nickel length 44mm height</u> <u>21mm</u>				
3.	door stopper	no.	01.		
	<u>MAIN KITCHEN</u>				
	Aluminium double doors (along the passage)				
	<u>Aluminium Door handles + cylinder lock and insert lock.</u> <u>Suitable for aluminium door</u>				
4.	lock	no.	01		
	<u>aluminum door handles on plate - 150 x 150mm - pull</u> <u>handle</u>				
5.	pull handle	no.	02.		
	<u>flush bolt for aluminium doors 150mm in size</u>				
6.	flush barrel bolt	no.	02.		
	Carried to Collection Summary Ironmongery				R

Item no.	Description	Unit	Qty.	Rate	Amount
	<u>MAIN KITCHEN</u>				
	Aluminium double doors (facing outside)				
	<u>Aluminium Door handles + cylinder lock and insert lock. Suitable for aluminium door</u>				
1.	lock	no.	01		
	<u>aluminum door handles on plate - 150 x 150mm - pull handle</u>				
2.	pull handle	no.	02.		
	<u>flush bolt for aluminium doors 150mm in size</u>				
3.	flush barrel bolt	no.	02.		
	Carried to Collection Summary				
	Ironmongery				
					R

Item No.	Description	Page	Amount
	<u>BILL NO. 2</u>		
	Ironmongery		
	<u>Collection summary</u>		
		13.	
		14.	
		15.	
	Carried to Final Summary Ironmongery		R

Item No.	Description	Unit	Qty.	Rate	Amount
	<p style="text-align: center;"><u>BILL NO. 3</u></p> <p>METAL WORK</p> <p>CPAP WORK GROUP NO. 136 UNLESS OTHERWISE STATED)</p> <p>The Tenderer is referred to the relevant clauses in the Specification of Materials and Methods to be used PW371, the Supplementary Preambles and Notes.</p> <p>ALUMINIUM WINDOWS, DOORS, SCREENS, ETC.</p> <p><i><u>'Sheerline System 30' natural anodised aluminium windows glazed as scheduled and factory fitted with burglar bars to all opening sections:</u></i></p> <p>After fabrication the doors, glazing beads, etc., are to be properly etched and anodised bronze with an anodised film thickness of 25 microns in accordance with SABS 999.</p> <p>The frames are to be formed perfectly flat on all faces, truly square and properly jointed at angles and intersections.</p> <p>Prices for the frame and doors are to include for assembling the component parts, setting up in position and plugging and screwing fixing lugs to concrete, oiling and easing all opening sections, protecting from damage and cleaning down and leaving in perfect condition at completion</p> <p>The structure must be done by accredited supplier</p> <p>Metal work</p>				

Item No.	Description	Unit	Qty.	Rate	Amount
1.	<p>Supply, deliver and install:</p> <p style="text-align: center;"><u>LECTURE HALL</u></p> <p>Back sliding door 1</p> <p>recondition the aluminium door by reducing the size from 2065 height x 920mm wide to 2 030mm height x 850mm wide. Introduce new long stile with height of 2030mm.</p>	Item.	01.		
2.	<p>Back sliding door 2</p> <p>recondition the aluminium door by reducing the size from 2065 height x 920mm wide to 2 030mm height x 850mm wide. Introduce new long stile with height of 2030mm.</p>	Item	01.		
3.	<p style="text-align: center;"><u>MAIN KITCHEN</u></p> <p>Aluminium double doors (along the passage)</p> <p><u>silver aluminium strip to be installed on the bottom the double doors, in order to reduce the gap on the bottom of the doors (double doors). Size length 900mm x 50mm wide x 1mm thick</u></p> <p>aluminium strip</p>	no.	04.		
4.	<p>Aluminium double doors (facing outside)</p> <p><u>silver aluminium strip to be installed on the bottom the double doors, in order to reduce the gap on the bottom of the doors (double doors). Size length 900mm x 50mm wide x 1mm thick</u></p> <p>aluminium strip</p>	no.	04.		
	<p>Carried to Collection Summary</p>				R

Item No.	Description	Unit	Qty.	Rate	Amount
	<p>Supply, deliver and install:</p> <p style="text-align: center;"><u>Veranda: Physio department</u></p> <p>ALUMINIUM WINDOW FRAME DETAILS</p> <p><u>The frame is suitable for aluminium windows.</u> <u>Size of the frame 50mm wide, thickness 3mm.</u></p> <p>METHOD OF INSTALLING THE FRAME, has to be installed using hilti nails, length 55mm with diameter of 6mm</p>				
1.	aluminium Frame Front: (Drawing 1) Opening size 308cm wide x 166cm high	Item.	01.		
2.	aluminium Frame Side: (Drawing 2)	Item	01.		
	<p>ALUMINIUM WINDOWS DETAILS</p> <p><u>aluminium window with equal window panes, both windows are sliding. Consist of window sliders, rollers, locks and handles. Insulation seals against draughts, water and dust must be included.</u></p> <p><u>DRAWING 1</u></p>				
3.	aluminium window Front	no.	01.		
	<p><u>aluminium window without the opening. Insulation seals against draughts, water and dust must be included. <u>DRAWING 2</u></u></p>				
4.	aluminium window Side	no.	01.		
	Carried to Collection Summary				

Item no.	Description	Unit	Qty.	Rate	Amount
	<u>BILL NO.6</u>				
	GLAZING				
	The Tenderer is referred to the relevant clauses in the Specification of Materials and Methods to be used PW371, the Supplementary Preambles and Notes.				
	The glazing and fixing of glass in buildings shall be in accordance with SANS. Code of practice 0317. All laminated safety Glass is to have the manufacturer's name or motif sand-blasted in one corner of each pane.				
	Supply, deliver and install clear glass with the thickness of 4mm				
	<u>Veranda: Physio therapy department</u>				
	<u>WINDOW 1 Front (Figure 1).</u>				
1.	Total window panes not exceeding 5.5m ²	Item	01		
	<u>WINDOW 1 (FACING THE ROAD).</u>				
2.	Total window panes not exceeding 4m ²	Item	01		
	Carried to final Summary				
	Glazing				
					R

Item No	Description	Page No	Amount
<u>Final summary</u>			
1.	Alterations.	12.	
2.	Ironmongery.	16.	
3.	Metal work.	20.	
4.	Glazing	21.	
5.	OHS requirements including safety file	Quoted amount	
Carried to quotation form			R

Figure 1

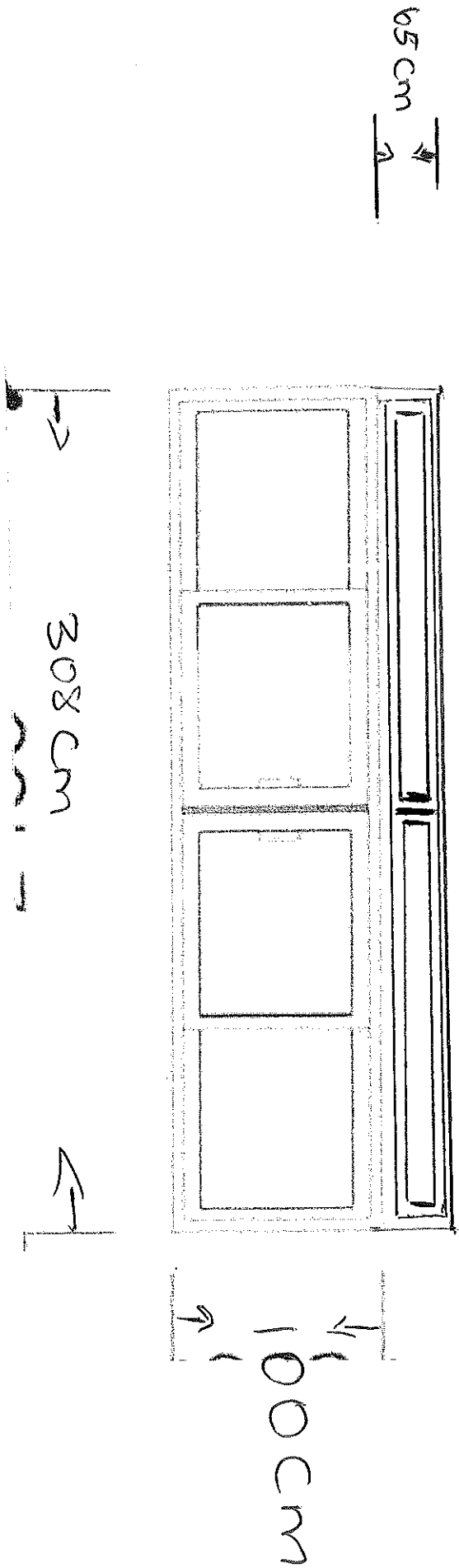

Sliding Window Front View

Figure 2

Side window

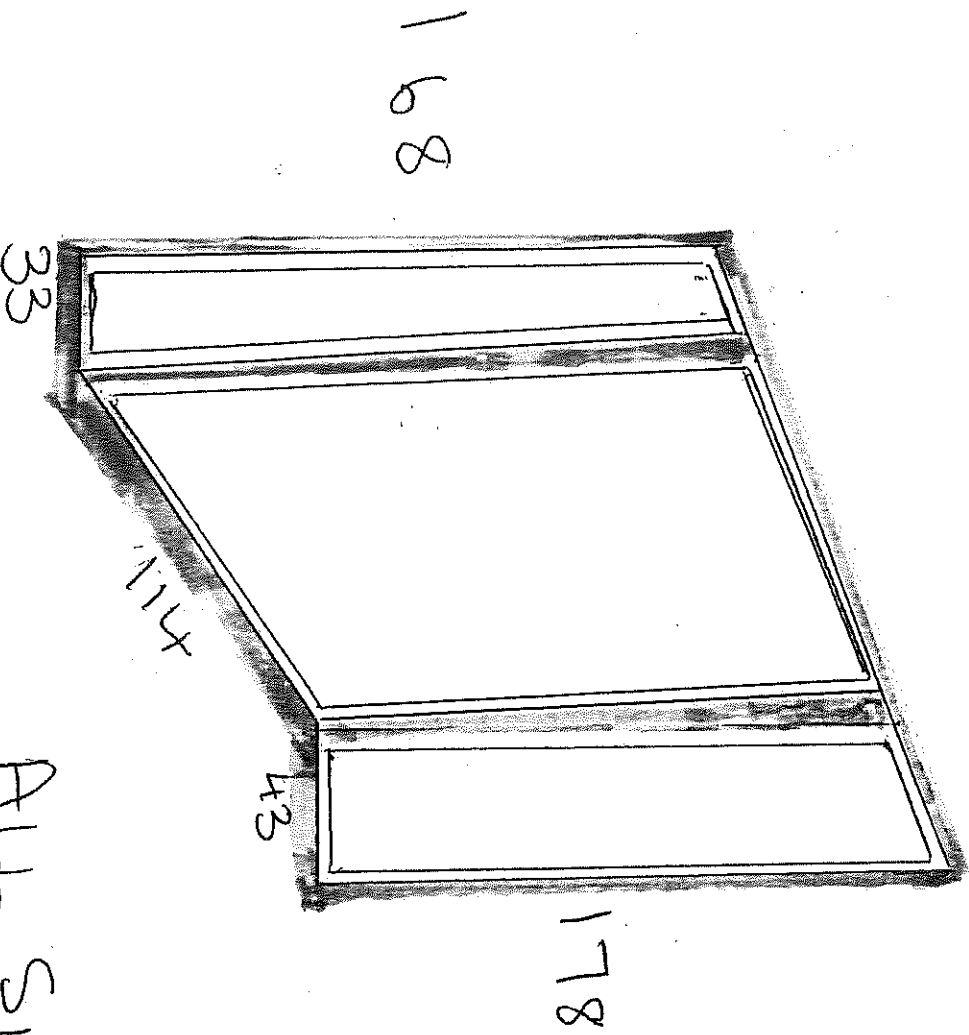

ALL SIZES in Cm



Quotation No.	ZNQ: CTK138/25/26
Quotation Description	Repairs to aluminum doors at main kitchen an lecture hall and veranda cover at physio department

EVALUATION CRITERIA

This institution intends to evaluate valid quotations using **five (4) evaluation stages**. These are peremptory requirements, should the bidder/tenderer fail to comply with any of the stages as stated below, the quotation will be regarded as non-responsive, and will not progress to the final stage of evaluation:

Stage 1: Administrative Compliance, Compulsory and Mandatory Requirements

Stage 2: Capacity to Deliver

Stage 3: Compliance with Specification

Stage 4: Price and Preference Points System (Specific Goals)

Bidder Initial here: _____

EVALUATION CRITERIA



STAGE 1: ADMINISTRATIVE, COMPULSORY COMPLIANCE AND MANDATORY REQUIREMENTS

NO.	REQUIREMENTS	INCLUDED IN THE PUBLISHED DOCUMENT?	TO BE RETURNED BY BIDDER/ TENDERER?
Administrative Compliance			
1.	PARTICULARS OF QUOTATION	YES	YES
2.	OFFICIAL PRICE PAGE FOR QUOTATIONS OVER R2 000.01	YES	YES
3.	BIDDER'S DISCLOSURE (SBD4)	YES	YES
4.	GENERAL CONDITIONS OF CONTRACT (GCC)	YES	YES
5.	SPECIAL CONDITIONS OF CONTRACT (SCC)	YES	YES
6.	PREFERENCE POINTS CLAIM FORM IN TERMS OF THE PREFERENTIAL PROCUREMENT REGULATIONS 2022 (SBD 6.1)	YES	YES
7.	TO DISREGARD BIDS OR QUOTATION FOR SUPPLIERS OR CONTRACTORS WHO FAILED TO PERFORM ON ANY PREVIOUS CONTRACT FOR THE SAME ITEM ADVERTISED	NO	INSTITUTION TO VERIFY
Compulsory Compliance			
8.	FULL COMPLETION OF ATTACHED SCHEDULE OF RATES	YES	YES
9.	SUPPLIER UPDATED CIPC REGISTRATION DOCUMENTS	NO	YES
10.	RECENT CENTRAL SUPPLIER DATABASE COMPLIANCE REPORT (CSD)	NO	YES
Mandatory Requirements			
11.	THE BIDDER MUST PROVIDE PROOF THAT THE ITEMS TO BE SUPPLIED ARE SABS OR SANS APPROVED	NO	NO
12.	VALID CIDB 1GB OR MORE CURRENT REGISTRATION DOCUMENTS	NO	YES

Note: This relates to administrative, compulsory and mandatory returnable documents which must be fully completed, and submitted, should you fail to submit any of the above returnable documents, your offer will be treated as non-responsive and will not proceed to the next stage of evaluation. The department reserve a right to verify validity of the documents submitted, should it be discovered that the information submitted is misrepresented or falsified the quotation will be disqualified or contract maybe be terminated.

Stage 2: Capacity to deliver:

Bidder Initial here: _____



EVALUATION CRITERIA

The non-compliant returnable documents will be treated as no-responsive; the tender will be disqualified, and will not proceed to the next stage of evaluation

	Evaluation criteria	Deliverables	Official scoring
Competency and Experience	Bidder must submit a schedule of project completed which shall include period over which the project was completed and value of project	Submission of two appointment letters or official orders and two completion certificate for installation / repairs of aluminium windows / doors.	

STAGE 3: COMPLIANCE WITH SPECIFICATION

Requirement	Complies with Specification Yes /No
The bidder / Tenderer to confirm that the product supplied complies with attached specification document, should you fail to indicate compliance your quotation will not progress to the next stage of evaluation.	

STAGE 4: PRICE AND PREFERENCE POINTS

The value of this quotation is estimated not to exceed R 50 000 000 (inclusive of all applicable taxes), therefore the 80/20 preference point system shall be applicable. Points for this quotation will be awarded for:

CATEGORY	POINTS
PRICE	80
SPECIFIC GOALS	20
Total points for Price and must not exceed	100

The Department has identified the following specific goal:

Specific Goal	Number of Points allocated	Proof To Claim Specific Goal (Returnable Documents)
South African owned enterprises	20	1. CIPC Certificate
NOTE: Should a responsive bidder fail to submit proof to claim points, as stated above this will not result in disqualification; however, the bidder will not be awarded points for specific goals.		

Name of End-User	ESG Zikalala	Name of SCM representative	S. Mfelo
Designation /Rank (in full)	Chief Artisan	Designation /Rank (in full)	SpM Clerk
Signature		Signature	
Date	29/09/2025	Date	29/09/2025

Bidder Initial here: _____



ANNEXURE A: SPECIFICATION FORM

NAME OF PROCURING FACILITY		CHRIST THE KING HOSPITAL	
ITEM DESCRIPTION		Repairs to aluminum doors at main kitchen an lecture hall and veranda cover at physio department	
ITEM PURPOSE		Repairs and upgrading	
ITEM DETAILED SPECIFICATION (INCLUDE SIZE, COLOUR, MATERIAL, ETC.)			COMPLIES (YES/NO)
1.	SABS approved		
2.	Industrial material		
3.	Heavy duty		
4.	Use safety 4mm glass		
QUALITY STANDARD		SABS APPROVED	
UNIT OF MEASURE OR PACKAGING I.E. (UNIT/BOX/ROLL/PACK/BAIL ETC)		As per attached schedule of rates	
SAMPLE REQUIRED (YES/NO) IF YES WHEN AND HOW?			
ADDENDUM TO SPECIFICATION ATTACHED (YES OR NO)		YES, specification attached.	

Note:

1. Health Technology Services (HTS) may have additional Terms of Reference or Scope of Work
2. Facility Maintenance may have additional Terms of Reference or Scope of Work
3. Other professional Services may have additional Terms of Reference or Scope of Work

SPECIFICATION APPROVED BY

Name of End-user (in full)	ESG Zikalala	Name of SCM Rep (in full)	N. S. Shendw
Designation / Rank (in full)	Chief Artisan	Designation/ Rank (in full)	SCC
Signature		Signature	
Date	29/09/2025	Date	29/09/2025

Bidder Initial here: _____