



KWAZULU-NATAL PROVINCE

HEALTH
REPUBLIC OF SOUTH AFRICA

Quotation Advert

Opening Date: 14/01/2026
Closing Date: 21/01/2026
Closing Time: 11:00

INSTITUTION DETAILS

Institution Name: Hlabisa Hospital
Province: KwaZulu-Natal
Department of entity: Department of Health
Division or section: Central Supply Chain Management
Place where goods/
service is required: **HLABISA HOSPITAL**
Date Submitted: 13/01/2026

ITEM CATEGORY AND DETAILS

Quotation number: ZNQ: HLB: 153 25/26
Item Category: Goods
Item Description: **SUPPLY AND INSTALL INDUSTRIAL WASHING
MACHINE AND TUMBLE DRYER**
Quantity (if supplies): 02

COMPULSORY BRIEFING SESSION / SITE VISIT

Select Type: Complusory Briefing
Date: N/A
Time: N/A
Venue: N/A

QUOTES CAN BE COLLECTED FROM: N/A

QUOTES SHOULD BE DELIVERED TO: 60 SAUNDERS STREET, HLABISA HOSPITAL
MAINGATE TENDERBOX, HLABISA, 3937

ENQUIRIES REGARDING ADVERT MAY BE DIRECTED TO:

Name: N.L DLAMINI
Email: hlabisa.quotations@kznhealth.gov.za
Contact number: 035 838 8676
Finance Manager Name: MR I.T NDWANDWE
Finance Manager Signature: 



CLARITY ON DECLARATION OF INTEREST SBD 4 (a)

BIDDER NAME	
LEGISLATION ON DISCLOSURE OF INTEREST	
<p>The Public Service Act 103 of 1994 indicates in section 30(1) that "No employee shall perform or engage himself or herself to perform remunerative work outside his or her employment in the relevant department, except with the written permission of the executive authority of the department."</p> <p>Furthermore, in terms of the Public Service Regulations paragraph 13(c), "An employee shall not conduct business with any organ of state or be a director of a public or private company conducting business with an organ of state, unless such employee is in an official capacity a director of a company listed in schedule 2 and 3 of the Public Finance Management Act"</p> <p>Treasury Regulations 16A8.4 further indicates that "If a supply chain management official or other role player, or any close family member, partner or associate of such official or other role player, has any private or business interest in any contract to be awarded, that official or other role player must-(a) disclose that interest; and (b) withdraw from participating in any manner whatsoever in the process relating to that contract."</p>	
CLARITY ON HOW TO DISCLOSE	
<p>Clause 2.2 of the Bidders Disclosure (SBD4), require the bidder to disclose a relationship with any person employed by the entire KZN Department of Health, even if that person is not employed by the procuring institution. The Department may use other Computer Assisted Techniques to verify possible interest, should you be found to have failed to disclose correctly, your bid/quotation will be treated as a false declaration, treated as non-responsive and disqualified.</p> <p>For example, if the tender is advertised or invited by Addington Hospital, yet the person with interest is employed by Manguzi Hospital, as long as that official is employed by the Department of Health, the bidder is required to disclose interest. Therefore the question is, do you, or any person connected with the bidder, have a relationship with any person who is employed by the KZN Department of Health? If so, please furnish particulars on Bidders Disclosure (SBD4) section 2.2.1, as attached below,</p>	

I read the above clarity on disclosure of interest and I commit to disclose as directed, should I fail to disclose correctly, I am aware of the consequences, which may include disqualification of my offer.

BIDDER SURNAME AND INITIALS

SIGNATURE

DATE

GENERAL CONDITIONS OF CONTRACT

NOTES

The purpose of this document is to:

- (i) Draw special attention to certain general conditions applicable to government bids, contracts and orders; and
- (ii) To ensure that clients be familiar with regard to the rights and obligations of all parties involved in doing business with government.

In this document words in the singular also mean in the plural and vice versa and words in the masculine also mean in the feminine and neuter.

- The General Conditions of Contract will form part of all bid/quotation documents and may not be amended.
- Special Conditions of Contract (SCC) relevant to a specific bid, should be compiled separately for every bid (if applicable) and will supplement the General Conditions of Contract. Whenever there is a conflict, the provisions in the SCC shall prevail.

1. Definitions

The following terms shall be interpreted as indicated:

- 1.1. "Closing time" means the date and hour specified in the bidding documents for the receipt of bids.
- 1.2. "Contract" means the written agreement entered into between the purchaser and the supplier, as recorded in the contract form signed by the parties, including all attachments and appendices thereto and all documents incorporated by reference therein.
- 1.3. "Contract price" means the price payable to the supplier under the contract for the full and proper performance of his contractual obligations.
- 1.4. "Corrupt practice" means the offering, giving, receiving, or soliciting of any thing of value to influence the action of a public official in the procurement process or in contract execution.
- 1.5. "Countervailing duties" are imposed in cases where an enterprise abroad is subsidized by its government and encouraged to market its products internationally.
- 1.6. "Country of origin" means the place where the goods were mined, grown or produced or from which the services are supplied. Goods are produced when, through manufacturing, processing or substantial and major assembly of components, a commercially recognized new product results that is substantially different in basic characteristics or in purpose or utility from its components.
- 1.7. "Day" means calendar day.
- 1.8. "Delivery" means delivery in compliance of the conditions of the contract or order.
- 1.9. "Delivery ex stock" means immediate delivery directly from stock actually on hand.
- 1.10. "Delivery into consignees store or to his site" means delivered and unloaded in the specified store or depot or on the specified site in compliance with the conditions of the contract or order, the supplier bearing all risks and charges involved until the supplies are so delivered and a valid receipt is obtained.
- 1.11. "Dumping" occurs when a private enterprise abroad market its goods on own initiative in the RSA at lower prices than that of the country of origin and which have the potential to harm the local industries in the RSA
- 1.12. "Force majeure" means an event beyond the control of the supplier and not involving the supplier's fault or negligence and not foreseeable. Such events may include, but is not restricted to, acts of the purchaser in its sovereign capacity, wars or revolutions, fires, floods, epidemics, quarantine restrictions and freight embargoes.
- 1.13. "Fraudulent practice" means a misrepresentation of facts in order to influence a procurement process or the execution of a contract to the detriment of any bidder, and includes collusive practice among bidders (prior to or after bid submission) designed to establish bid prices at artificial non-competitive levels and to deprive the bidder of the benefits of free and open competition.
- 1.14. "GCC" means the General Conditions of Contract.
- 1.15. "Goods" means all of the equipment, machinery, and/or other materials that the supplier is required to supply to the purchaser under the contract.
- 1.16. "Imported content" means that portion of the bidding price represented by the cost of components, parts or materials which have been or are still to be imported (whether by the supplier or his subcontractors) and which costs are inclusive of the costs abroad, plus freight and other direct importation costs such as landing costs, dock dues, import duty, sales duty or other similar tax or duty at the South African place of entry as well as transportation and handling charges to the factory in the Republic where the supplies covered by the bid will be manufactured.
- 1.17. "Local content" means that portion of the bidding price which is not included in the imported content provided that local manufacture does take place.
- 1.18. "Manufacture" means the production of products in a factory using labour, materials, components and machinery and includes other related value-adding activities.
- 1.19. "Order" means an official written order issued for the supply of goods or works or the rendering of a service.
- 1.20. "Project site," where applicable, means the place indicated in bidding documents.
- 1.21. "Purchaser" means the organization purchasing the goods.
- 1.22. "Republic" means the Republic of South Africa.
- 1.23. "SCC" means the Special Conditions of Contract.
- 1.24. "Services" means those functional services ancillary to the supply of the goods, such as transportation and any other incidental services, such as installation, commissioning, provision of technical assistance, training, catering, gardening, security, maintenance and other such obligations of the supplier covered under the contract.
- 1.25. "Written" or "in writing" means handwritten in ink or any form of electronic or mechanical writing.

2. Application

- 2.1. These general conditions are applicable to all bids, contracts and orders including bids for functional and professional services, sales, hiring, letting and the granting or acquiring of rights, but excluding immovable property, unless otherwise indicated in the bidding documents.
- 2.2. Where applicable, special conditions of contract are also laid down to cover specific supplies, services or works.
- 2.3. Where such special conditions of contract are in conflict with these general conditions, the special conditions shall apply.

3. General

- 3.1. Unless otherwise indicated in the bidding documents, the purchaser shall not be liable for any expense incurred in the preparation and submission of a bid. Where applicable a non-refundable fee for documents may be charged.
- 3.2. With certain exceptions, invitations to bid are only published in the Government Tender Bulletin. The Government Tender Bulletin may be obtained directly from the Government Printer, Private Bag X85, Pretoria 0001, or accessed electronically from www.treasury.gov.za

4. Standards

- 4.1. The goods supplied shall conform to the standards mentioned in the bidding documents and specifications.

5. Use of contract documents and information; inspection.

- 5.1. The supplier shall not, without the purchaser's prior written consent, disclose the contract, or any provision thereof, or any specification, plan, drawing, pattern, sample, or information furnished by or on behalf of the purchaser in connection therewith, to any person other than a person employed by the supplier in the performance of the contract. Disclosure to any such employed person shall be made in confidence and shall extend only so far as may be necessary for purposes of such performance.
- 5.2. The supplier shall not, without the purchaser's prior written consent, make use of any document or information mentioned in GCC clause 5.1 except for purposes of performing the contract.
- 5.3. Any document, other than the contract itself mentioned in GCC clause 5.1 shall remain the property of the purchaser and shall be returned (all copies) to the purchaser on completion of the supplier's performance under the contract if so required by the purchaser.
- 5.4. The supplier shall permit the purchaser to inspect the supplier's records relating to the performance of the supplier and to have them audited by auditors appointed by the purchaser, if so required by the purchaser.

6. Patent rights

- 6.1. The supplier shall indemnify the purchaser against all third-party claims of infringement of patent, trademark, or industrial design rights arising from use of the goods or any part thereof by the purchaser.

7. Performance security

- 7.1. Within thirty (30) days of receipt of the notification of contract award, the successful bidder shall furnish to the purchaser the performance security of the amount specified in SCC.
- 7.2. The proceeds of the performance security shall be payable to the purchaser as compensation for any loss resulting from the supplier's failure to complete his obligations under the contract.
- 7.3. The performance security shall be denominated in the currency of the contract, or in a freely convertible currency acceptable to the purchaser and shall be in one of the following forms:
- (a) a bank guarantee or an irrevocable letter of credit issued by a reputable bank located in the purchaser's country or abroad, acceptable to the purchaser, in the form provided in the bidding documents or another form acceptable to the purchaser; or
- (b) a cashier's or certified cheque
- 7.4. The performance security will be discharged by the purchaser and returned to the supplier not later than thirty (30) days following the date of completion of the supplier's performance obligations under the contract, including any warranty obligations, unless otherwise specified in SCC.

8. Inspections, tests and analyses

- 8.1. All pre-bidding testing will be for the account of the bidder.
- 8.2. If it is a bid condition that supplies to be produced or services to be rendered should at any stage during production or execution or on completion be subject to inspection, the premises of the bidder or contractor shall be open, at all reasonable hours, for inspection by a representative of the Department or an organization acting on behalf of the Department.
- 8.3. If there are no inspection requirements indicated in the bidding documents and no mention is made in the contract, but during the contract period it is decided that inspections shall be carried out, the purchaser shall itself make the necessary arrangements, including payment arrangements with the testing authority concerned.
- 8.4. If the inspections, tests and analyses referred to in clauses 8.2 and 8.3 show the supplies to be in accordance with the contract requirements, the cost of the inspections, tests and analyses shall be defrayed by the purchaser.
- 8.5. Where the supplies or services referred to in clauses 8.2 and 8.3 do not comply with the contract requirements, irrespective of whether such supplies or services are accepted or not, the cost in connection with these inspections, tests or analyses shall be defrayed by the supplier.
- 8.6. Supplies and services which are referred to in clauses 8.2 and 8.3 and which do not comply with the contract requirements may be rejected.
- 8.7. Any contract supplies may on or after delivery be inspected, tested or analyzed and may be rejected if found not to comply with the requirements of the contract. Such rejected supplies shall be held at the cost and risk of the supplier who shall, when called upon, remove them immediately at his own cost and forthwith substitute them with supplies which do comply with the requirements of the contract. Failing such removal the rejected supplies shall be returned at the suppliers cost and risk. Should the supplier fail to provide the substitute supplies forthwith, the purchaser may, without giving the supplier further opportunity to substitute the rejected supplies, purchase such supplies as may be necessary at the expense of the supplier.
- 8.8. The provisions of clauses 8.4 to 8.7 shall not prejudice the right of the purchaser to cancel the contract on account of a breach of the conditions thereof, or to act in terms of Clause 23 of GCC.

9. Packing

- 9.1. The supplier shall provide such packing of the goods as is required to prevent their damage or deterioration during transit to their final destination, as indicated in the contract. The packing shall be sufficient to withstand, without limitation, rough handling during transit and exposure to extreme temperatures, salt and precipitation during transit, and open storage. Packing, case size and weights shall take into consideration, where appropriate, the remoteness of the goods' final destination and the absence of heavy handling facilities at all points in transit.
- 9.2. The packing, marking, and documentation within and outside the packages shall comply strictly with such special requirements as shall be expressly provided for in the contract, including additional requirements, if any, specified in SCC, and in any subsequent instructions ordered by the purchaser.

10. Delivery and documents

- 10.1. Delivery of the goods shall be made by the supplier in accordance with the terms specified in the contract. The details of shipping and/or other documents to be furnished by the supplier are specified in SCC.
- 10.2. Documents to be submitted by the supplier are specified in SCC.

11. Insurance

- 11.1. The goods supplied under the contract shall be fully insured in a freely convertible currency against loss or damage incidental to manufacture or acquisition, transportation, storage and delivery in the manner specified in the SCC.

12. Transportation

12.1. Should a price other than an all-inclusive delivered price be required, this shall be specified in the SCC.

13. Incidental services

13.1. The supplier may be required to provide any or all of the following services, including additional services, if any, specified in SCC:

- (a) performance or supervision of on-site assembly and/or commissioning of the supplied goods;
- (b) furnishing of tools required for assembly and/or maintenance of the supplied goods;
- (c) furnishing of a detailed operations and maintenance manual for each appropriate unit of the supplied goods;
- (d) performance or supervision or maintenance and/or repair of the supplied goods, for a period of time agreed by the parties, provided that this service shall not relieve the supplier of any warranty obligations under this contract; and
- (e) training of the purchaser's personnel, at the supplier's plant and/or on-site, in assembly, start-up, operation, maintenance, and/or repair of the

13.2. Prices charged by the supplier for incidental services, if not included in the contract price for the goods, shall be agreed upon in advance by the parties and shall not exceed the prevailing rates charged to other parties by the supplier for similar services.

14. Spare parts

As specified in SCC, the supplier may be required to provide any or all of the following materials, notifications, and information pertaining to spare parts manufactured or distributed by the supplier:

14.1. manufactured or distributed by the supplier:

- (a) such spare parts as the purchaser may elect to purchase from the supplier, provided that this election shall not relieve the supplier of any warranty obligations under the contract; and
- (b) in the event of termination of production of the spare parts:
 - (i) Advance notification to the purchaser of the pending termination, in sufficient time to permit the purchaser to procure needed requirements; and
 - (ii) following such termination, furnishing at no cost to the purchaser, the blueprints, drawings, and specifications of the spare parts, if requested.

15. Warranty

15.1. The supplier warrants that the goods supplied under the contract are new, unused, of the most recent or current models, and that they incorporate all recent improvements in design and materials unless provided otherwise in the contract. The supplier further warrants that all goods supplied under this contract shall have no defect, arising from design, materials, or workmanship (except when the design and/or material is required by the purchaser's specifications) or from any act or omission of the supplier, that may develop under normal use of the supplied goods in the conditions prevailing in the country of final destination.

15.2. This warranty shall remain valid for twelve (12) months after the goods, or any portion thereof as the case may be, have been delivered to and accepted at the final destination indicated in the contract, or for eighteen (18) months after the date of shipment from the port or place of loading in the source country, whichever period concludes earlier, unless specified otherwise in SCC.

15.3. The purchaser shall promptly notify the supplier in writing of any claims arising under this warranty.

15.4. Upon receipt of such notice, the supplier shall, within the period specified in SCC and with all reasonable speed, repair or replace the defective goods or parts thereof, without costs to the purchaser.

15.5. If the supplier, having been notified, fails to remedy the defect(s) within the period specified in SCC, the purchaser may proceed to take such remedial action as may be necessary, at the supplier's risk and expense and without prejudice to any other rights which the purchaser may have against the supplier under the contract.

16. Payment

16.1. The method and conditions of payment to be made to the supplier under this contract shall be specified in SCC.

16.2. The supplier shall furnish the purchaser with an invoice accompanied by a copy of the delivery note and upon fulfillment of other obligations stipulated in the contract.

16.3. Payments shall be made promptly by the purchaser, but in no case later than thirty (30) days after submission of an invoice or claim by the supplier.

16.4. Payment will be made in Rand unless otherwise stipulated in SCC.

17. Prices

17.1. Prices charged by the supplier for goods delivered and services performed under the contract shall not vary from the prices quoted by the supplier in his bid, with the exception of any price adjustments authorized in SCC or in the purchaser's request for bid validity extension, as the case may be.

18. Contract amendments

18.1. No variation in or modification of the terms of the contract shall be made except by written amendment signed by the parties concerned.

19. Assignment

19.1. The supplier shall not assign, in whole or in part, its obligations to perform under the contract, except with the purchaser's prior written consent.

20. Subcontracts

20.1. The supplier shall notify the purchaser in writing of all subcontracts awarded under this contract if not already specified in the bid. Such notification, in the original bid or later, shall not relieve the supplier from any liability or obligation under the contract.

21. Delays in the supplier's performance

21.1. Delivery of the goods and performance of services shall be made by the supplier in accordance with the time schedule prescribed by the purchaser in the contract.

21.2. If at any time during performance of the contract, the supplier or its subcontractor(s) should encounter conditions impeding timely delivery of the goods and performance of services, the supplier shall promptly notify the purchaser in writing of the fact of the delay, its likely duration and its cause(s). As soon as practicable after receipt of the supplier's notice, the purchaser shall evaluate the situation and may at his discretion extend the supplier's time for performance, with or without the imposition of penalties, in which case the extension shall be ratified by the parties by amendment of contract.

21.3. No provision in a contract shall be deemed to prohibit the obtaining of supplies or services from a national department, provincial department, or a local authority.

21.4. The right is reserved to procure outside of the contract small quantities or to have minor essential services executed if an emergency arises, the supplier's point of supply is not situated at or near the place where the supplies are required, or the supplier's services are not readily available.

- 21.5. Except as provided under GCC Clause 25, a delay by the supplier in the performance of its delivery obligations shall render the supplier liable to the imposition of penalties, pursuant to GCC Clause 22, unless an extension of time is agreed upon pursuant to GCC Clause 21.2 without the application of penalties.
- 21.6. Upon any delay beyond the delivery period in the case of a supplies contract, the purchaser shall, without canceling the contract, be entitled to purchase supplies of a similar quality and up to the same quantity in substitution of the goods not supplied in conformity with the contract and to return any goods delivered later at the supplier's expense and risk, or to cancel the contract and buy such goods as may be required to complete the contract and without prejudice to his other rights, be entitled to claim damages from the supplier.
- 22. Penalties**
- 22.1. Subject to GCC Clause 25, if the supplier fails to deliver any or all of the goods or to perform the services within the period(s) specified in the contract, the purchaser shall, without prejudice to its other remedies under the contract, deduct from the contract price, as a penalty, a sum calculated on the delivered price of the delayed goods or unperformed services using the current prime interest rate calculated for each day of the delay until actual delivery or performance. The purchaser may also consider termination of the contract pursuant to GCC Clause 23.
- 23. Termination for default**
- 23.1. The purchaser, without prejudice to any other remedy for breach of contract, by written notice of default sent to the supplier, may terminate this contract in whole or in part:
- (a) if the supplier fails to deliver any or all of the goods within the period(s) specified in the contract, or within any extension thereof granted by the purchaser pursuant to GCC Clause 21.2;
 - (b) if the Supplier fails to perform any other obligation(s) under the contract; or
 - (c) if the supplier, in the judgment of the purchaser, has engaged in corrupt or fraudulent practices in competing for or in executing the contract.
- 23.2. In the event the purchaser terminates the contract in whole or in part, the purchaser may procure, upon such terms and in such manner as it deems appropriate, goods, works or services similar to those undelivered, and the supplier shall be liable to the purchaser for any excess costs for such similar goods, works or services. However, the supplier shall continue performance of the contract to the extent not terminated.
- 23.3. Where the purchaser terminates the contract in whole or in part, the purchaser may decide to impose a restriction penalty on the supplier by prohibiting such supplier from doing business with the public sector for a period not exceeding 10 years.
- 23.4. If a purchaser intends imposing a restriction on a supplier or any person associated with the supplier, the supplier will be allowed a time period of not more than fourteen (14) days to provide reasons why the envisaged restriction should not be imposed. Should the supplier fail to respond within the stipulated fourteen (14) days the purchaser may regard the intended penalty as not objected against and may impose it on the supplier.
- 23.5. Any restriction imposed on any person by the Accounting Officer / Authority will, at the discretion of the Accounting Officer / Authority, also be applicable to any other enterprise or any partner, manager, director or other person who wholly or partly exercises or exercised or may exercise control over the enterprise of the first-mentioned person, and with which enterprise or person the first-mentioned person, is or was in the opinion of the Accounting Officer / Authority actively associated.
- 23.6. If a restriction is imposed, the purchaser must, within five (5) working days of such imposition, furnish the National Treasury, with the following information:
- (i) the name and address of the supplier and / or person restricted by the purchaser;
 - (ii) the date of commencement of the restriction
 - (iii) the period of restriction; and
 - (iv) the reasons for the restriction.
- These details will be loaded in the National Treasury's central database of suppliers or persons prohibited from doing business with the public sector.
- 23.7. If a court of law convicts a person of an offence as contemplated in sections 12 or 13 of the Prevention and Combating of Corrupt Activities Act, No. 12 of 2004, the court may also rule that such person's name be endorsed on the Register for Tender Defaulters. When a person's name has been endorsed on the Register, the person will be prohibited from doing business with the public sector for a period not less than five years and not more than 10 years. The National Treasury is empowered to determine the period of restriction and each case will be dealt with on its own merits. According to section 32 of the Act the Register must be open to the public. The Register can be perused on the National Treasury website.
- 24. Anti-dumping and countervailing duties and rights**
- 24.1. When, after the date of bid, provisional payments are required, or antidumping or countervailing duties are imposed, or the amount of a provisional payment or anti-dumping or countervailing right is increased in respect of any dumped or subsidized import, the State is not liable for any amount so required or imposed, or for the amount of any such increase. When, after the said date, such a provisional payment is no longer required or any such anti-dumping or countervailing right is abolished, or where the amount of such provisional payment or any such right is reduced, any such favourable difference shall on demand be paid forthwith by the contractor to the State or the State may deduct such amounts from moneys (if any) which may otherwise be due to the contractor in regard to supplies or services which he delivered or rendered, or is to deliver or render in terms of the contract or any other contract or any other amount which may be due to him.
- 25. Force Majeure**
- 25.1. Notwithstanding the provisions of GCC Clauses 22 and 23, the supplier shall not be liable for forfeiture of its performance security, damages, or termination for default if and to the extent that his delay in performance or other failure to perform his obligations under the contract is the result of an event of force majeure.
- 25.2. If a force majeure situation arises, the supplier shall promptly notify the purchaser in writing of such condition and the cause thereof. Unless otherwise directed by the purchaser in writing, the supplier shall continue to perform its obligations under the contract as far as is reasonably practical, and shall seek all reasonable alternative means for performance not prevented by the force majeure event.
- 26. Termination for insolvency**
- 26.1. The purchaser may at any time terminate the contract by giving written notice to the supplier if the supplier becomes bankrupt or otherwise insolvent. In this event, termination will be without compensation to the supplier, provided that such termination will not prejudice or affect any right of action or remedy which has accrued or will accrue thereafter to the purchaser.
- 27. Settlement of Disputes**
- 27.1. If any dispute or difference of any kind whatsoever arises between the purchaser and the supplier in connection with or arising out of the contract, the parties shall make every effort to resolve amicably such dispute or difference by mutual consultation.

- 27.2. If, after thirty (30) days, the parties have failed to resolve their dispute or difference by such mutual consultation, then either the purchaser or the supplier may give notice to the other party of his intention to commence with mediation. No mediation in respect of this matter may be commenced unless such notice is given to the other party.
- 27.3. Should it not be possible to settle a dispute by means of mediation, it may be settled in a South African court of law.
- 27.4. Mediation proceedings shall be conducted in accordance with the rules of procedure specified in the SCC.
- 27.5. Notwithstanding any reference to mediation and/or court proceedings herein,
(a) the parties shall continue to perform their respective obligations under the contract unless they otherwise agree; and
(b) the purchaser shall pay the supplier any monies due the supplier.
- 28. Limitation of liability**
- 28.1. Except in cases of criminal negligence or willful misconduct, and in the case of infringement pursuant to Clause 6;
(a) the supplier shall not be liable to the purchaser, whether in contract, tort, or otherwise, for any indirect or consequential loss or damage, loss of use, loss of production, or loss of profits or interest costs, provided that this exclusion shall not apply to any obligation of the supplier to pay penalties and/or damages to the purchaser; and
(b) the aggregate liability of the supplier to the purchaser, whether under the contract, in tort or otherwise, shall not exceed the total contract price, provided that this limitation shall not apply to the cost of repairing or replacing defective equipment.
- 29. Governing language**
- 29.1. The contract shall be written in English. All correspondence and other documents pertaining to the contract that is exchanged by the parties shall also be written in English.
- 30. Applicable law**
- 30.1. The contract shall be interpreted in accordance with South African laws, unless otherwise specified in SCC.
- 31. Notices**
- 31.1. Every written acceptance of a bid shall be posted to the supplier concerned by registered or certified mail and any other notice to him shall be posted by ordinary mail to the address furnished in his bid or to the address notified later by him in writing and such posting shall be deemed to be proper service of such notice
- 31.2. The time mentioned in the contract documents for performing any act after such aforesaid notice has been given, shall be reckoned from the date of posting of such notice.
- 32. Taxes and duties**
- 32.1. A foreign supplier shall be entirely responsible for all taxes, stamp duties, license fees, and other such levies imposed outside the purchaser's country.
- 32.2. A local supplier shall be entirely responsible for all taxes, duties, license fees, etc., incurred until delivery of the contracted goods to the purchaser.
- 32.3. No contract shall be concluded with any bidder whose tax matters are not in order. Prior to the award of a bid the Department must be in possession of a tax clearance certificate, submitted by the bidder. This certificate must be an original issued by the South African Revenue Services.
- 33. National Industrial Participation (NIP) Programme**
- 33.1. The NIP Programme administered by the Department of Trade and Industry shall be applicable to all contracts that are subject to the NIP obligation.
- 34. Prohibition of Restrictive practices**
- 34.1. In terms of section 4 (1) (b) (iii) of the Competition Act No. 89 of 1998, as amended, an agreement between, or concerted practice by, firms, or a decision by an association of firms, is prohibited if it is between parties in a horizontal relationship and if a bidder (s) is / are or a contractor(s) was / were involved in collusive bidding (or bid rigging).
- 34.2. If a bidder(s) or contractor(s), based on reasonable grounds or evidence obtained by the purchaser, has / have engaged in the restrictive practice referred to above, the purchaser may refer the matter to the Competition Commission for investigation and possible imposition of administrative penalties as contemplated in the Competition Act No. 89 of 1998.
- 34.3. If a bidder(s) or contractor(s), has / have been found guilty by the Competition Commission of the restrictive practice referred to above, the purchaser may, in addition and without prejudice to any other remedy provided for, invalidate the bid(s) for such item(s) offered, and / or terminate the contract in whole or part, and / or restrict the bidder(s) or contractor(s) from conducting business with the public sector for a period not exceeding ten (10) years and / or claim damages from the bidder(s) or contractor(s) concerned.

SPECIAL CONDITIONS OF CONTRACT

1. AMENDMENT OF CONTRACT

- 1.1. Any amendment to or renunciation of the provisions of the contract shall at all times be done in writing and shall be signed by both parties.

2. CHANGE OF ADDRESS

- 2.1. Bidders must advise the Department of Health (institution where the offer was submitted) should their address (domicilium citandi et executandi) details change from the time of bidding to the expiry of the contract.

3. GENERAL CONDITIONS ATTACHED TO THIS QUOTATION

- 3.1. The Department is under no obligation to accept the lowest or any quote.
- 3.2. The Department reserves the right to communicate in writing with vendors in cases where information is incomplete or where there are obscurities regarding technical aspects of the offer, to obtain confirmation of prices or preference claims in cases where it is evident that a typing, written, transfer or unit error has been made, to investigate the vendor's standing and ability to complete the supply/service satisfactorily.
- 3.3. **ALL DECISIONS TAKEN BY THE DEPARTMENT ARE FINAL, INCLUDING THE AWARD OR CANCELLATION OF THIS QUOTATION.**
- 3.4. The price quoted must include VAT (if VAT vendor).
- 3.5. Should a bidder become a VAT vendor after award or during the implementation of a contract, they may not request the VAT percentage from the Department as the service provider made an offer during the period they were not registered as a VAT vendor. The Department is only liable for any VAT from registered VAT vendors as originally stated on the quotation document.
- 3.6. The bidder must ensure the correctness & validity of the quotation:
- (i) that the price(s), rate(s) & preference quoted cover all for the work/item (s) & accept that any mistakes regarding the price (s) & calculations will be at the bidder's risk;
- (ii) it is the responsibility of the bidder to confirm receipt of their quotation and to keep proof thereof.
- 3.7. The bidder must accept full responsibility for the proper execution & fulfilment of all obligations conditions devolving on under this agreement, as the Principal (s) liable for the due fulfilment of this contract.
- 3.8. This quotation will be evaluated based on the preferential procurement points system, specification, correctness of information and/or functionality criteria. All required documentation must be completed in full and submitted.
- 3.9. Offers must comply strictly with the specification.
- 3.10. Only offers that meet or are greater than the specification will be considered.
- 3.11. Late offers will not be considered.
- 3.12. Expired product/s will not be accepted. All products supplied must be valid for a minimum period of six months.
- 3.13. Used/ second-hand products will not be accepted.
- 3.14. A bidder not registered on the Central Suppliers Database or whose verification has failed will not be considered.
- 3.15. All delivery costs must be included in the quoted price for delivery at the prescribed destination.
- 3.16. Only firm prices will be accepted. Such prices must remain firm for the contract period. Non-firm prices (including rates of exchange variations) will not be considered.
- 3.17. In cases where different delivery points influence the pricing, a separate pricing schedule must be submitted for each delivery point.
- 3.18. In the event of a bidder having multiple quotes, only the cheapest according to specification will be considered.
- 3.19. Verification will be conducted to identify if bidders have multiple companies and are cover-quoting for this bid.
- 3.20. In such instances, the Department reserves the right to immediately disqualify such bidders as cover-quoting is an offence that represents both corruption and acquisition fraud.
- 3.21. Should there be a variation in price and such variation is above the order amount, the Department will reserve the right to place a new order.

4. NEGOTIATIONS

- 4.1. The Department reserves the right to negotiate with the shortlisted bidder/s prior or post award. The terms and conditions for negotiations will be communicated to the shortlisted bidder/s prior to invitation to negotiations. This will be done to ensure value for money and where the bidder/s price is deemed to be exorbitant, uneconomical or not market related.

5. SPECIAL INSTRUCTIONS AND NOTICES TO BIDDERS REGARDING THE COMPLETION OF THIS QUOTATION.

- 5.1. Unless inconsistent with or expressly indicated otherwise by the context, the singular shall include the plural and vice versa and with words importing the masculine gender shall include the feminine and the neuter.
- 5.2. Under no circumstances whatsoever may the quotation/bid forms be retyped or redrafted. Photocopies of the original bid documentation may be used, but an original signature must appear on such photocopies.
- 5.3. The bidder is advised to check the number of pages and to satisfy himself that none are missing or duplicated.
- 5.4. Quotations submitted must be complete in all respects. However, where it is identified that information in a bidder's response, which does not affect the preference points or price, is incomplete in any respect, the said supplier meets all specification requirements and scores the highest points in terms of preference points and price, the Department reserves the right to request the bidder to complete/ submit such information.
- 5.5. Any alteration made by the bidder must be initialed; failure to do so may render the response invalid.
- 5.6. Use of correcting fluid is prohibited and may render the response invalid.
- 5.7. Quotations will be opened in public as soon as practicable after the closing time of quotation.
- 5.8. Where practical, prices are made public at the time of opening quotations.
- 5.9. If it is desired to make more than one offer against any individual item, such offers should be given on a photocopy of the page in question. Clear indication thereof must be stated on the schedules attached.
- 5.10. The Department is under no obligation to pay suppliers in part for work done if the supplier can no longer for fulfill their obligation.

6. SPECIAL INSTRUCTIONS REGARDING HAND DELIVERED QUOTATIONS

- 6.1. Quotation shall be lodged at the address indicated not later than the closing time specified for their receipt, and in accordance with the directives in the quotation documents.

- 14.2. In the event of delayed performance that extends beyond the delivery period, the institution is entitled to purchase commodities of a similar quantity and quality as a substitution for the outstanding commodities, without terminating the contract, as well as return commodities delivered at a later stage at the service provider's expense.
- 14.3. Alternatively, the institution may elect to terminate the contract and procure the necessary commodities in order to complete the contract. In the event that the contract is terminated the institution may claim damages from the service provider in the form of a penalty. The service provider's performance should be captured on the service provider database in order to determine whether or not the service provider should be awarded any contracts in the future.
- 14.4. If the supplier fails to deliver any or all of the goods or to perform the services within the period(s) specified in the contract, the purchaser shall, without prejudice to its other remedies under the contract, deduct from the contract price, as a penalty, a sum calculated on the delivered price of the delayed goods or unperformed services using the current prime interest rate calculated for each day of the delay until actual delivery or performance.
- 15. TERMINATION FOR DEFAULT**
- 15.1. The purchaser, without prejudice to any other remedy for breach of contract, by written notice of default sent to the supplier, may terminate this contract in whole or in part:
- (i) if the supplier fails to deliver any or all of the goods within the period(s) specified in the contract,
 - (ii) if the supplier fails to perform any other obligation(s) under the contract; or
 - (iii) if the supplier, in the judgment of the purchaser, has engaged in corrupt or fraudulent practices in competing for or in executing the contract.
- 15.2. In the event the purchaser terminates the contract in whole or in part, the purchaser may procure, upon such terms and in such manner as it deems appropriate, goods, works or services similar to those undelivered, and the supplier shall be liable to the purchaser for any excess costs for such similar goods, works or services.
- 15.3. Where the purchaser terminates the contract in whole or in part, the purchaser may decide to impose a restriction penalty on the supplier by prohibiting such supplier from doing business with the public sector for a period not exceeding 10 years.
- 16. THE DEPARTMENT RESERVES THE RIGHT TO PASS OVER ANY QUOTATION WHICH FAILS TO COMPLY WITH THE ABOVE.**

PREFERENCE POINTS CLAIM FORM IN TERMS OF THE PREFERENTIAL PROCUREMENT REGULATIONS 2022

This preference form must form part of all tenders invited. It contains general information and serves as a claim form for preference points for specific goals.

NB: BEFORE COMPLETING THIS FORM, TENDERERS MUST STUDY THE GENERAL CONDITIONS, DEFINITIONS AND DIRECTIVES APPLICABLE IN RESPECT OF THE TENDER AND PREFERENTIAL PROCUREMENT REGULATIONS, 2022

1. GENERAL CONDITIONS

- 1.1. The following preference point systems are applicable to invitations to tender:
- the 80/20 system for requirements with a Rand value of up to R50 000 000 (all applicable taxes included); and
 - the 90/10 system for requirements with a Rand value above R50 000 000 (all applicable taxes included).

1.2. The applicable preference point system for this tender is the 80/20 preference point system.

- 1.3. Points for this tender (even in the case of a tender for income-generating contracts) shall be awarded for:
- (a) Price; and
 - (b) Specific Goals.

1.4. The maximum points for this tender are allocated as follows:

	POINTS
PRICE	80
SPECIFIC GOALS	20
Total points for Price and Specific Goals	100

1.5. Failure on the part of a tenderer to submit proof or documentation required in terms of this tender to claim points for specific goals with the tender, will be interpreted to mean that preference points for specific goals are not claimed.

1.6. The organ of state reserves the right to require of a tenderer, either before a tender is adjudicated or at any time subsequently, to substantiate any claim in regard to preferences, in any manner required by the organ of state.

2. DEFINITIONS

- (a) "tender" means a written offer in the form determined by an organ of state in response to an invitation to provide goods or services through price quotations, competitive tendering process or any other method envisaged in legislation;
- (b) "price" means an amount of money tendered for goods or services, and includes all applicable taxes less all unconditional discounts;
- (c) "rand value" means the total estimated value of a contract in Rand, calculated at the time of bid invitation, and includes all applicable taxes;
- (d) "tender for income-generating contracts" means a written offer in the form determined by an organ of state in response to an invitation for the origination of income-generating contracts through any method envisaged in legislation that will result in a legal agreement between the organ of state and a third party that produces revenue for the organ of state, and includes, but is not limited to, leasing and disposal of assets and concession contracts, excluding direct sales and disposal of assets through public auctions; and
- (e) "the Act" means the Preferential Procurement Policy Framework Act, 2000 (Act No. 5 of 2000).

3. FORMULAE FOR PROCUREMENT OF GOODS AND SERVICES

3.1. POINTS AWARDED FOR PRICE

3.1.1. THE 80/20 OR 90/10 PREFERENCE POINT SYSTEMS

A maximum of 80 or 90 points is allocated for price on the following basis:

$$\begin{array}{ccc}
 \text{80/20} & & \text{90/10} \\
 \boxed{Ps = 80 \left(1 - \frac{Pt - Pmin}{Pmin} \right)} & \text{OR} & \boxed{Ps = 90 \left(1 - \frac{Pt - Pmin}{Pmin} \right)}
 \end{array}$$

Where

- Ps = Points scored for price of tender under consideration
- Pt = Price of tender under consideration
- Pmin = Price of lowest acceptable tender

3.2. FORMULAE FOR DISPOSAL OR LEASING OF STATE ASSETS AND INCOME GENERATING PROCUREMENT

3.2.1. POINTS AWARDED FOR PRICE

A maximum of 80 or 90 points is allocated for price on the following basis:

$$\begin{array}{ccc}
 \text{80/20} & & \text{90/10} \\
 \boxed{Ps = 80 \left(1 + \frac{Pt - Pmax}{Pmax} \right)} & \text{OR} & \boxed{Ps = 90 \left(1 + \frac{Pt - Pmax}{Pmax} \right)}
 \end{array}$$

Where

- Ps = Points scored for price of tender under consideration
- Pt = Price of tender under consideration
- Pmax = Price of highest acceptable tender

4. POINTS AWARDED FOR SPECIFIC GOALS

- 4.1. In terms of Regulation 4(2); 5(2); 6(2) and 7(2) of the Preferential Procurement Regulations, preference points must be awarded for specific goals stated in the tender. For the purposes of this tender the tenderer will be allocated points based on the goals stated in table 1 below as may be supported by proof/ documentation stated in the conditions of this tender:
- 4.2. In cases where organs of state intend to use Regulation 3(2) of the Regulations, which states that, if it is unclear whether the 80/20 or 90/10 preference point system applies, an organ of state must, in the tender documents, stipulate in the case of—
- (a) an invitation for tender for income-generating contracts, that either the 80/20 or 90/10 preference point system will apply and that the highest acceptable tender will be used to determine the applicable preference point system; or
 - (b) any other invitation for tender, that either the 80/20 or 90/10 preference point system will apply and that the lowest acceptable tender will be used to determine the applicable preference point system,
- then the organ of state must indicate the points allocated for specific goals for both the 90/10 and 80/20 preference point system.

Table 1: Specific goals for the tender and points claimed are indicated per the table below.
Note to tenderers: The tenderer must indicate how they claim points for each preference point system.

The specific goal/s allocated points in terms of this tender	Number of points allocated (80/20 system)	Number of points claimed (80/20 system)
RDP Goal: Full points allocated to promote South African owned enterprises	20	

DECLARATION WITH REGARD TO COMPANY/FIRM

- 4.3. Name of company/firm: _____
- 4.4. Company registration number: _____
- 4.5. TYPE OF COMPANY/ FIRM [tick applicable box]
- Partnership/Joint Venture / Consortium
 - One-person business/sole propriety
 - Close corporation
 - Public Company
 - Personal Liability Company
 - (Pty) Limited
 - Non-Profit Company
 - State Owned Company

- 4.6. I, the undersigned, who is duly authorised to do so on behalf of the company/firm, certify that the points claimed, based on the specific goals as advised in the tender, qualifies the company/ firm for the preference(s) shown and I acknowledge that:
- i) The information furnished is true and correct;
 - ii) The preference points claimed are in accordance with the General Conditions as indicated in paragraph 1 of this form;
 - iii) In the event of a contract being awarded as a result of points claimed as shown in paragraphs 1.4 and 4.2, the contractor may be required to furnish documentary proof to the satisfaction of the organ of state that the claims are correct;
 - iv) If the specific goals have been claimed or obtained on a fraudulent basis or any of the conditions of contract have not been fulfilled, the organ of state may, in addition to any other remedy it may have –
 - (a) disqualify the person from the tendering process;
 - (b) recover costs, losses or damages it has incurred or suffered as a result of that person's conduct;
 - (c) cancel the contract and claim any damages which it has suffered as a result of having to make less favourable arrangements due to such cancellation;
 - (d) recommend that the tenderer or contractor, its shareholders and directors, or only the shareholders and directors who acted on a fraudulent basis, be restricted from obtaining business from any organ of state for a period not exceeding 10 years, after the audi alleram partem (hear the other side) rule has been applied; and
 - (e) forward the matter for criminal prosecution, if deemed necessary.

_____ SIGNATURE(S) OF TENDERER(S)	
SURNAME AND NAME:	_____
DATE:	_____
ADDRESS:	_____



ANNEXURE A: SPECIFICATION FORM

NAME OF PROCURING FACILITY		HLABISA HOSPITAL	
ITEM DESCRIPTION		SUPPLY & INSTALL WASHING MACHINE AND TUMBLE DRYER (INDUSTRIAL MACHINE)	
ITEM PURPOSE		1. PATIENT CARE 2. PREVENT INFECTION	
ITEM DETAILED SPECIFICATION (INCLUDE SIZE, COLOUR, MATERIAL, ETC.)			COMPLIES (YES/NO)
1.	Specification Attached		
2.			
3.			
4.			
QUALITY STANDARD			
UNIT OF MEASURE OR PACKAGING I.E. (UNIT/BOX/ROLL/PACK/BAIL ETC)		Unit	
SAMPLE REQUIRED (YES/NO) IF YES WHEN AND HOW?		no	
ADDENDUM TO SPECIFICATION ATTACHED (YES OR NO)		Yes	

Note:

- 1.
- 2.
- 3.

SPECIFICATION APPROVED BY

Name of End-user (in full)	MAVUNDLA K.T	Name of SCM Rep (in full)	Xulu M.P
Designation / Rank (in full)	ARTISAN FOREMAN	Designation/ Rank (in full)	SCMP
Signature		Signature	
Date	13/10/2025	Date	13/10/2025

Bidder Initial here: _____



KWAZULU-NATAL PROVINCE

HEALTH
REPUBLIC OF SOUTH AFRICA

HLABISA DISTRICT HOSPITAL

Physical Address 60 Saunders Street, HLABISA 3937
Postal Address Private Bag X 5001 / HLABISA 3937
Tel: 035 838 8600 Fax: 035 838 1117 Email: Hlabisa.Maintenance@kznhealth.gov.za
www.kznhealth.gov.za/hlabisahospital.htm

MAINTENANCE SEC

Enquiries: Mr. K.T Mavundla
EXT No.: 8623
Section: Maintenance

SUPPLY AND INSTALL WASHING MACHINE X01 & TUMBLE DRYER X01 (INDUSTRIAL MACHINE)

Minimum requirement

- Service provider must have valid CIDB 1 ME contractor
- Service provider must have registered with central supplier data base.
- Service provider must attach a letter of good standing.
- Service provider must attach a proof of previous experience for this job (completion certificate)
- Service provider must attached certificate for artisan that will be on site
- Companies must have valid public liability insurance with the minimum of R3 000 000
- Service provider to report at Maintenance and complete relevant register for payment purposes.

Documents required when work is done

- The contractor shall submit the invoice with the following documents for the payment approval, if this document is not submitted we are going to take as un-finalized project.
- Signed and stamp scheduler
- Signed job cards by maintenance officer

Industrial Washer, 200G, 35KG

Best in class performance:

- 1) Industrial build, designed life of 30'000 cycles = 8 cycles per day for 10 years
- 2) 00G water extraction = 60% residual moisture after spin
- 3) Programmable display
- 4) Pocket valve saves water / energy = 45'000 liter saving per year
- 5) Internal heating for sanitization & high levels of clean-ability

Facilities required for installation, within 1 meter, per machine:

- 03 x 3/4 inch taps (01 x hot and 02 x cold)
- 01 x 40 amp 380 volt 3 phase + N + E (5 wire) supply isolator
- 01 x Ø 75 mm drain point at floor level (open box gulley recommended)
- 01 x 300 mm reinforced concrete floor with 25 MPA strength

Industrial Dryer, 37KG

Best in class performance:

- 1) Industrial build, designed life of 30'000 cycles = 8 cycles per day for 10 years
- 2) Axial airflow = energy saving = 1 kW per liter evaporation
- 3) Over-dry protection technology
- 4) Programmable display
- 5) Drum roller support = low maintenance & long bearing life
- 6) Reversing drum stops "knotting/balling" of linen & reduces drying time (save 20%)
- 7) Lint draw is easy to clean = saves time
- 8) Magnetic door lock requires no maintenance

Facilities required for installation, within 1 meter, per machine:

- 01 x 60 amp 380 volt 3 phase + N + E (5 wire) supply isolator
- 01 x Ø 200 mm ducting point

Estimated lifetime energy costs

TD6-37 paired with WS6-35@1kw per liter evaporation x 30'000 cycles=594'000 kW

Axial airflow savings @ 20% = 118'800 kW

2 of 7
k.T

WARRANTY PERIOD OF COVER

1. Whichever of the below comes first, from the date of purchase, provided that this appliance is installed, maintained and operated according to the instructions attached to or furnished with the product. Service provider will replace factory specified parts or original equipment manufacturer parts to correct manufacturing defects in materials or workmanship.

- Industrial equipment - three (3) years or nine thousand (9000) cycles or hours.

WARRANTY REQUIREMENTS

1. Proof of original purchase date or invoice number is required to obtain parts under warranty.
2. Signed and stamped Service provider installation certificate.
3. Proof of maintenance with Service provider service department, every 1500 cycles or 6 months.
4. The signed warranty page of this quote is required to activate the warranty and to confirm that the warranty terms are accepted and understood. Failure to sign will result in no warranty.

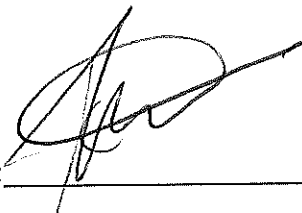
Signature:  _____

Date: 13/10/2025



Dryer featuring exceptional savings and effortless use



Priority on people

Certified ergonomic design with a human-centered approach for an outstanding user experience

- Lint filter
The horizontal filter drawer is positioned for easy access and cleaning without the need to bend down
- Large door opening for easy loading and unloading
- Easy access to vital parts from front and rear for simple servicing



Long-term savings

Innovative features to save money and time, and embrace a sustainable lifestyle with excellent water evaporation efficiency per kWh

- Moisture Balance (optional)
Helps to stop the drying process at the right time to save on energy costs



Pure control

Monitor your equipment and performance from anywhere, allowing to take action and to improve your business with OnE Laundry - the personal assistant for hygiene validation management, process management and revenue management (optional)



Outstanding productivity

- Dry more laundry in less time: a game-changing improvement
- Reversing drum
Minimizes wrinkles and drying time to get an effective and even drying performance with 2 full loads per hour



Global Advanced Hygiene

Global Advanced Hygiene program package* with proven log 6 reduction** disinfection of textiles through the laundry process, fulfilling the criteria of all local approved standards

Main options and accessories

- Connection to booking- /payment- system or coin meter
- Stainless steel drum, Stainless steel front
- Fresh air intake
- Exhaust on top (Top evacuation is not available on steam heated tumble dryers)
- Insert for drying special equipment

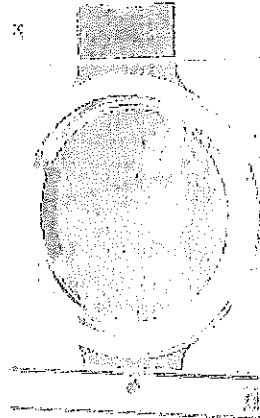

Images shown are a representation of the product only and variations may occur.

* Programs available in the standard library of all products, excluding products for specific segments where water temperature is not controllable.
 ** Log 6 reduction equals to 99,999% viral infectivity reduction. The efficacy of reduction of SARS-CoV-2 and other pathogens in the process is confirmed by RISE (The Research Institute of Sweden) on the basis of Electrolux Professional laboratory data.

Main specifications		TD6-37			
		32.0 kW	40.0 kW	Gas	Steam
Rated capacity, filling factor 1:18	kg/lb				
filling factor 1:22	kg/lb				
Drum volume	litre				
Drum diameter	mm				
Heating alternatives					
electric	kW				
gas	BTU/h (kW)				
steam at 600-700 kPa	kW				
Consumption data*					
Total time at 30.6 kg	min	28	23	23	22
Energy consumption at 30.6 kg	kWh	15.10	15.08	16.42	19.27
Evaporation	g/min	544	676	653	700
Energy kWh/litre water evaporated	kWh/l	0.98	0.98	1.07	1.26

* At rated capacity 100% cotton load at 50% initial moisture dried to 0%.

K.T

Electrical connections

Heating alternative	Main voltage		Heating power kW	Total power kW	Recommended fuse A
		Hz			
Electric heated	220-230V 3 -	50/60	19,1	20,2	63
	220-240V 3 -	50/60	19,8/23,0	20,9/24,1	63/63
	380-400V 3/3N -	50/60	19,1	20,2	35
	380-415V 3/3N -	50/60	19,8/23,0	20,6/24,1	35/50
	440V 3 -	50/60	21,0/23,0	22,2/24,1	35/35
	480V 3 -	60	22,8/23,0	23,9/24,1	35/35
Steam or Non heated	220-415V 1/3N -	50/60	-	1,3	10
	380-480V 3 -	50/60	-	1,3	10

* Total power and recommended fuse does not depend on the heating power in those cases.

Water and steam connection

Water valves	DN	20
Water pressure	kPa	200-600
Capacity at 300 kPa	l/min	60
Drain valve	ø mm	75
Draining capacity	l/min	170
Steam valve	DN	15
Steam pressure	kPa	300-600
Liquid detergent supplies		5

Floor requirements

Frequency of the dynamic force	Hz	11,2
Floor load at max extraction	kN	4,3 ± 6,9

Sound levels

Sound power/pressure level at extraction*	dB(A)	73/57
Sound power/pressure level at wash*	dB(A)	67/51

Heat emission

% of installed power, max		5
---------------------------	--	---

Shipping data**

Weight	net, kg	307
Shipping volume	m ³	1,86

Accessories

Steel base		x
Hose kits for water or steam		x
Fluff collector		x

Dimensions in mm

A	Width	910
B	Depth	1115
C	Height	1465
D1		505
D2		585
E		1675
F		1170
G		80
H		1365
I		345
J		245
K		1325
L		1245
M		280
N		105
O		210
P		160

1	Operating panel	7	Drain valve
2	Door opening ø 435 mm	8	Liquid detergent supply
3	Detergent box	9	Electrical connection
4	Cold water	10	Steam connection
5	Hot water		
6	Re-used water		

Front and side panels in silver grey and dark blue (color samples can be ordered on part number 472998313).

* Sound power levels measured according to ISO 60704.

** Average data. Crated weight/shipping volume depends on configuration. Please contact logistics for exact measures.

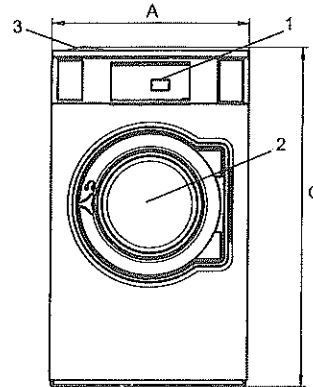

Front

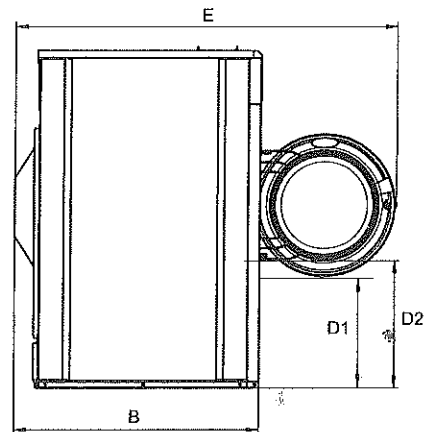

Side view

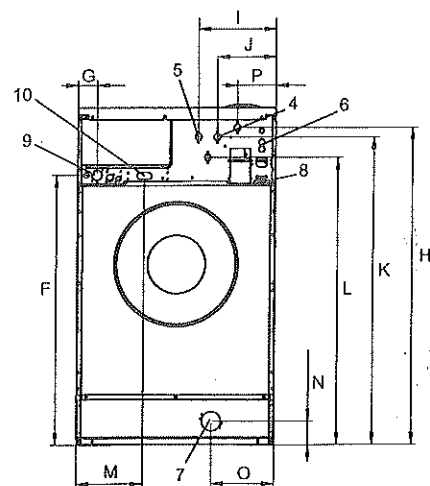

Rear



Priority on people

Certified ergonomic design with a human-centered approach for an outstanding user experience

Compass Pro* microprocessor offers:

- Easy program selection
- Language selection
- Quick selection and option buttons for the most frequently used wash programs and options
- Wash program packages optimized on Economy, Performance and Time



Long-term savings

Extremely low water and energy consumption - see table below

- Automatic Savings weighs the linen and adjusts the water level to the amount of linen, saving water and energy at less than full load
- High extraction force for efficient dewatering
- Power Balance measures, corrects the unbalance and adjusts the G force in real time, maximizing the dewatering, saving money and time in the drying process



Pure control

Monitoring of the status of the equipment and performance from anywhere, allowing to take action to improve the business

- Washers connectable to OnE Laundry, the personal assistant for hygiene validation, process management and revenue management



Global Advanced Hygiene

Global Advanced Hygiene program package* with proven log 6 reduction** disinfection of textiles through the laundry process, fulfilling the criteria of all local approved standards

Main options

- Automatic liquid detergent supply (optional I/O board)
- Savings on chemicals with help of Efficient dosing, both ED peristaltic pumps and ED Venturi
- Connection to booking- /payment- system or coin meter

* Programs available in the standard library of all products, excluding products for specific segments where water temperature is not controllable.
 ** Log 6 reduction equals to 99,9999% viral infectivity reduction. The efficacy of reduction of SARS-CoV-2 and other pathogens in the process is confirmed by RISE (The Research Institute of Sweden) on the basis of Electrolux Professional laboratory data.

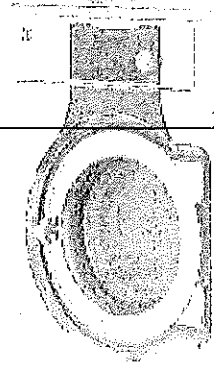

Images shown are a representation of the product only and variations may occur.

Main specifications		Consumption data "Normal 60°C"			
		EI		Steam***	
Rated capacity, filling factor 1:9	kg/lb	Full load, 35 kg	Half load, 17.5 kg	Full load, 35 kg	Half load, 17.5 kg
Drum, volume	litre	51	47	51	47
Drum, diameter	ø mm	222+57	118+30	279+0	148+0
Extraction	rpm	0.45/1.65/3.65	0.4/0.85/1.9	0.45/-	0.4/-
G-factor		-	-	7.95	4.13
Standard heating alternatives	electricity kW	58	66	58	66
	steam				
	non-heated				
Total time	min				
Water consumption (cold+hot)	litre				
Energy consumption (motor/heating/hot water)	kWh				
Steam consumption	kg				
Residual moisture	%				

* Water temperature 15°C cold water and 65°C hot water.
 ** Programs With AS.
 *** Depending on steam pressure.

k-7

Electrical connections					
Heating alternatives	Main voltage		Heating power kW	Total power kW	Recommended fuse A
	Hz	Hz			
Electric heated	220-240V 3 -	50/60	32.0/40.0	33.5/41.5	100/125
	380-415V 3N/3 -	50/60	32.0/40.0	33.5/41.5	50/63
	440V 3 -	60	32.0/40.0	33.5/41.5	50/63
	480V 3 -	60	32.0/40.0	33.5/41.5	50/63
Gas heated / Steam heated	220-240V 1/1N -	50/60	-	1.8	10
	220-480V 3/3N -	50/60	-	1.5	10

Steam, gas and air connections			
Steam	ISO 7/1-R		1"
Steam pressure		kPa	100-1000
Steam consumption		kg/h	65
Condensate	ISO 7/1-R		1"
Gas	NG/PG	ISO 7/1-R	1/2"
Gas pressure	Natural gas	Pa	2000
		mbar	20
	Propane	Pa	2800-3700
		mbar	28-37
Air outlet		ø mm	200
Maximum air flow:			
	Electric 50 Hz / 60 Hz	m³/h	1140 / 1140
	Gas 50 Hz / 60 Hz	m³/h	1140 / 1140
	Steam 50 Hz / 60 Hz	m³/h	1380 / 1380
Maximum static back pressure:			
	Electric 50 Hz / 60 Hz	Pa	270 / 800
	Gas 50 Hz / 60 Hz	Pa	410 / 800
	Steam 50 Hz / 60 Hz	Pa	900 / 1100
Sound levels			
Sound power/pressure level at drying*		dB(A)	74/57
Heat emission			
% of installed power, max			15
Shipping data**			
Shipping volume		net, kg	283
		crated, m³	3.25
Dimensions in mm			
A	Width		960
B(a)	Depth		1560
B(b)	Depth		1640
C	Height		1855
D			660
E			720
F			170
G			1490
H			200
I			180
J			1560
K			50
L			480
M			580
N			805

- 1 Control panel
- 2 Door opening ø 810 mm
- 3 Electrical connection
- 4 Gas connection
- 5 Exhaust connection
- 6 Condensate connection
- 7 Steam connection
- 8 Lint screen

* Sound power levels measured according to ISO 60704.
 ** Average data. Crated weight/shipping volume depends on configuration. Please contact logistics for exact measures.

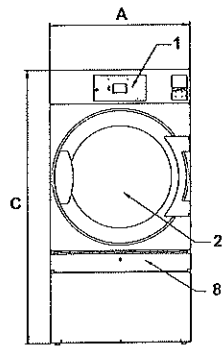

Front

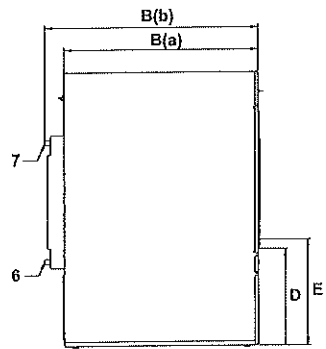

Left side

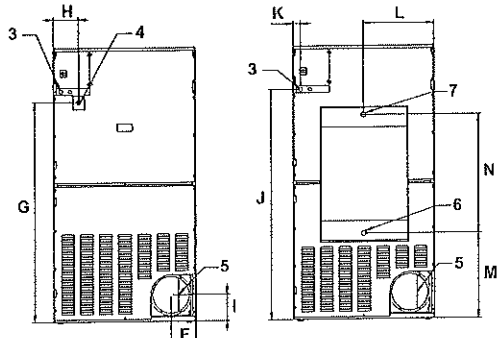

El, gas

Steam

Rear side

No. 438908656EN/20201116
 reserve the right to alter specifications without notice.



Quotation No.	HLB 153 25-26
Quotation Description	SUPPLY AND INSTALL INDUSTRIAL WASHING MACHINE AND TUMBLE DRYER

EVALUATION CRITERIA

This institution intends to evaluate valid quotations using **four (4) evaluation stages**. These are peremptory requirements, should the bidder/tenderer fail to comply with any of the stages as stated below, the quotation will be regarded as non-responsive, and will not progress to the final stage of evaluation:

Stage 1: Administrative Compliance, Compulsory and Mandatory Requirements

Stage 2: Capacity to Deliver

Stage 3: Compliance with Specification

Stage 4: Price and Preference Points System (Specific Goals)



STAGE 1: ADMINISTRATIVE, COMPULSORY COMPLIANCE AND MANDATORY REQUIREMENTS

NO.	REQUIREMENTS	INCLUDED IN THE PUBLISHED DOCUMENT?	TO BE RETURNED BY BIDDER/ TENDERER?
Administrative Compliance			
1.	PARTICULARS OF QUOTATION	YES	YES
2.	OFFICIAL PRICE PAGE FOR QUOTATIONS OVER R2 000.01	YES	YES
3.	BIDDER'S DISCLOSURE (SBD4)	YES	YES
4.	GENERAL CONDITIONS OF CONTRACT (GCC)	YES	YES
5.	SPECIAL CONDITIONS OF CONTRACT (SCC)	YES	YES
6.	PREFERENCE POINTS CLAIM FORM IN TERMS OF THE PREFERENTIAL PROCUREMENT REGULATIONS 2022 (SBD 6.1)	YES	YES
Compulsory Compliance			
7.	SUPPLIER UPDATED CIPC REGISTRATION DOCUMENTS	NO	YES
8.	A B-BBEE STATUS LEVEL VERIFICATION CERTIFICATE/ SWORN AFFIDAVIT (For EMEs& QSEs)	NO	YES
9.	CENTRAL SUPPLIER DATABASE COMPLIANCE REPORT (CSD)	NO	YES
Mandatory Requirements			
10.	<ul style="list-style-type: none">• Valid CIBD 1ME• Letter of good standing• Completion certificate for previous experience for this job• Service provider must attach artisan certificate that will be on site• Public liability insurance with the minimum of R3 000 000.00	NO	YES



STAGE 2: CAPACITY TO DELIVER

1.	The quoting supplier must attach proof of previous experience for this job. (completion certificate) Note.: Should you fail to submit any of the above returnable documents, your offer will be treated as non-responsive and will not proceed to the next stage of evaluation.
2.	As part of risk management, if there is valid proof that the bidder was previously issued with an order and thereafter failed to deliver without acceptable reasons, the bidder will be treated as a defaulter and will not progress to the next stage of evaluation.

STAGE 3: COMPLIANCE WITH SPECIFICATION

Requirement	Complies with Specification Yes /No
The bidder / Tenderer to confirm that SUPPLY AND INSTALL INDUSTRIAL WASHING MACHINE AND TUMBLE DRYER complies with attached specification document, should you fail to indicate compliance your quotation will not progress to the next stage of evaluation.	

STAGE 4: PRICE AND PREFERENCE POINTS

The value of this quotation is estimated not to exceed R 50 000 000 (inclusive of all applicable taxes), therefore the 80/20 preference point system shall be applicable. Points for this quotation will be awarded for:

CATEGORY	POINTS
PRICE	80
SPECIFIC GOALS	20
Total points for Price and must not exceed	100

The Department has identified the following specific goal:

Specific Goal	Number of Points allocated	Proof To Claim Specific Goal (Returnable Documents)
RDP Goal: Full points allocated to promote South African owned enterprise.	20	1. CIPC Certificate 2. BBBEE Certificate/Sworn Affidavit
NOTE: Should a responsive bidder fail to submit proof to claim points, as stated above this will not result in disqualification; however, the bidder will not be awarded points for specific goals.		